

REV.	ECN NO	CONTENT	DATE	ENGINEER
A0		Initial release	/	ZY

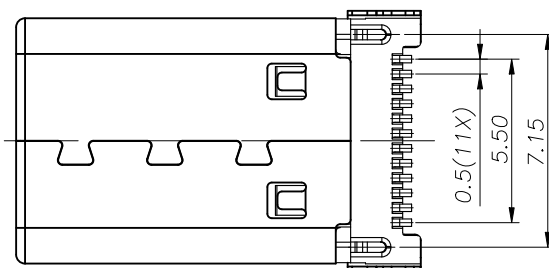

NOTE:

- MATERIAL SPECIFICATION:
 - HOUSING: HIGH TEMPERATURE RESISTANT PLASTIC, UL94 V-0.
 - CONTACTS: COPPER ALLOY
 - MID PLATE: STAINLESS STEEL
 - FRONT SHELL: STAINLESS STEEL
 - EMI PLATE: STAINLESS STEEL
- PLATING SPECIFICATION:
 - CONTACTS:
 - Ni 50u" MIN. UNDER PLATED OVER ALL.
 - Au PLATED ON THE FUNCTIONAL AREA OF CONTACT. (GOLD PLATING THICKNESS FOLLOW THE P/N)
 - FRONT SHELL:
 - Ni 30u" MIN. UNDER PLATED OVER ALL.
 - MID PLATE:
 - Ni 50u" MIN. UNDER PLATED OVER ALL.
 - EMI PLATE: CLEAR ONLY
- MECHANICAL PERFORMANCE,
 - INSERTION FORCE: 0.5~2.0kgf.
 - REMOVAL FORCE: 0.8kgf~2.0kgf.
 - DURABILITY: 10000 CYCLES.
- ELECTRICAL PERFORMANCE,
 - CURRENT RATING: 3.0A
VOLTAGE RATING: 5.0V
 - LLCR:
 - VBUS & GND PINS AND OTHER PINS: 40mA/PIN MAX.
 - SHIELD: 50mA/MAX.
 - LLCR MAX. CHANGE OF ALL PINS: 10mA.
 - INSULATION RESISTANCE: 100MΩ MIN
 - DIELECTRIC WITHSTAND VOLTAGE, AC 100V FOR 1 MINUTE.
- ENVIRONMENTAL PERFORMANCE:
 - OPERATING TEMPERATURE: -25°C~+85°C.
- IR REFLOW:
 - THE PEAK TEMPERATURE ON THE BOARD SHALL BE MAINTAINED FOR 10 SECONDS AT 260°C.

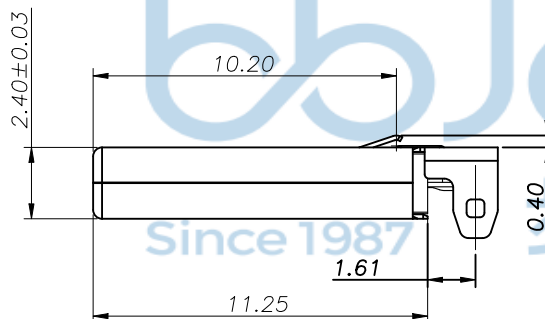
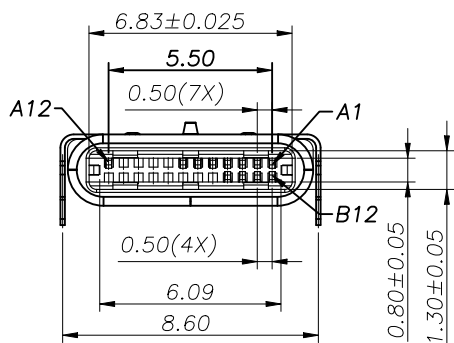
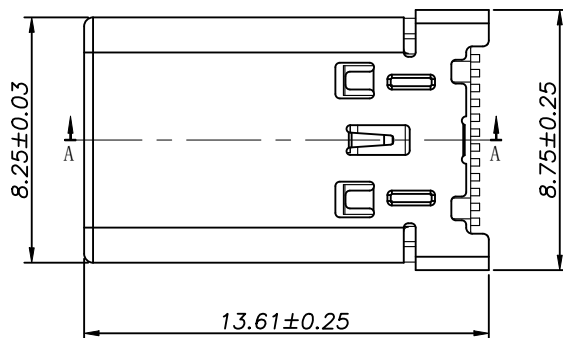
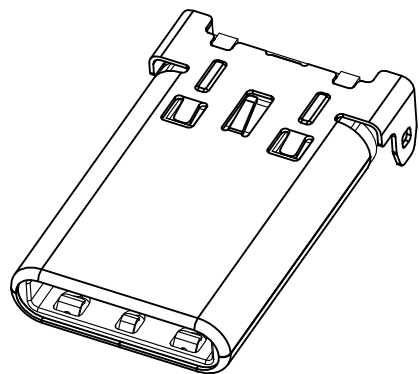

THIS DOCUMENT IS THE SOLE PROPERTY OF BBJconn Technology Co., Ltd. Corporation AND SHOULD NOT BE USED IN WHOLE OR IN PART WITHOUT PRIOR WRITTEN PERMISSION.		深圳市步步精科技有限公司 NAME: TYPE-C 12P 公头 两脚插件 L=13.60 沉板0.95 外壳带弹 端子SMT 带盖 编带 APPD. JM_Zheng CHKD. LYX DR. ZY PDWG.NO: 0338-1		X: ±0.38 XX: ±0.25 XXX: ±0.13 X': ±3' X': ±2' XX': ±1'	NAME: TYPE-C 12P 公头 两脚插件 L=13.60 沉板0.95 外壳带弹 端子SMT 带盖 编带 PJ. NO.: 126-122-120001-J8G SIZE: A4 DRW NO.: FINISH: SEE NOTES MAT'L.: SEE NOTES SCALE: N/A REV.: A0 UNIT: mm PAGE: 1/3
---	--	---	--	---	--

REV.	ECN NO	CONTENT	DATE	ENGINEER
A0		Initial release	/	ZY

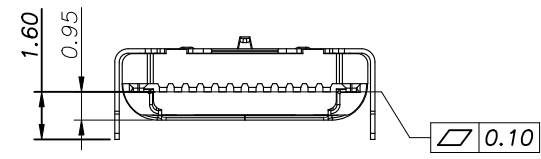
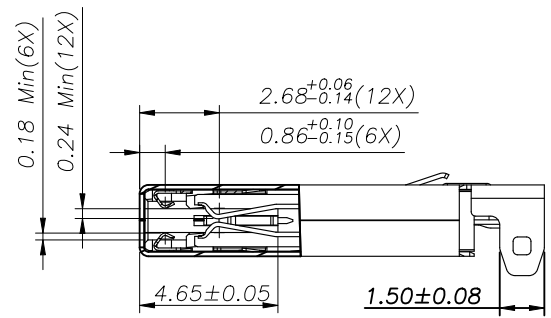

SECTION:A-A
SCALE 1:1

USB TYPE-C PIN ASSIGNMENTS

PIN NUMBER	SIGNAL NAME	PIN NUMBER	SIGNAL NAME
A1	GND	B12	GND
A2	SSTXp1	B11	SSRXp1
A3	SSTXn1	B10	SSRXn1
A4	VBus	B9	VBUS
A5	CC1	B8	
A6	Dp1	B7	
A7	Dn1	B6	
A8		B5	
A9		B4	
A10		B3	
A11		B2	
A12	GND	B1	

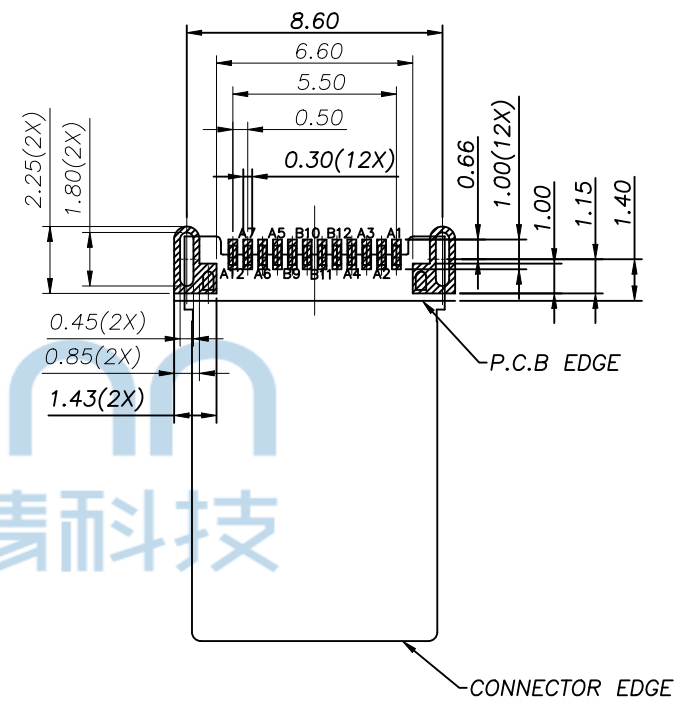

RECOMMENDED PCB LAYOUT(TOP VIEW)
TOLERANCE:±0.05



THIS DOCUMENT IS THE SOLE PROPERTY OF BBJconn Technology Co.,Ltd. Corporation AND SHOULD NOT BE USED IN WHOLE OR IN PART WITHOUT PRIOR WRITTEN PERMISSION.		深圳市步步精科技有限公司 .X: ±0.38 .X': ±3" .XX: ±0.25 .X': ±2" .XXX: ±0.13 .XX': ±1"		NAME: TYPE-C 12P 公头 两脚插件 L=13.60 沉板0.95 外壳带弹 端子SMT 带盖 编带	
APPD.	JM_Zheng		PJ. NO.: 126-122-120001-J8G		
CHKD.	LYX		SIZE: A4 DRW NO.:		
PDWG.NO:	0338-1	DR.	ZY	FINISH: SEE NOTES MAT'L.: SEE NOTES	
				SCALE: N/A	REV.: A0
				UNIT: mm	PAGE: 2/3

REV.	ECN NO	CONTENT	DATE	ENGINEER
A0		Initial release	/	ZY

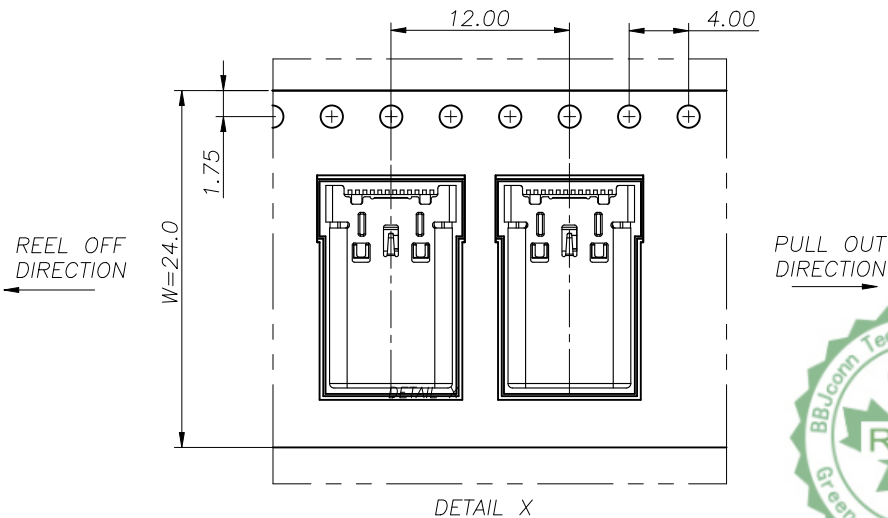
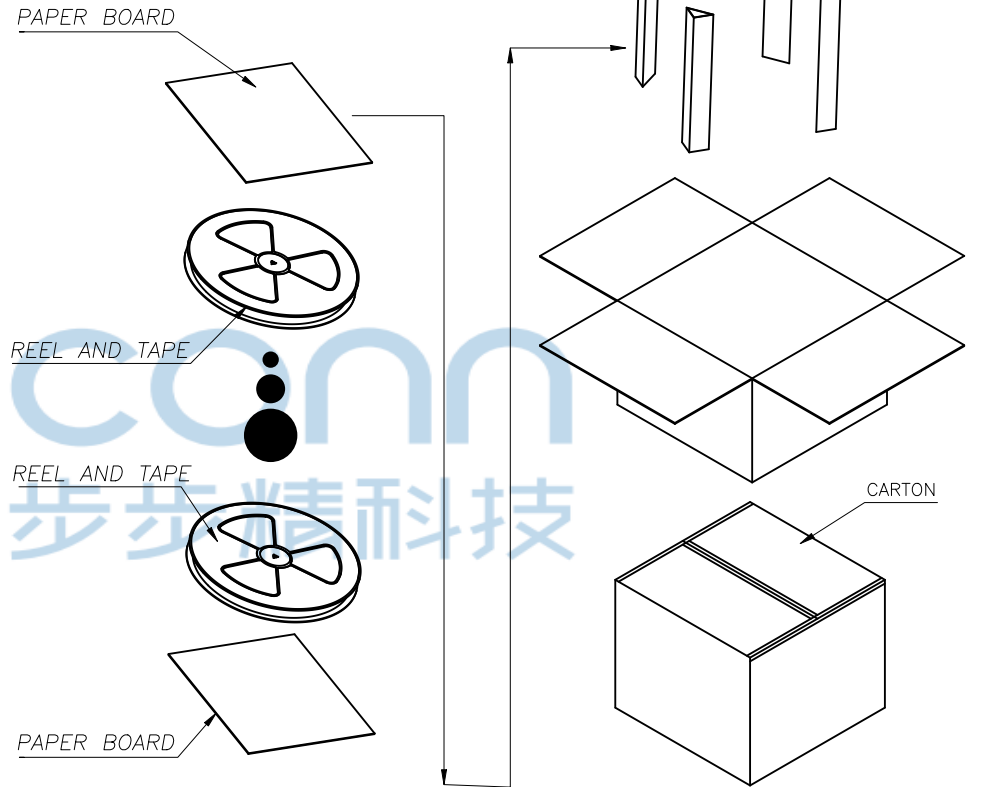
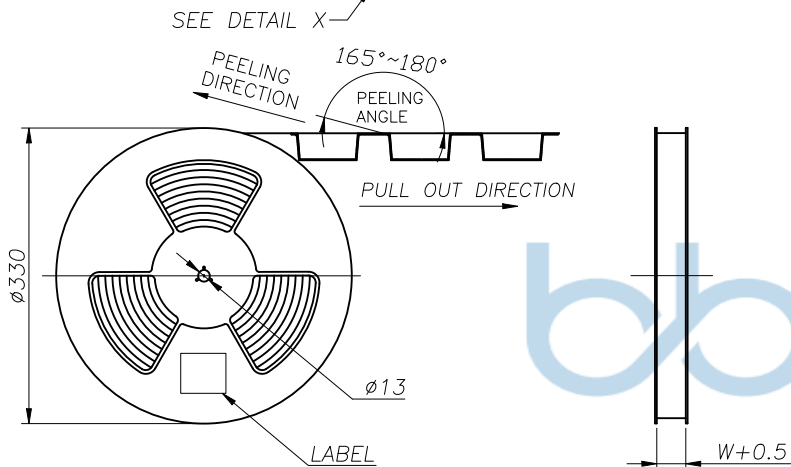
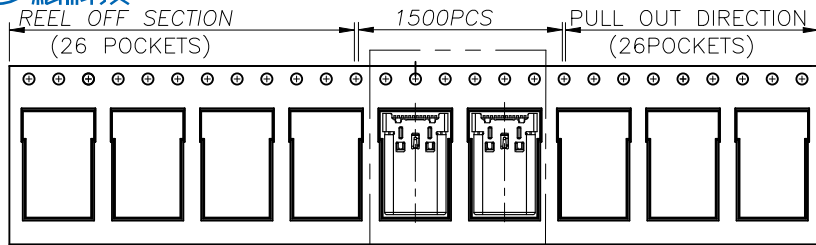

THIS DOCUMENT IS THE SOLE PROPERTY OF BBJconn Technology Co., Ltd. Corporation AND SHOULD NOT BE USED IN WHOLE OR IN PART WITHOUT PRIOR WRITTEN PERMISSION.		.X: ±0.38 .XX: ±0.25 .XXX: ±0.13		X': ±3" .X': ±2" .XX': ±1"		NAME: TYPE-C 12P 公头 两脚插件 L=13.60 沉板0.95 外壳带弹 端子SMT 带盖 编带	
APPD.	JM_Zheng	P.J. NO.: 126-122-120001-J8G		SIZE: A4 DRW NO.:			
CHKD.	LYX	FINISH: SEE NOTES		MAT'L.: SEE NOTES			
PDWG.NO:	0338-1	DR.	ZY	SCALE: N/A	REV.: A0	UNIT: mm	PAGE: 2/3

深圳市步步精科技有限公司