

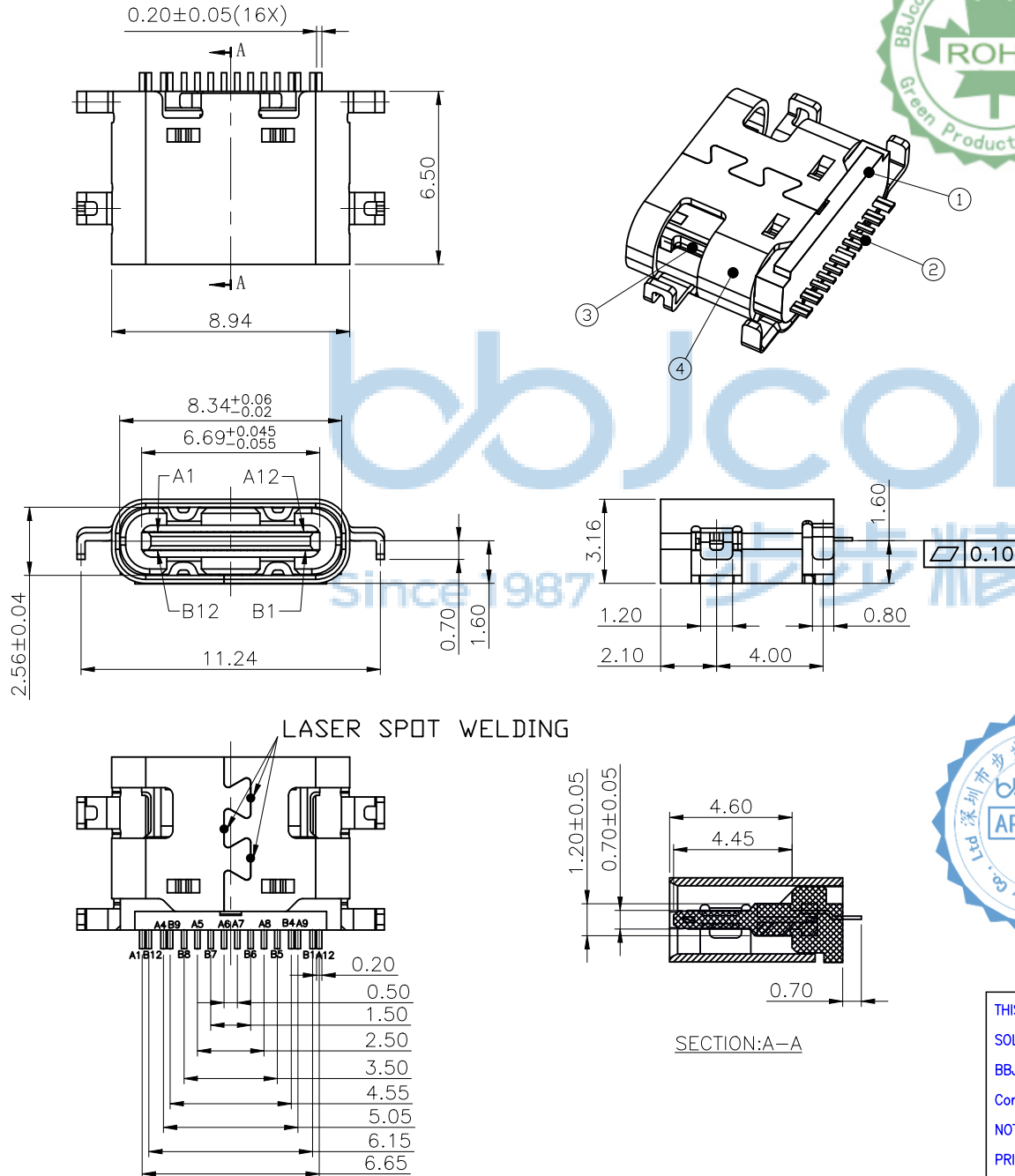

REV	ECN NO	CONTENT	DATE	ENGINEER
A0		INITIAL RELEASE	/	SGF

NOTE:

- 1.MATERIAL SPECIFICATION:**
  - 1.HOUSING:HIGH TEMPERATURE RESISTANT PLASTIC,UL94 V-0.
  - 2.CONTACTS:COPPER ALLOY
  - 3.MID PLATE: STAINLESS STEEL
  - 4.FRONT SHELL: STAINLESS STEEL
- 2.PLATING SPECIFICATION:**
  - 2-1.CONTACTS:  
Ni 50u" MIN. UNDER PLATED OVER ALL.  
Au PLATED ON THE FUNCTIONAL AREA OF CONTACT.  
(GOLD PLATING THICKNESS FOLLOW THE P/N)  
PLATING SPECIFICATIONS OF THE SOLDER AREA FOLLOW THE P/N
  - 2-2.FRONT SHELL:  
Ni 30u" MIN. UNDER PLATED OVER ALL.
  - 2-3.MID PLATE:  
CLEAR ONLY
- 3.MECHANICAL PERFORMANCE,**
  - 3-1.INSERTION FORCE: 0.5~2.0kgf.
  - 3-2.REMOVAL FORCE: 0.8kgf~2.0kgf.
  - 3-3.DURABILITY: 10000 CYCLES.
- 4.ELECTRICAL PERFORMANCE,**
  - 4-1. CURRENT RATING:3.0A  
VOLTAGE RATING:5.0V
  - 4-2. LLCR:  
VBUS & GND PINS AND OTHER PINS: 40mΩ /PIN MAX.  
SHIELD: 50mΩ/MAX.  
LLCR MAX. CHANGE OF ALL PINS: 10mΩ.
  - 4-3.INSULATION RESISTANCE: 100MΩ MIN
  - 4-4.DIELECTRIC WITHSTAND VOLTAGE,AC 100V FOR 1 MINUTE.
- 5. ENVIRONMENTAL PERFORMANCE:**  
OPERATING TEMPERATURE: -25°C~+85°C.
- 6.IR REFLOW:**  
THE PEAK TEMPERATURE ON THE BOARD SHALL BE MAINTAINED FOR 10 SECONDS AT 260°C.



THIS DOCUMENT IS THE SOLE PROPERTY OF BBJconn Technology Co.,Ltd. Corporation AND SHOULD NOT BE USED IN WHOLE PRIOR WRITTEN PERMISSION.		深圳市步步精科技有限公司 工程 部	
PDWG NO: 0338-1	DR	SGF	NAME: TYPE-C 16P 母座 四脚插 沉板1.6 带焊点 带中夹片 L=6.5 编带 PJ NO: 126-222-160002-J8G SIZE:A4 DRW NO: FINISH:SEE NOTES MAT'L:SEE NOTES SCALE:N/A REV:A0 UNIT:mm PAGE:1/3



REV	ECN NO	CONTENT	DATE	ENGINEER
A0		INITIAL RELEASE	/	SGF

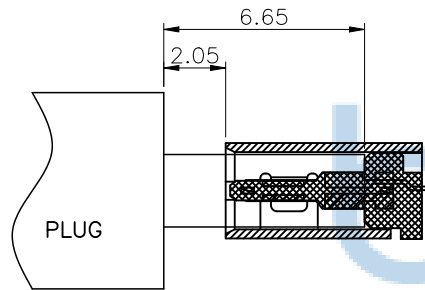

AFTER MATING

USB TYPE-C PIN ASSIGNMENTS

PIN NUMBER	SIGNAL NAME	PIN NUMBER	SIGNAL NAME
A1	GND	B12	GND
A4	VBUS	B9	VBUS
A5	CC1	B8	SBU2
A6	Dp1	B7	Dn2
A7	Dn1	B6	Dp2
A8	SBU1	B5	CC2
A9	VBUS	B4	VBUS
A12	GND	B1	GND

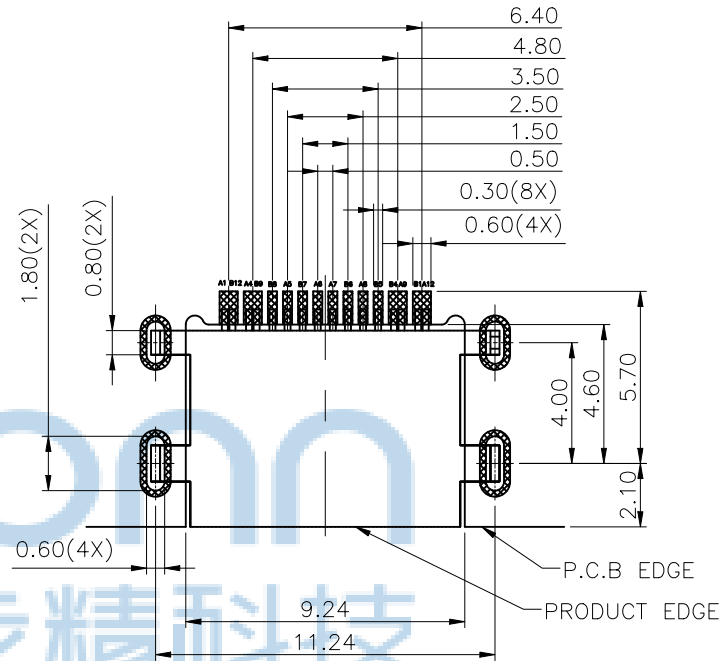

RECOMMENDED PCB LAYOUT(TOP VIEW)

THICKNESS 0.80MM;DEFAULT TOLERANCE:±0.05



THIS DOCUMENT IS THE  
SOLE PROPERTY OF  
BBJconn Technology Co.,Ltd.  
Corporation AND SHOULD  
NOT BE USED IN WHOLE  
PRIOR WRITTEN PERMISSION.

深圳市步步精科技有限公司

.X: ±0.38 X': ±3"  
.XX: ±0.25 .X': ±2"  
.XXX: ±0.13 .XX': ±1"

NAME: TYPE-C 16P 母座 四脚插 沉板1.6  
带焊点 带中夹片 L=6.5 编带

APPD JM\_Zheng

PJ NO: 126-222-160002-J8G

CHKD LYX

SIZE:A4 DRW NO:

DR SGF

FINISH:SEE NOTES MAT'L:SEE NOTES

PDWG NO: 0338-1

SCALE:N/A REV:A0 UNIT:mm PAGE:2/3

REV	ECN NO	CONTENT	DATE	ENGINEER
AO		INITIAL RELEASE	/	SGF

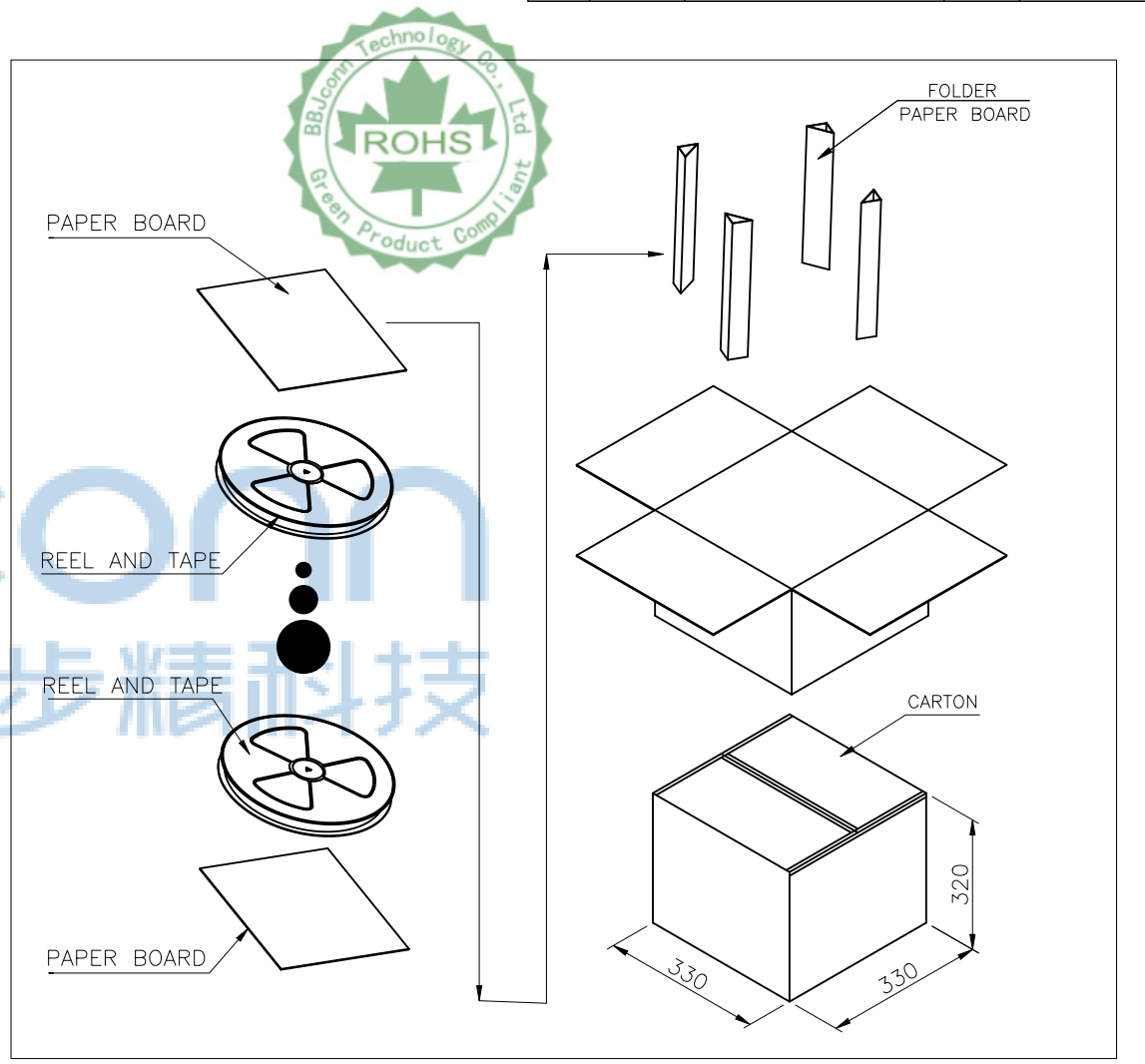
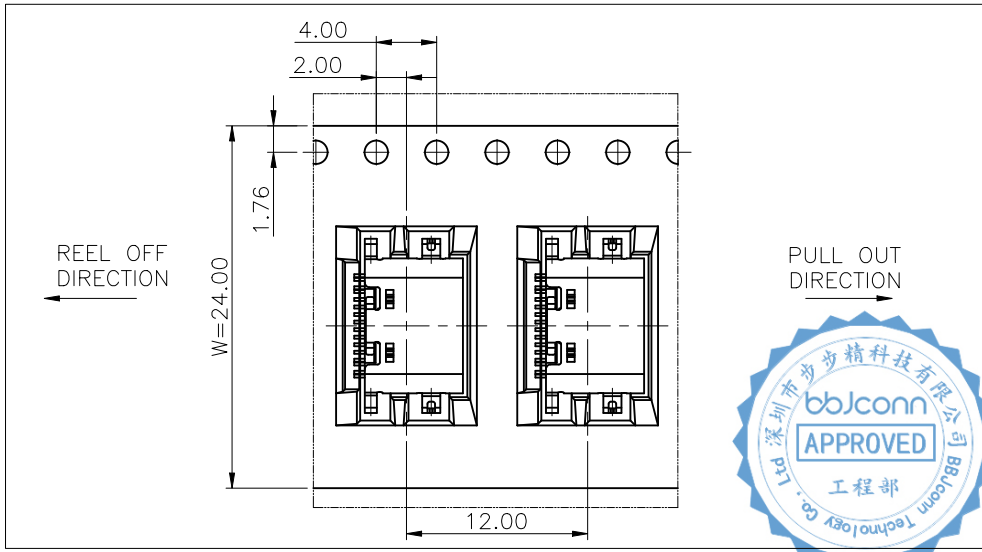
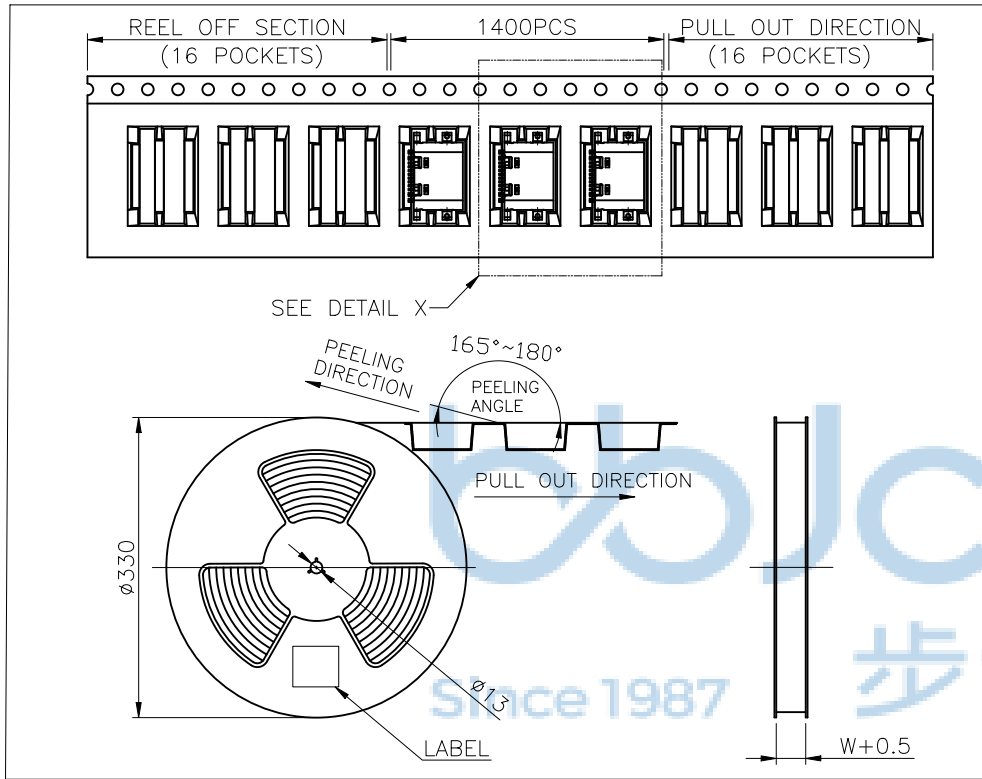

	REEL	CARTON
CONNECTOR (PCS)	1400	14000

THIS DOCUMENT IS THE SOLE PROPERTY OF BBJconn Technology Co.,Ltd. Corporation AND SHOULD NOT BE USED IN WHOLE PRIOR WRITTEN PERMISSION.

PDWG NO: 0338-1

APPD: JM\_Zheng

CHKD: LYX

DR: SGF

深圳市步步精科技有限公司

.X: ±0.38 .XX: ±0.25 .XXX: ±0.13

X': ±3' .X': ±2' .XX': ±1'

NAME: TYPE-C 16P 母座 四脚插 沉板1.6 带焊点 带中夹片 L=6.5 编带

PJ NO: 126-222-160002-J8G

SIZE:A4 DRW NO:

FINISH:SEE NOTES MAT'L:SEE NOTES

SCALE:N/A REV:AO UNIT:mm PAGE:3/3