

| REV. | ECN NO | CONTENT | DATE | ENGINEER |
|------|--------|-----------------|------|----------|
| A0 | | Initial release | / | TSP |

NOTES:

- Material:SEE TABLE1;
- Plating specification,
 - Contact:
 - Contact area: Ni50u~Min/Au;
 - Solder area: Ni50u~Min/Sn100u~Min.
 - Other area: Ni 50u~Min.
 - Shell:NI.
 - Latch:
 - Solder area: Ni50u~Min/Sn100u~Min.
 - Other area: Ni 50u~Min.
- Mechanical Performance ,
 - Insertion Force:5~20N;
 - Extraction Force:6~20N after 10000 cycles;
 - Durability:10000 cycles.
- Electrical Performance,
 - Insulation Resistance:100Ω Min.
 - Contact Resistance :50mΩ Max.
 - Dielectric Strength :100V AC.
- characteristic impedance:100 Ohm±10%;
- Marked"▼" is the important control dimentions.
- The product accords with HF STD.

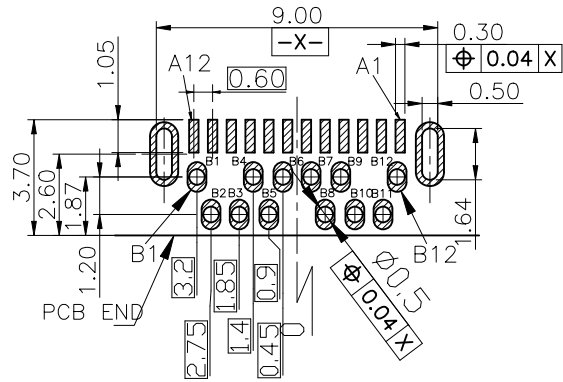
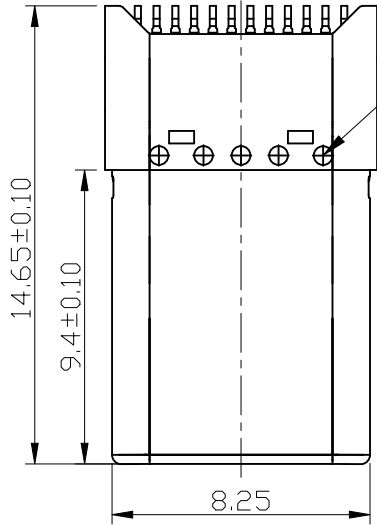

RECOMMEND P.C.B LAYOUT (THICKNESS 0.8mm)
(COMPONENT SIDE) TOLERANCE±0.03mm

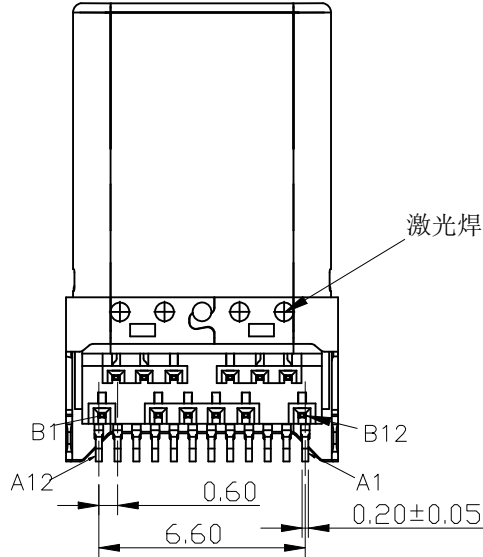
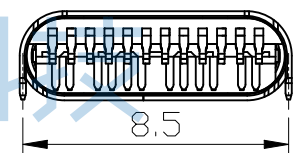
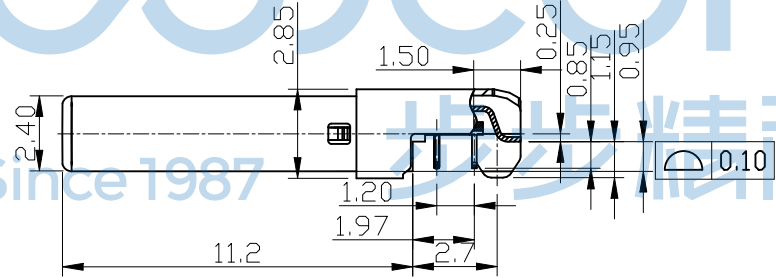
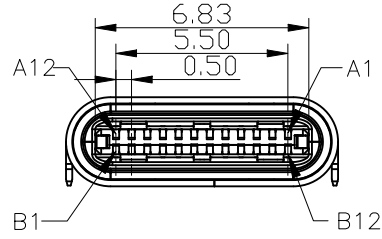

TABLE2:
PINS DESCRIPTION, ONLY USED FOR 3.1 SERIES.

| | | | | | | | | | | | |
|-----|------|------|------|-------|----|----|------|------|------|------|-----|
| A12 | A11 | A10 | A9 | A8 | A7 | A6 | A5 | A4 | A3 | A2 | A1 |
| GND | RX2+ | RX2- | VBUS | SBU1 | D- | D+ | CC | VBUS | TX1- | TX1+ | GND |
| GND | TX2+ | TX2- | VBUS | Vconn | | | SBU2 | VBUS | RX1- | RX1+ | GND |
| B1 | B2 | B3 | B4 | B5 | B6 | B7 | B8 | B9 | B10 | B11 | B12 |

TABLE1:

| | | |
|-----|------------|------------------------------------|
| 5 | EMC SPRING | Stainless Steel;SUS301, T=0.10mm; |
| 4 | CONTACT | Copper Alloy;AuNiSn; |
| 3 | LATCH | Stainless Steel;SUS301, T=0.40mm; |
| 2 | HOUSING | LCP Thermoplastic, UL94V-0; |
| 1 | SHELL | Stainless Steel;SUS316L, T=0.15mm; |
| NO. | NAME | DESCRIPTION |

THIS DOCUMENT IS THE SOLE PROPERTY OF BBJconn Technology Co.,Ltd. Corporation AND SHOULD NOT BE USED IN WHOLE OR IN PART WITHOUT PRIOR WRITTEN PERMISSION.

PDWG.NO: 0500-1 DR. TSP

深圳市步步精科技有限公司

NAME: TYPE-C 24P 公头 拉伸款 两脚插 端子SMT+DIP
沉板0.95 L=14.65 CH=0.25 编带

PJ. NO.: 126-123-240001-J8G
SIZE: A4 DRW NO.: H0019-24-F01-B

FINISH: SEE NOTES MAT'L.: SEE NOTES
SCALE: N/A REV.: A0 UNIT: mm PAGE: 1/2

| REV. | ECN NO | CONTENT | DATE | ENGINEER |
|------|--------|-----------------|------|----------|
| A0 | | Initial release | / | TSP |

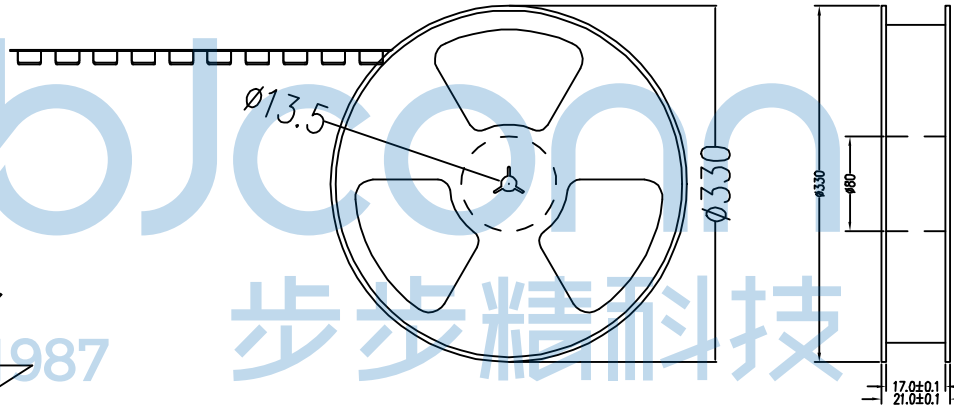
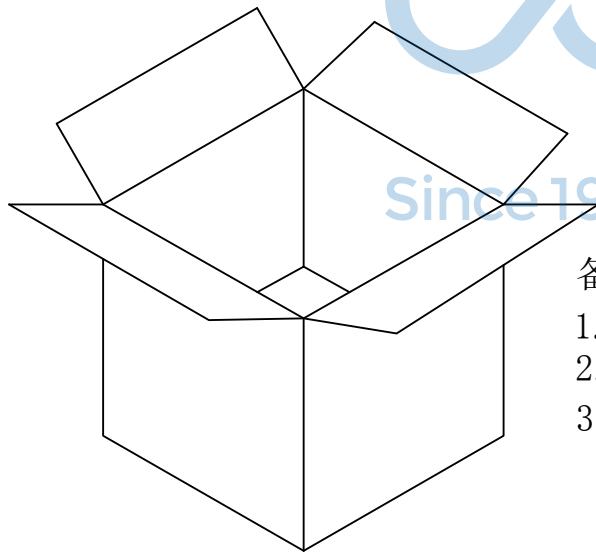
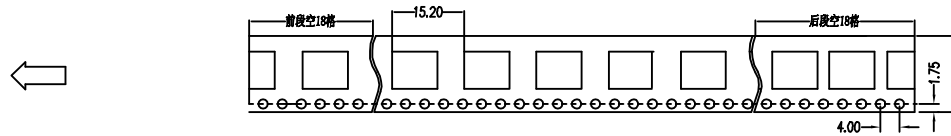
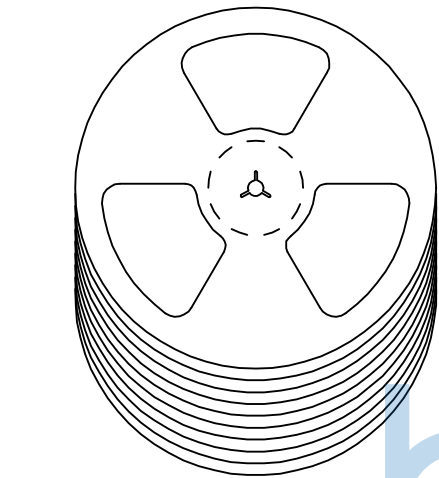

备注:

1. 包装数量: 1500/PCS/卷, 10卷/箱。
2. 包装袋长度: 每卷前后各空10-20个空格, 中间包装。
3. 材质:
载体: 聚丙烯 (PS),
上带: 聚乙烯 (PET),
卷盘: 聚苯乙烯。

纸箱规格: 345*345*23MM

纸箱规格: 345*345*35MM

| | | | |
|--|----------|--|--|
| THIS DOCUMENT IS THE SOLE PROPERTY OF BBJconn Technology Co.,Ltd. Corporation AND SHOULD NOT BE USED IN WHOLE OR IN PART WITHOUT PRIOR WRITTEN PERMISSION. | | 深圳市步步精科技有限公司 | |
| .X: ±0.38 .XX: ±0.25 .XXX: ±0.13 | | X': ±3" X'': ±2" X'X': ±1" | |
| APPD. | JM_Zheng | NAME: TYPE-C 24P 公头 拉伸款 两脚插 端子SMT+DIP 沉板0.95 L=14.65 CH=0.25 编带 | |
| CHKD. | LYX | PJ. NO.: 126-123-240001-J8G | |
| DR. | TSP | SIZE: A4 DRW NO.: H0019-24-F01-B | |
| PDWG.NO: 0500-1 | | FINISH: SEE NOTES MAT'L.: SEE NOTES | |
| | | SCALE: N/A REV.: A0 UNIT: mm PAGE: 2/2 | |