

RECOMMENDED P.C.B. LAYOUT  
TOLERANCE UNSPECIFIED ±0.05mm

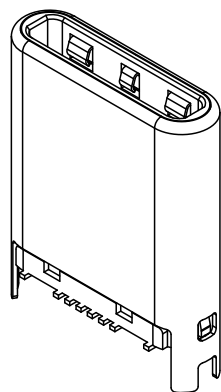
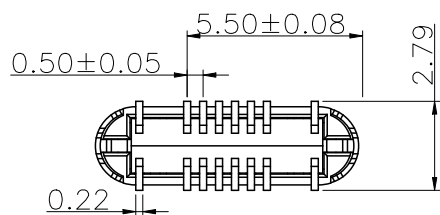
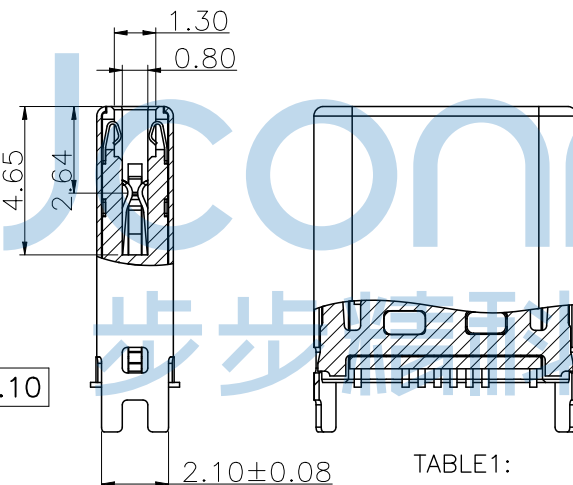
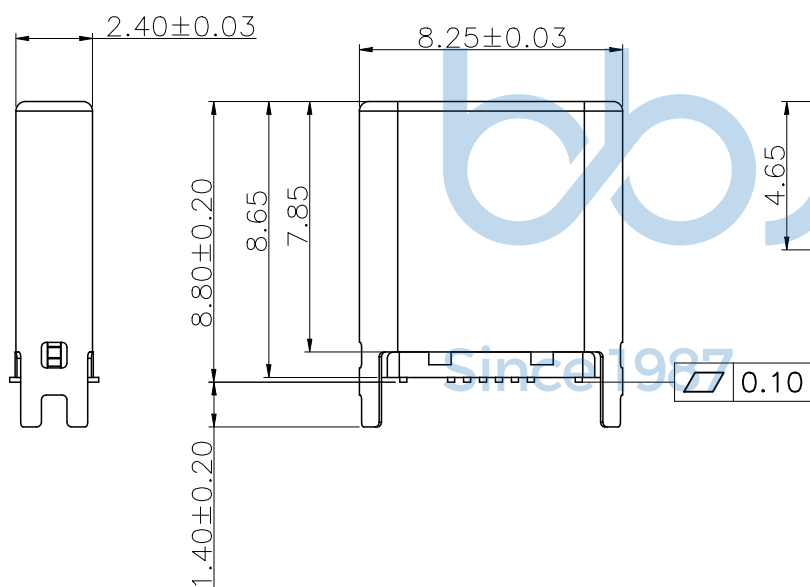

REV.	ECN NO	CONTENT	DATE	ENGINEER
A0		Initial release	/	TSP

NOTES:

- Material: SEE TABLE1;
- Plating specification,
  - Contact: Contact area: Ni50u"Min/Au Solder area: Ni50u"Min/Sn100u"Min. Other area: Ni 50u"Min.
  - Shell: NI.
  - Latch: Solder area: Ni50u"Min/Sn100u"Min. Other area: Ni 50u"Min.
- Mechanical Performance ,
  - Insertion Force: 5~20N;
  - Extraction Force: 6~20N after 10000 cycles;
  - Durability: 10000 cycles.
- Electrical Performance,
  - Insulation Resistance: 100? Min.
  - Contact Resistance :50m? Max.
  - Dielectric Strength :100V AC.
- characteristic impedance: 100 Ohm±10%;
- Marked "▼" is the important control dimentions.
- The product accords with HF STD.



TABLE1:

5	EMC SPRING	Stainless Steel; SUS301, T=0.08mm;
4	CONTACT	Copper Alloy; AuNiSn;
3	LATCH	Stainless Steel; SUS301, T=0.40mm;
2	HOUSING	LCP Thermoplastic, UL94V-0;
1	SHELL	Stainless Steel; SUS316L, T=0.15mm;
NO.	NAME	DESCRIPTION

THIS DOCUMENT IS THE SOLE PROPERTY OF BBJconn Technology Co., Ltd. Corporation AND SHOULD NOT BE USED IN WHOLE OR IN PART WITHOUT PRIOR WRITTEN PERMISSION. PDWG.NO: 0500-1

**深圳市步步精科技有限公司**

NAME: TYPE-C 16P 公头 直立式 贴片 端子SMT 带EMC H=8.65

PJ. NO.: 126-124-160003-J8G

SIZE: A4 DRW NO.:

FINISH: SEE NOTES MAT'L.: SEE NOTES

SCALE: N/A REV.: A0 UNIT: mm PAGE: 1/2

REV.	ECN NO	CONTENT	DATE	ENGINEER
A0		Initial release	/	TSP

NOTE:

1. QUANTITY/REEL: 500 PCS  
數量/卷: 500 PCS  
QUANTITY/INNER CARTON: 500 X 10 = 5000 PCS  
數量/箱: 500 X 10 = 5000 PCS  
2. FREE 14 CAVE IN THE FRONT CARRIER AND FREE 14 CAVE IN THE END CARRIER.  
包裝帶內圈空26格, 外圈空26格.

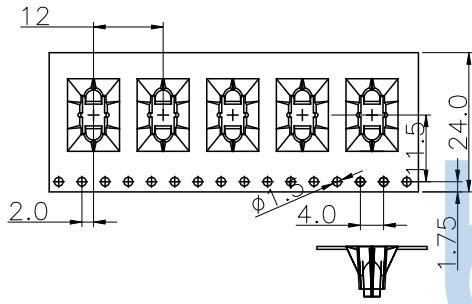
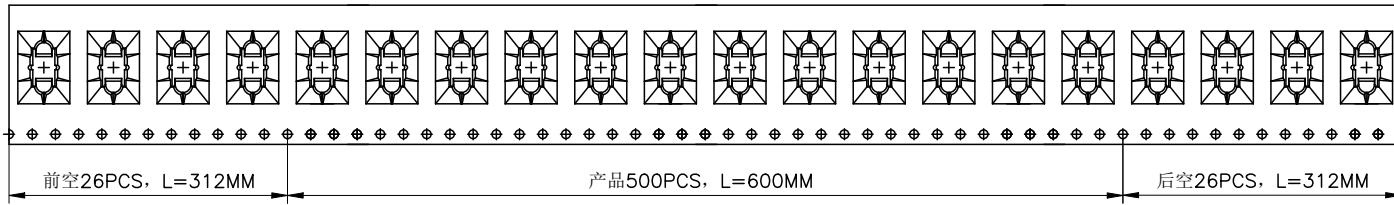

① 产品入载带示意图

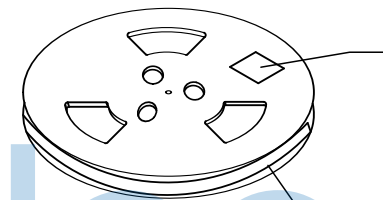

② 卷盘贴标签示意图

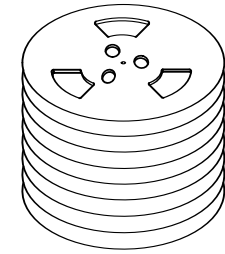

③ 10盘产品叠层示意图

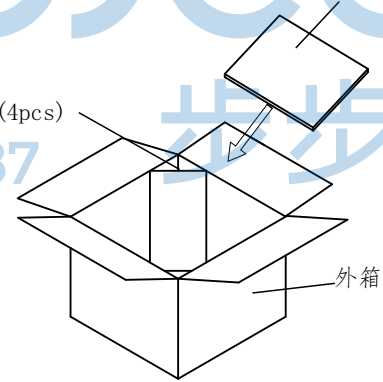

④ 产品入外箱示意图

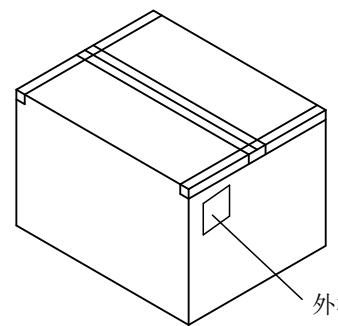

⑤ 外箱封箱示意图

1	卷盘	PS	ø330MM*W28.5MM	10
2	天地板	K3K		2
3	外标签			1
4	三角柱	K=K		4
5	外箱	A=A	L345mm*W345mm*315mm	1
6	防水袋	PS		1
7	干燥剂			1
ITEM	DESC.	MATERIAL	REMARKS	QTY



THIS DOCUMENT IS THE SOLE PROPERTY OF BBJconn Technology Co., Ltd. CORPORATION AND SHOULD NOT BE USED IN WHOLE OR IN PART WITHOUT PRIOR WRITTEN PERMISSION.

**深圳市步步精科技有限公司**

NAME: TYPE-C 16P 公头 直立式 贴片 端子SMT 带EMC H=8.65

APPD. JM\_Zheng

CHKD. LYX

DR. TSP

PJ. NO.: 126-124-160003-J8G

SIZE: A4 | DRW NO.:

FINISH: SEE NOTES | MAT'L.: SEE NOTES

SCALE: N/A | REV.: A0 | UNIT: mm | PAGE: 2/2

PDWG. NO: 0500-1