

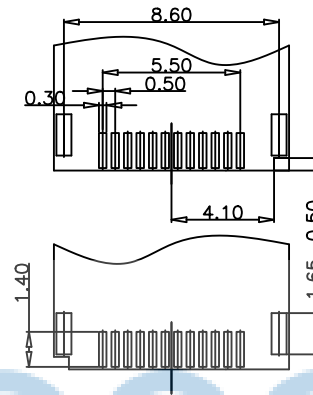

| REV. | ECN NO | CONTENT         | DATE | ENGINEER |
|------|--------|-----------------|------|----------|
| A0   |        | Initial release | /    | GZY      |

NOTE:

- MATERIAL SPECIFICATION:
  - HOUSING: HIGH TEMPERATURE RESISTANT PLASTIC, UL94 V-0.
  - CONTACTS: COPPER ALLOY
  - MID PLATE: STAINLESS STEEL
  - FRONT SHELL: STAINLESS STEEL
- PLATING SPECIFICATION:
  - CONTACTS:
    - Ni 50u" MIN. UNDER PLATED OVER ALL.
    - Au PLATED ON THE FUNCTIONAL AREA OF CONTACT. (GOLD PLATING THICKNESS FOLLOW THE P/N)
    - PLATING SPECIFICATIONS OF THE SOLDER AREA FOLLOW THE P/N
  - FRONT SHELL:
    - Ni 30u" MIN. UNDER PLATED OVER ALL.
  - SHIELD PLATE & EMI PLATE: CLEAR ONLY
- MECHANICAL PERFORMANCE,
  - INSERTION FORCE: 0.5~2.0kgf.
  - REMOVAL FORCE: 0.8kgf~2.0kgf.
  - DURABILITY: 10000 CYCLES.
- ELECTRICAL PERFORMANCE,
  - CURRENT RATING: 3.0A FOR VBUS; 1.25A MAX FOR OTHER. VOLTAGE RATING: 5.0V
  - LLCR:
    - VBUS & GND PINS AND OTHER PINS: 40m"/PIN MAX. SHIELD: 50m"/MAX.
    - LLCR MAX. CHANGE OF ALL PINS: 10m".
  - INSULATION RESISTANCE: 100MΩ MIN
  - DIELECTRIC WITHSTAND VOLTAGE, AC 100V FOR 1 MINUTE.
- ENVIRONMENTAL PERFORMANCE:
  - OPERATING TEMPERATURE: -25°C~+85°C.
- IR REFLOW:
  - THE PEAK TEMPERATURE ON THE BOARD SHALL BE MAINTAINED FOR 10 SECONDS AT 260°C.
- SALT SPRAY TEST: 24H

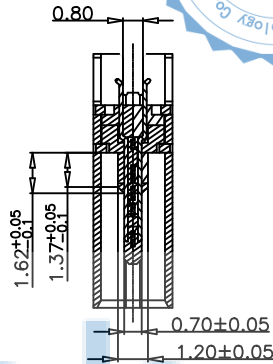
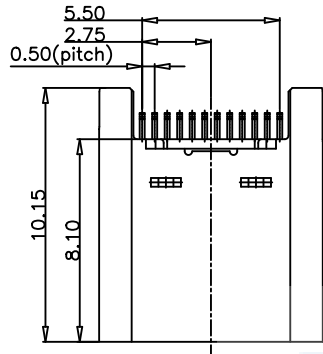

RECOMMENDED P.C.B. LAYOUT (T: 0.80mm)  
TOLERANCE UNSPECIFIED ±0.05mm

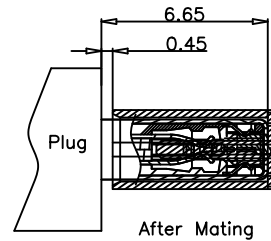
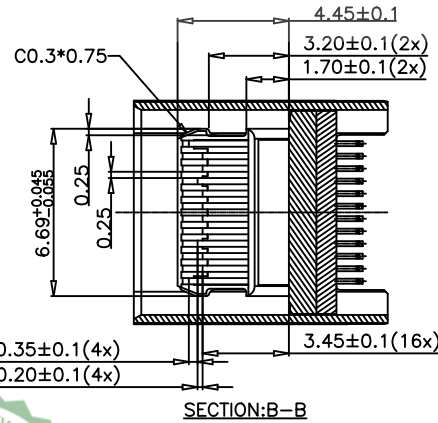
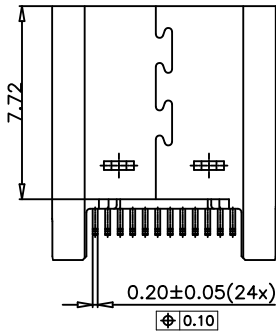
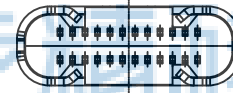
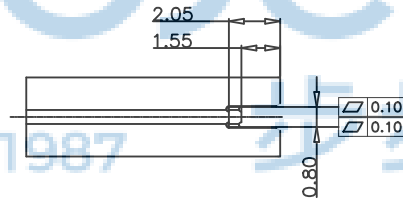
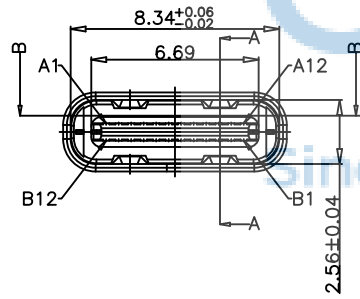

USB TYPE-C PIN ASSIGNMENTS

| PIN NUMBER | SIGNAL NAME | PIN NUMBER | SIGNAL NAME |
|------------|-------------|------------|-------------|
| A1         | GND         | B12        | GND         |
| A2         | SSTXp1      | B11        | SSRXp1      |
| A3         | SSTXn1      | B10        | SSRXn1      |
| A4         | VBUS        | B9         | VBUS        |
| A5         | CC1         | B8         | SBU2        |
| A6         | Dp1         | B7         | Dn2         |
| A7         | Dn1         | B6         | Jp2         |
| A8         | SBU1        | B5         | CC2         |
| A9         | VBUS        | B4         | VBUS        |
| A10        | SSRXn2      | B3         | SSTXn2      |
| A11        | SSRXp2      | B2         | SSTXp2      |
| A12        | GND         | B1         | GND         |



THIS DOCUMENT IS THE SOLE PROPERTY OF BBJconn Technology Co., Ltd. Corporation AND SHOULD NOT BE USED IN WHOLE OR IN PART WITHOUT PRIOR WRITTEN PERMISSION. PDWG.NO: 0500-1

**深圳市步步精科技有限公司**

NAME: TYPE-C 24P 母座 直立式 夹板0.80 H=8.10 不锈钢外壳 LCP黑色 盒装

APPD. JM\_Zheng  
CHKD. LYX  
DR. GZY

PJ. NO.: 126-22A-240005-J8G  
SIZE: A4 | DRW NO.:  
FINISH: SEE NOTES | MAT'L.: SEE NOTES  
SCALE: N/A | REV.: A0 | UNIT: mm | PAGE: 1/2



一.  
將成品依同一方向放入真空盤內, 如圖所示.

At same direction, put product onto the tray.  
Direction refers to below drawing.

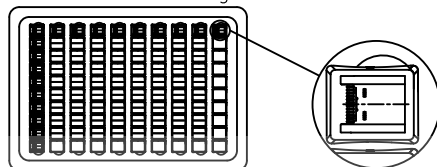

VIEW-1

二.

1) 一只紙箱可放置之包裝盤(包括上蓋)見下表.

1) trays per carton, please see next table.

2). 每1個紙箱用的包裝數量詳見下表.

2) The Q'ty of products per carton please see next table.

3) 將裝滿成品的真空盤用 PE帶捆緊後放在塑膠袋內, 裝完後再封箱.

3) Bind the trays with PE tape and then, put them into the poly bag. Seal the carton with tape.



VIEW-2

三.

1). 將標籤貼於紙箱側上方.  
Stick the needful label On the up-right corner of the side of carton.

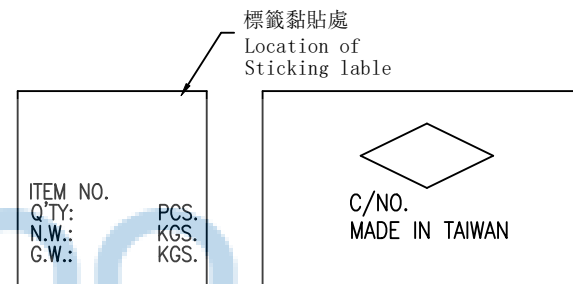

VIEW-3

備註(REMARK)

- 若有未裝滿之零數箱, 必須以緩衝材塞滿.  
The unfilling-carton must be filled with assuagement.
- 防水袋需用膠帶貼實且封口.  
waterproof plastic bag must be folded up.
- 裝滿成品后之外箱, 最大堆積箱數: 5箱  
About the box fully filled with products, the MAX accumulating quantity of boxes is 5.
- 如須貼Bar-code, 請依Bar-code 作業辦法執行  
If barcode label is required, do it according to the related barcode label operation standards.



包裝明細表 (The detail of the packing)

| 產品料號<br>(Product No.) | 包裝容量 (Packing Capacity) |              |         | 重量 Weight (Kg) |          |          |
|-----------------------|-------------------------|--------------|---------|----------------|----------|----------|
|                       | pcs/box                 | boxes/Carton | Pcs/Box | N.W./Pcs       | N.W./Box | G.W./Box |
|                       | 100                     | 80           | 8000    |                |          |          |

|  |          |   |     |   |     |
|--|----------|---|-----|---|-----|
| THIS DOCUMENT IS THE SOLE PROPERTY OF BBJconn Technology Co.,Ltd. Corporation AND SHOULD NOT BE USED IN WHOLE OR IN PART WITHOUT PRIOR WRITTEN PERMISSION. |          | <b>深圳市步步精科技有限公司</b><br>.X: ±0.38 .X': ±3"<br>.XX: ±0.25 .X': ±2"<br>.XXX: ±0.13 .XX': ±1" |     | NAME: TYPE-C 24P 母座 直立式 夹板0.80 H=8.10 不锈钢外壳 LCP黑色 盒装<br>PJ. NO.: 126-22A-240005-J8G<br>SIZE: A4 DRW NO.:<br>FINISH: SEE NOTES MAT'L.: SEE NOTES<br>SCALE: N/A REV.: A0 UNIT: mm PAGE: 2 / 2 |     |
| APPD.  | JM_Zheng | CHKD.   | LYX | DR.   | GZY |
| PDWG.NO:   | 0500-1   |   |     |   |     |