

REV.	ECN NO	CONTENT	DATE	ENGINEER
A0			2023 20/04	

NOTES:

1.MATERIAL SPECIFICATION:

- 1.HOUSING:HIGH TEMPERATURE RESISTANT PLASTIC,LCP UL94 V-0 Black.
- 2.CONTACTS:COPPER ALLOY,C7025.
- 3.MID-PLATED:STANLESS STEEL,SUS301.
- 4.Shell:STANLESS STEEL,SUS304.

2.PLATING SPECIFICATION:

2-1.CONTACTS:

- Ni 50u" MIN. UNDER PLATED OVER ALL.
- Au G/F PLATED ON THE FUNCTIONAL AREA OF CONTACT.  
(GOLD PLATING THICKNESS FOLLOW)
- GOLD FLASH PLATING ON SOLDER AREA
- Ni 30u" MIN. UNDER PLATED OVER ALL.

3.MECHANICAL:

- INSERTION: 5~20N.
- EXTRACTION: 8~20N.
- DURABILITY: 10000 CYCLES

4.ELECTRICAL:

- CURRENT: 5A MIN FOR VBUS;  
0.25A MIN FOR OTHER.
  - VOLTAGE: 5VAC MAX
  - WITHSTANDING VOLTAGE: 100V AC.
  - CONTACT RESISTANCE: 40mΩ MAX.
  - INSULATION RESISTANCE: 100MΩ MIN.
- 5.ENVIRONMENTAL  
TEMPERATURE RANGE -55°C ~ +85°C

NO.	DIM A	DIM B
1	10.5	6.2
2	9.3	5.0
3	8.8	4.8
4	10.0	5.7

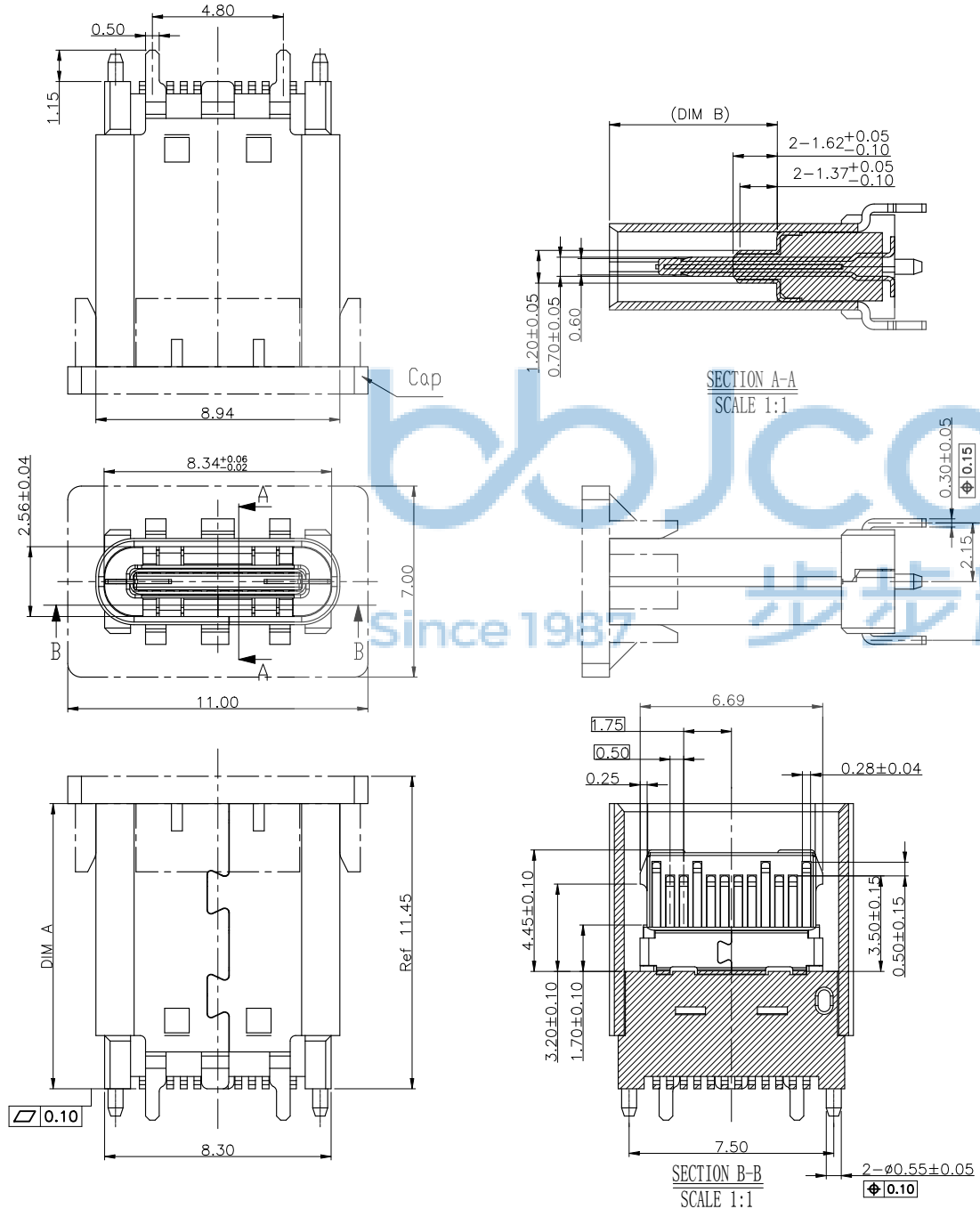

THIS DOCUMENT IS THE SOLE PROPERTY OF BBJconn Technology Co.,Ltd. Corporation AND SHOULD NOT BE USED IN WHOLE OR IN PART WITHOUT PRIOR WRITTEN PERMISSION.		 <b>深圳市步步精科技有限公司</b> 工程部	
APPD.	JM_Zheng 23/05'02	NAME:	TYPE-C 24P 母座 直立式 H=10.0 四脚插 带柱 端子SMT
CHKD.	TSP 23/05'02	PJ. NO.:	126-224-240004-G8G
DR.	LYX 23/05'02	SIZE: A4	DRW NO.:
PDWG.NO:	0046-1	FINISH: SEE NOTES	MAT'L.: SEE NOTES
		SCALE: N/A	REV.: A0 UNIT: mm PAGE: 1/1



USB TYPE-C FULL-FEATURED RECEPTACLE INTERFACE PIN ASSIGNMENTS

PIN	Signal Name	Description	PIN	Signal Name	Description
A1	GND	Ground return	B12	GND	Ground return
A2	SSTXp1	Positive half of first SuperSpeed TX differential pair	B11	SSTXp1	Positive half of first SuperSpeed TX differential pair
A3	SSTXn1	Negative half of first SuperSpeed TX differential pair	B10	SSTXn1	Negative half of first SuperSpeed TX differential pair
A4	VBUS	Bus Power	B9	VBUS	Bus Power
A5	CC1	Configuration Channel	B8	CC1	Configuration Channel
A6	Dp1	Positive half of the USB 2.0 differential pair-Position 1	B7	Dp1	Positive half of the USB 2.0 differential pair-Position 1
A7	Dn1	Negative half of the USB 2.0 differential pair-Position 1	B6	Dn1	Negative half of the USB 2.0 differential pair-Position 1
A8	RFU1	Reserved for Future Use (RFU)	B5	RFU1	Reserved for Future Use (RFU)
A9	VBUS	Bus Power	B4	VBUS	Bus Power
A10	SSRXn2	Negative half of second SuperSpeed RX differential pair	B3	SSRXn2	Negative half of second SuperSpeed RX differential pair
A11	SSRXp2	Positive half of second SuperSpeed RX differential pair	B2	SSRXp2	Positive half of second SuperSpeed RX differential pair
A12	GND	Ground return	B1	GND	Ground return

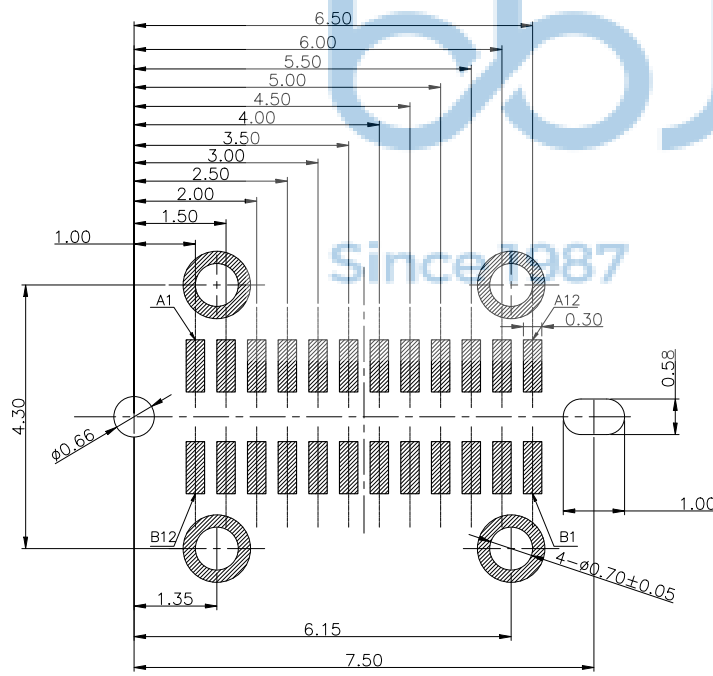
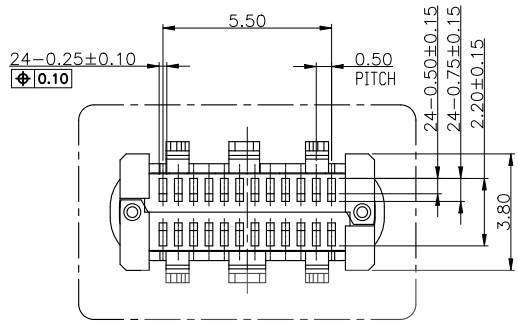

RECOMMENDED P.C.B. LAYOUT (T:1.00mm)  
TOLERANCE UNSPECIFIED ±0.05mm



THIS DOCUMENT IS THE SOLE PROPERTY OF BBJconn Technology Co.,Ltd. Corporation AND SHOULD NOT BE USED IN WHOLE OR IN PART WITHOUT PRIOR WRITTEN PERMISSION.		深圳市步步精科技有限公司 .X: ±0.38    .X': ±3"    NAME: .XX: ±0.25    .X": ±2"    TYPE-C 24P 母座 直立式 H=10.0 四脚插 带柱 端子SMT .XXX: ±0.13    .XX': ±1"	
APPD.	JM_Zheng 23/05'02	PJ. NO.: 126-224-240004-G8G SIZE: A4 DRW NO.:	
CHKD.	TSP 23/05'02		
PDWG.NO:	0046-1	FINISH: SEE NOTES    MAT'L.: SEE NOTES SCALE: N/A    REV.: A0    UNIT: mm    PAGE: 1/2	
DR.	LYX 23/05'02		

出料方向  
PULL OUT DIRECTEON

NOTES

1.帶子引導長度  
LEAD TAPE LENGTH  
出料方向  
PULL OUT DIRECTEON

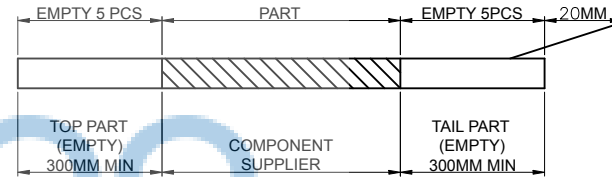
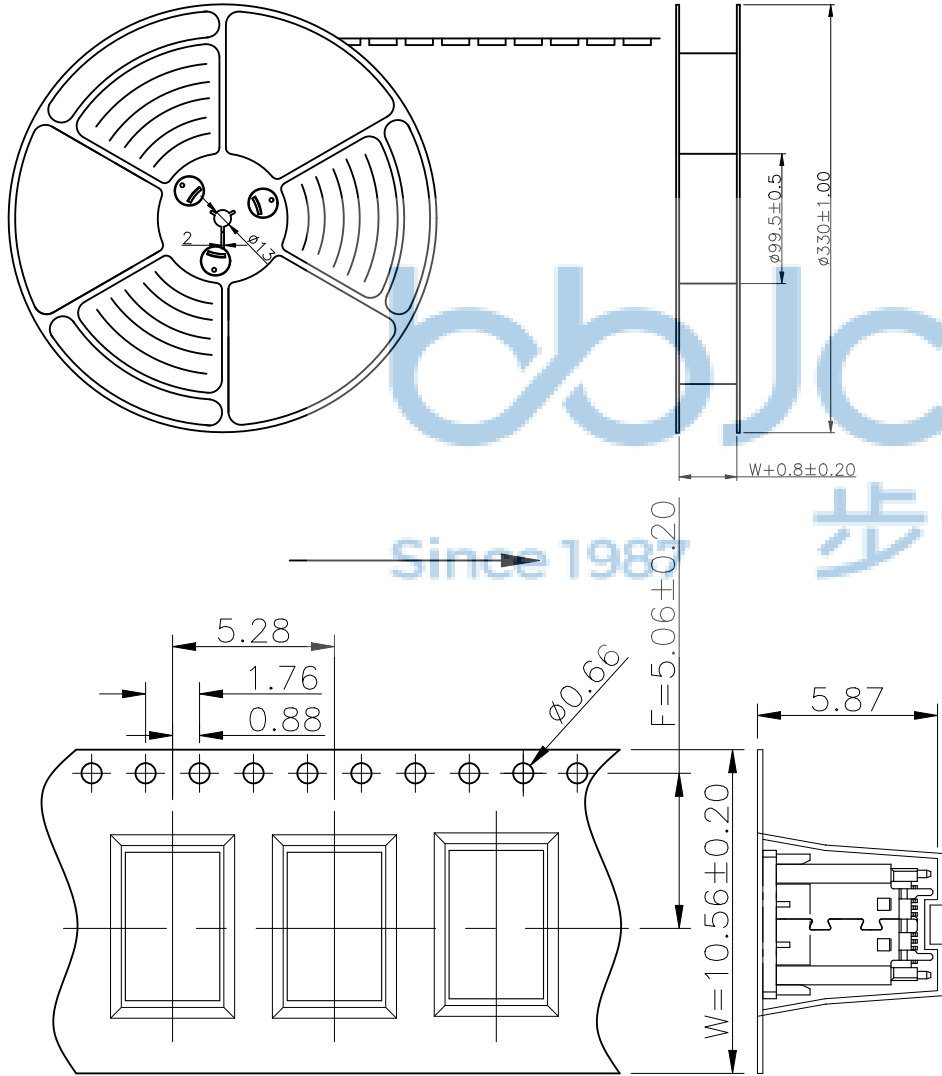

2.上帶 剝力為 : 0.1~1.3N(10.2gf~130gf)  
PEELING OFF FORCE OF TOP TAPE:0.1~1.3N(10.2gf~130gf)  
出貨運輸過程中一定注意:  
THIS REQUIREMENT SHOULD BE APPLIED AT SHIPMENT:  
卷帶在運輸過程中不能散開  
PEELING OFF SHOULD NOT BE ALLOWED DURING TRANSPORTATION

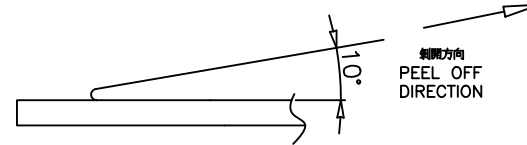

THIS DOCUMENT IS THE SOLE PROPERTY OF BBJconn Technology Co.,Ltd. Corporation AND SHOULD NOT BE USED IN WHOLE OR IN PART WITHOUT PRIOR WRITTEN PERMISSION.		<b>深圳市步步精科技有限公司</b>	
PDWG:NO: 0046-1		NAME: TYPE-C 24P 母座 直立式 H=10.0 四脚插 带柱 端子SMT	
APPD.	JM_Zheng 23/05'02	PJ. NO.: 126-224-240004-G8G	
CHKD.	TSP 23/05'02	SIZE: A4 DRW NO.:	
DR.	LYX 23/05'02	FINISH: SEE NOTES MAT'L.: SEE NOTES	
		SCALE: N/A	REV.: A0 UNIT: mm PAGE: 1/3

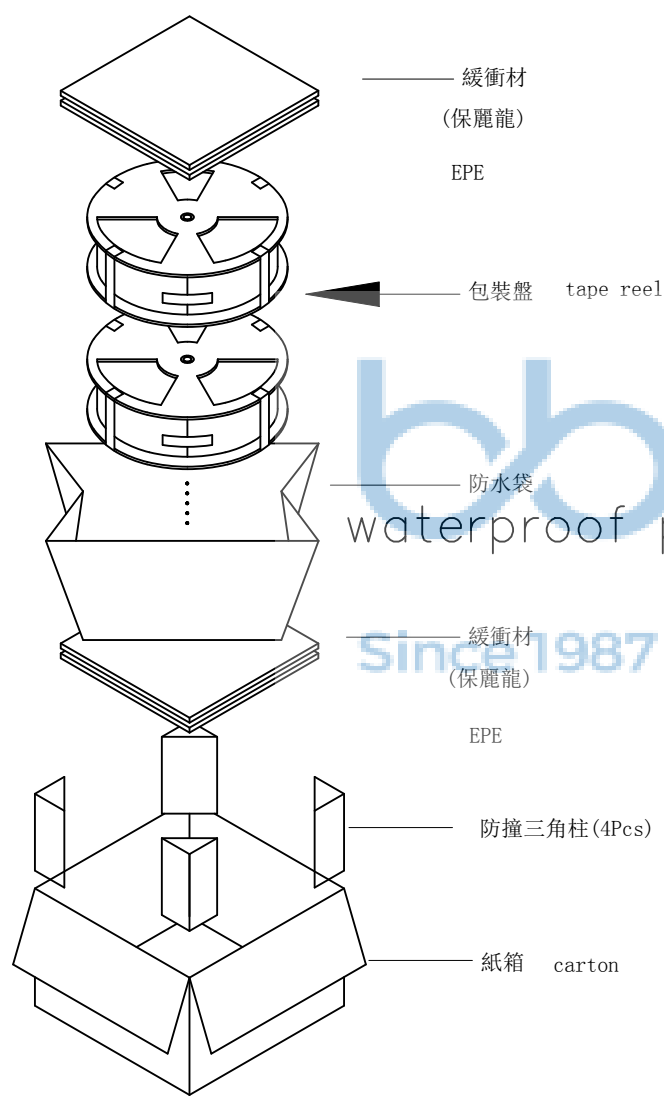

at small positioning hole of the carrier tape side).  
標籤黏貼處 (朝捲裝包材的小定位孔一側)  
Location of label sticking (label)

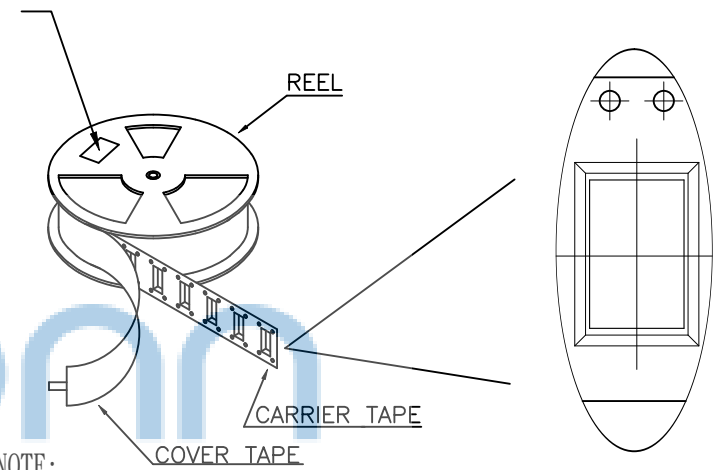

- NOTE:
1. 每捲包裝數量及每箱裝箱數量如左下表格。  
Packing q'ty of each reel & carton as below table shown.
  2. 以上膠帶覆蓋下包裝帶經包裝機熱熔包裝  
Use cover tape to cover and hot melt machine to seal up.
  3. 每個紙箱放2個珍珠棉  
Every carton use 2pcs EPE.
  4. 將裝滿產品的卷盤放入紙箱并以膠帶封口  
Put reels in the carton and use adhesive tape to seal up.



產品料號 (PRODUCT No.)	包裝容量 (PACKING CAPACITY)			重量 WEIGHT (Kg)		
	PCS/REEL	REELS/CARTON	PCS/CARTON	N.W./PCS	N.W./BOX	G.W./BOX
	450	8	3600			

THIS DOCUMENT IS THE SOLE PROPERTY OF BBJconn Technology Co.,Ltd. Corporation AND SHOULD NOT BE USED IN WHOLE OR IN PART WITHOUT PRIOR WRITTEN PERMISSION.		深圳市步步精科技有限公司 .X: ±0.38    .XX: ±0.25    .XXX: ±0.13 X': ±3"    X'': ±2"    XX': ±1"		NAME: TYPE-C 24P 母座 直立式 H=10.0 四脚插 帶柱 端子SMT PJ. NO.: 126-224-240004-G8G SIZE: A4   DRW NO.: FINISH: SEE NOTES   MAT'L.: SEE NOTES SCALE: N/A   REV.: AO   UNIT: mm   PAGE: 1/4	
APPD.	JM_Zheng	23/05'02			
CHKD.	TSP	23/05'02			
PDWG.NO:	0046-1	DR.	LYX	23/05'02	