

REV.	ECN NO	CONTENT	DATE	ENGINEER
A0		Initial release	/	ZY

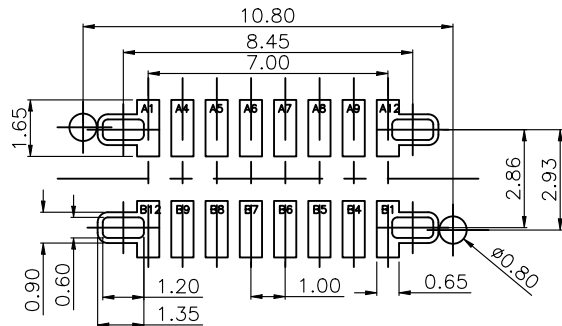
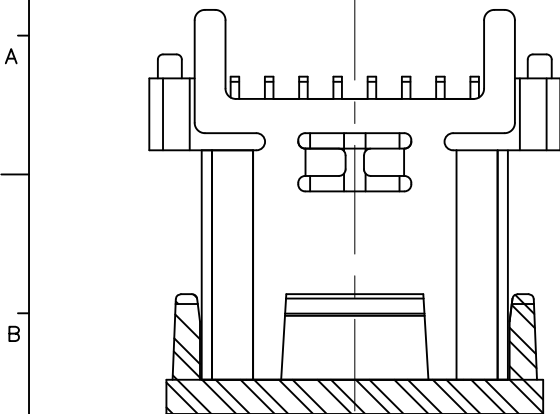

RECOMMENDED P.C.B. LAYOUT (T:1.00mm)
TOLERANCE UNSPECIFIED $\pm 0.05\text{mm}$

SPECIFICATIONS:

- ELECTRICAL CHARACTERISTICS:
 - CONTACT RESISTANCE: 30m MAX. Ω
 - DIELECTRIC WITHSTANDING VOLTAGE: 100V AC FOR ONE MINUTE.
 - INSULATION RESISTANCE: 100M MIN. MEASURED BY 500 VDC
- MECHANICAL CHARACTERISTICS:
 - INSERTION FORCE : 0.5-2.0Kgf (REF.)
 - WITHDRAWAL FORCE : 0.8-2.0Kgf (REF.)
- LIFE TEST: 10,000 CYCLES.

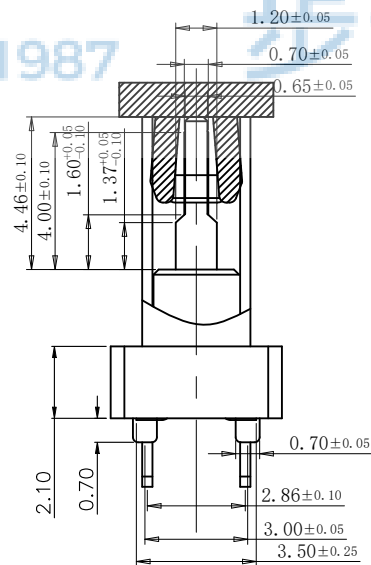
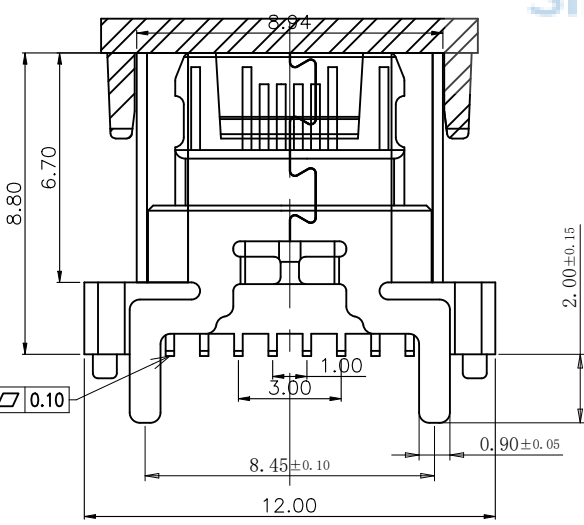
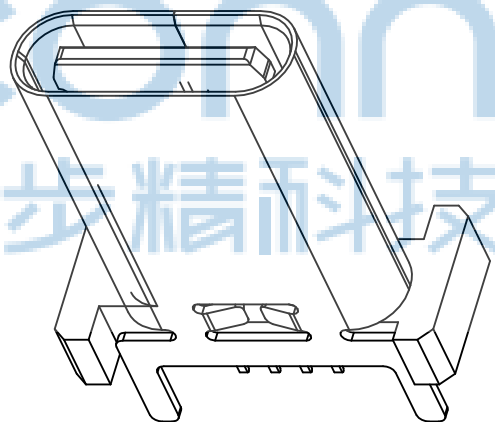
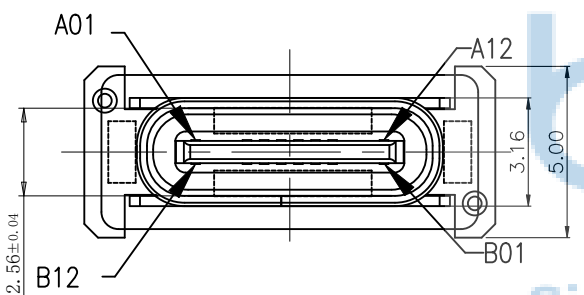

A1	GND	B12	GND
A4	VBUS	B9	VBUS
A5	CC1	B8	SBU2
A6	DP1	B7	DN2
A7	DN1	B6	DP2
A8	SBU1	B5	CC2
A9	VBUS	B4	VBUS
A12	GND	B1	GND
PIN	SIGNAL NAME	PIN	SIGNAL NAME

THIS DOCUMENT IS THE SOLE PROPERTY OF BBJconn Technology Co., Ltd. Corporation AND SHOULD NOT BE USED IN WHOLE OR IN PART WITHOUT PRIOR WRITTEN PERMISSION. PDWG.NO: 0545-1

深圳市步步精科技有限公司

NAME: TYPE-C 16P 母座
直立式 SMT 四脚插 H=8.80 编带

APPD. JM_Zheng
CHKD. LYX
DR. ZY

PJ. NO.: 126-224-240001-N7G
SIZE: A4 DRW NO.:
FINISH: SEE NOTES MAT'L: SEE NOTES
SCALE: N/A REV.: A0 UNIT: mm PAGE: 1/2

REV.	ECN NO	CONTENT	DATE	ENGINEER
A0		Initial release	/	ZY

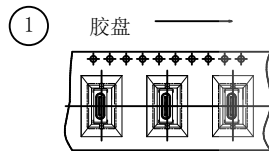
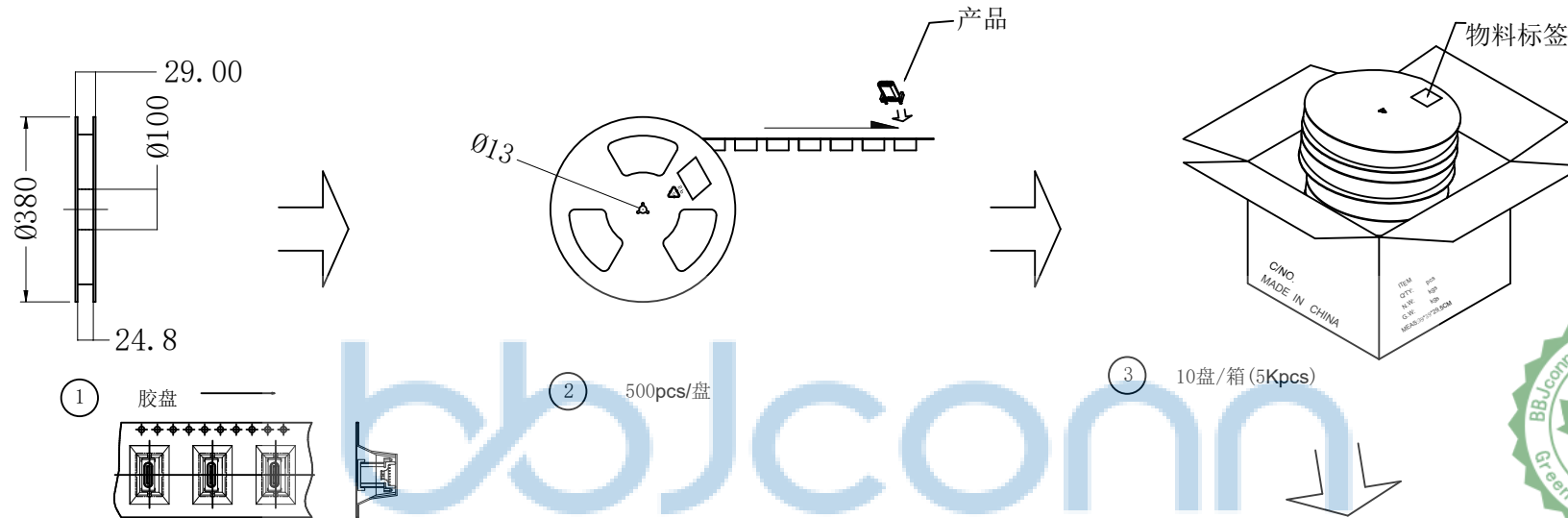

② 500pcs/盘

③ 10盘/箱 (5Kpcs)

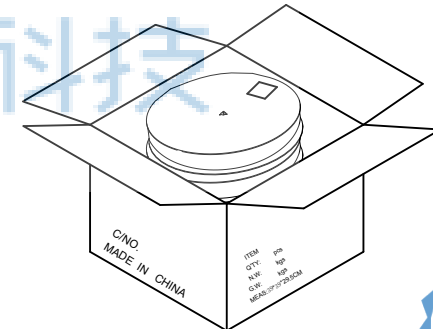
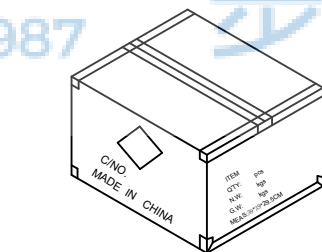
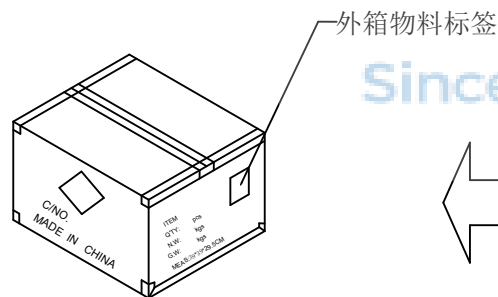

备注:

- 胶盘规格: 外圆*内圆*厚: 380*13*26mm
- 每箱装10盘 (5Kpcs);
- 外箱尺寸: 长*宽*高: 39*39*31.0cm
材质: A=B;
- 外箱用透明胶纸带封“工”字型;
- 依外箱图示位置粘贴好产品或ROHS标签.

THIS DOCUMENT IS THE SOLE PROPERTY OF BBJconn Technology Co., Ltd.		深圳市步步精科技有限公司	
NOT BE USED IN WHOLE OR IN PART WITHOUT PRIOR WRITTEN PERMISSION.		.X: ±0.38 .XX: ±0.25 .XXX: ±0.13	X: ±3' .X: ±2' .XX: ±1'
APPD.	JM_Zheng	NAME: TYPE-C 16P 母座 直立式 SMT 四脚插 H=8.80 编带	
CHKD.	LYX	P.J. NO.: 126-224-240001-N7G SIZE: A4 DRW NO.:	
PDWG.NO:	0545-1	FINISH: SEE NOTES SCALE: N/A	
DR.	ZY	MAT'L: SEE NOTES REV.: A0 UNIT: mm PAGE: 2/2	