

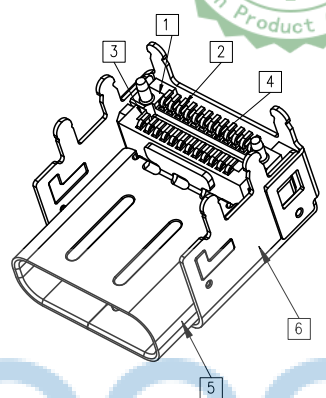

REV.	ECN NO	CONTENT	DATE	ENGINEER
A0		Initial release	/	TSP

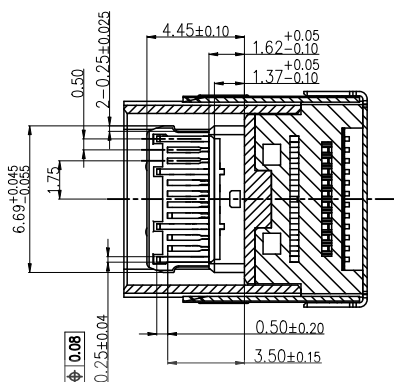
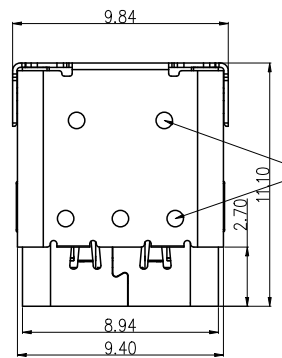

SECTION A-A

NOTES:
 1.MATERIAL :SEE TABLE
 2.COPLANARITY : 0.10 Max.
 3.ELECTRICAL CHARACTERISTICS
 LOW LEVEL CONTACT RESISTANCE: 40mΩ Max
 INSULATION RESISTANCE:100MΩ MIN
 DIELECTRIC WITHSTANDING VOLTAGE:100 VAC:
 CONTACT CURRENT RATING:5A Max
 4.MECHANICAL CHARACTERISTICS
 INSERTION FORCE: 5~20N
 EXTRACTION FORCE: 8~20N
 AFTER DURABILITY EXTRACTION FORCE: 6~20N
 5.DURABILITY: 10000 CYCLES
 6.PACKAGING TYPE: CARRIER TAPE.
 7.SALT SPRAY : 24 HOURS

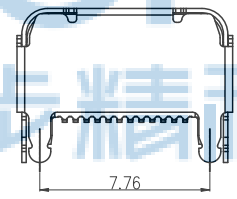
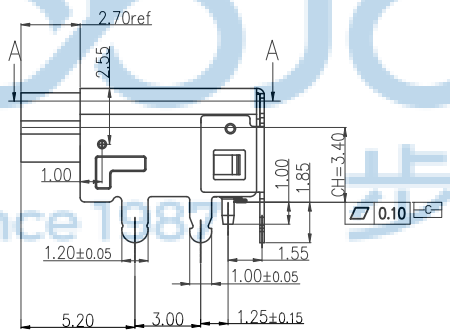
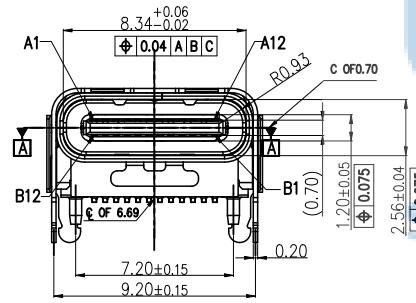

Pin No	Signal Name	Mating Sequence	Pin No	Signal Name	Mating Sequence
A1	GND	First	B12	GND	First
A2	TX1+	Second	B11	RX1+	Second
A3	TX1-	Second	B10	RX1-	Second
A4	Vbus	First	B9	Vbus	First
A5	CC1	Second	B8	SBU2	Second
A6	D+	Second	B7	D-	Second
A7	D-	Second	B6	D+	Second
A8	SBU1	Second	B5	CC2	Second
A9	Vbus	First	B4	Vbus	First
A10	RX2-	Second	B3	TX2-	Second
A11	RX2+	Second	B2	TX2+	Second
A12	GND	First	B1	GND	First

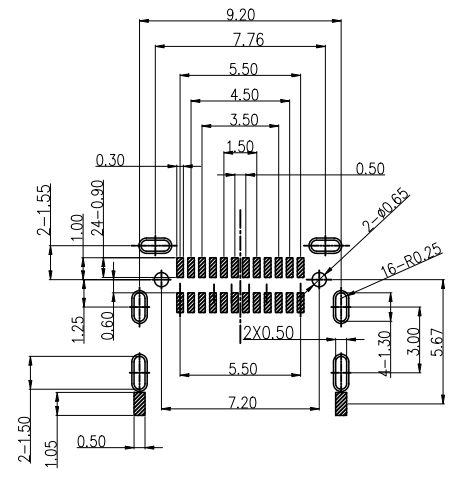
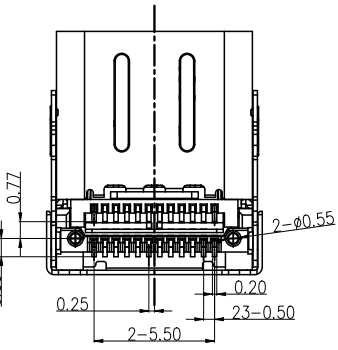

RECOMMENDED P.C.B LAYOUT (COMPONENT SIDE)
PCB THICKNESS: 2.0±0.05mm



ITEM	DESCRIPTION	Q'TY	MATERIAL	FINISH
6	OUTER-SHELL	1	STAINLESS STEEL	SOLDER NICKEL: 50U" MIN
5	INNER-SHELL	1	STAINLESS STEEL	SOLDER NICKEL: 50U" MIN
4	TOP TERMINAL	1	COPPER ALLOY	MATING AREA: AU 3u" SOLDER TAIL: MATTE TIN 100 MIN, 50u" NICKEL OVERALL.
3	BOTTOM TERMINAL	1	COPPER ALLOY	MATING AREA: AU 3u" SOLDER TAIL: MATTE TIN 100 MIN, 50u" NICKEL OVERALL.
2	MID PLATE	1	STAINLESS STEEL	SOLDER NICKEL: 50U" MIN
1	MAIN HOUSING	1	HIGH TEMPERATURE	BLACK

THIS DOCUMENT IS THE SOLE PROPERTY OF **bbJconn Technology Co., Ltd.** Corporation AND SHOULD NOT BE USED IN WHOLE OR IN PART WITHOUT PRIOR WRITTEN PERMISSION.

PDWG.NO: 0900-1

DR. TSP

APPD. JM_Zheng

CHKD. LYX

NAME: TYPE-C 24P 母座 双壳 垫高型 不短路款 双排SMT 镀金3u 板上六脚插 PH3.0 L=11.10 CH=3.40

PJ. NO.: 126-221-240001-J8G

SIZE: A4 DRW NO.:

FINISH: SEE NOTES MAT'L.: SEE NOTES

SCALE: N/A REV.: A0 UNIT: mm PAGE: 1/2

REV.	ECN NO.	CONTENT	DATE	ENGINEER
A0		Initial release	/	TSP

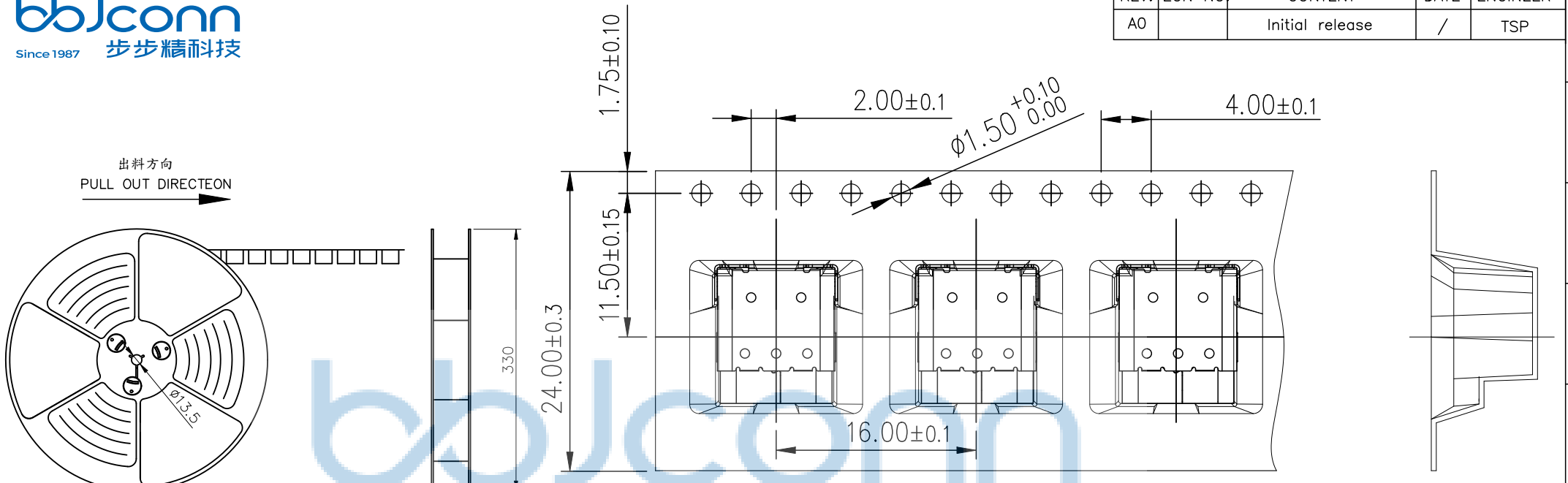

出料方向
PULL OUT DIRECTEON

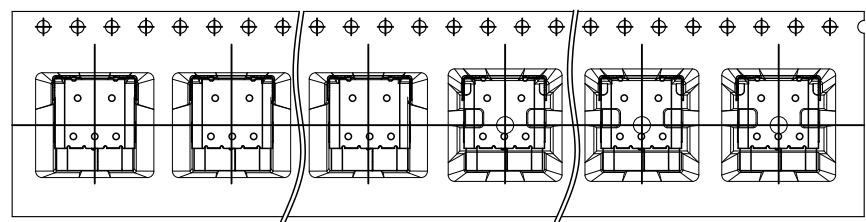
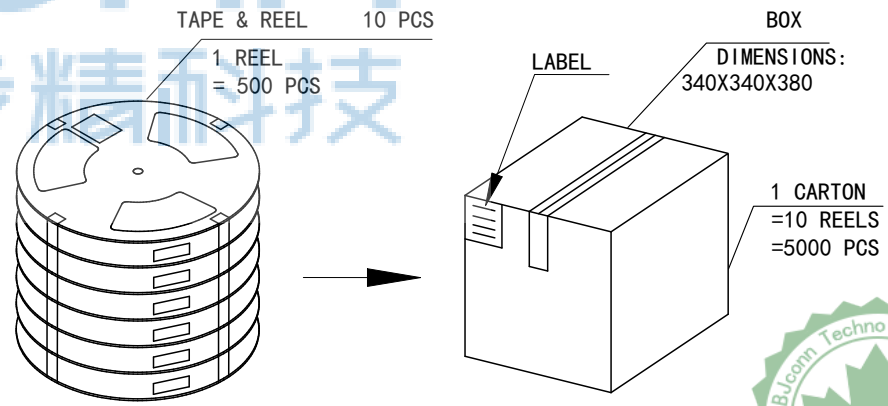

THIS DOCUMENT IS THE SOLE PROPERTY OF BBJconn Technology Co.,Ltd. Corporation AND SHOULD NOT BE USED IN WHOLE OR IN PART WITHOUT PRIOR WRITTEN PERMISSION.		深圳市步步精科技有限公司 .X: ±0.38 X': ±3' .XX: ±0.25 .X': ±2' .XXX: ±0.13 .XX': ±1'	
APPD.	JM_Zheng	PJ. NO.: 126-221-240001-J8G SIZE: A4 DRW NO.:	NAME: TYPE-C 24P 母座 双壳 垫高型 不短路款 双排SMT 镀金3u 板上六脚插 PH3.0 L=11.10 CH=3.40
CHKD.	LYX		FINISH: SEE NOTES MAT'L.: SEE NOTES
PDWG.NO:	0900-1	DR.	TSP
		SCALE: N/A	REV.: A0 UNIT: mm PAGE: 2/2