

REV.	ECN NO	CONTENT	DATE	ENGINEER
A0		Initial release	/	SGF

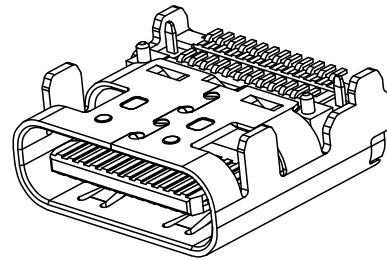

NOTE:

- 1.Contact Resistance:40mOHM Max.;
- 2.Dielectric Withstanding Voltage:100V AC For 1 Minute;
- 3.Insulation Resistance:100M OHM Min.;
- 4.Mating And Unmating Force:
Mating Force: 5~20N
Unmating Force: 8~20N;
6~20N AFTER TEST;
- 5.Durability:10000 Cycles;

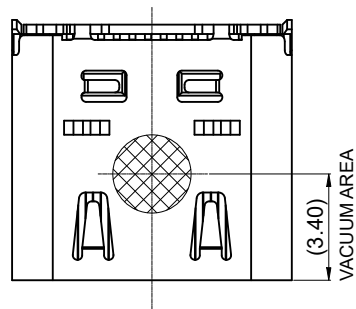
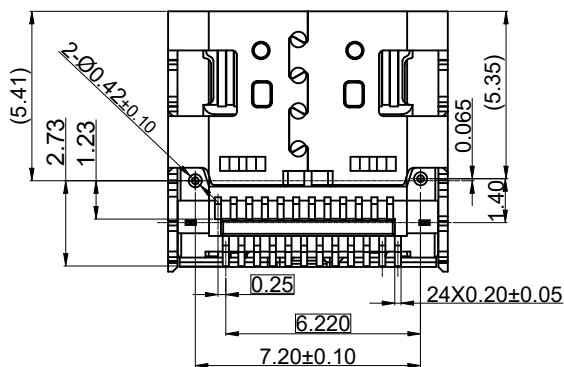
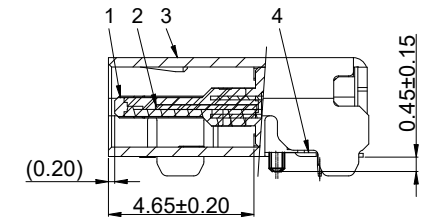
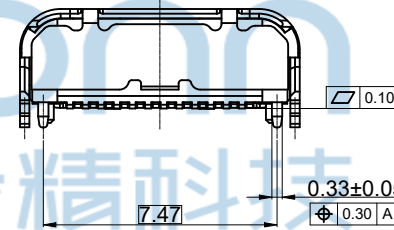
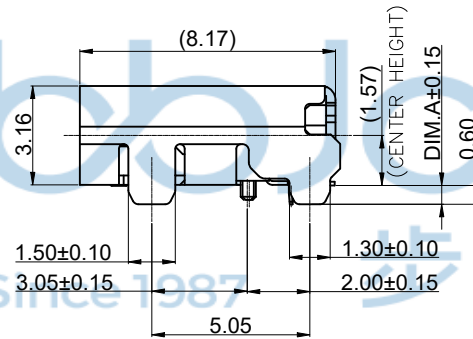
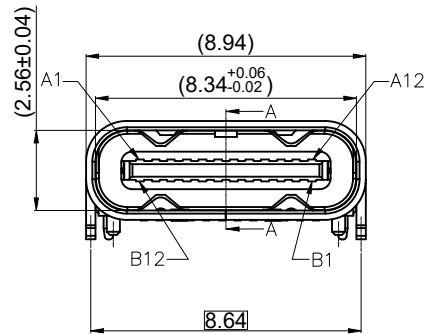

Item	Title	Material	Dispose	Q'TY
1	Shell	SUS304	Ni:50u" Min.	1PCS
2	GND Plate	SUS304		2PCS
3	Mid Plate	SUS301		1PCS
4	Contact	C18400	Mating Area: Au 1u" Solder Tails: Matt Tin	2SET
5	InsertMolding	LCP	UL 94V-0 Black	1PCS

THIS DOCUMENT IS THE
SOLE PROPERTY OF
BBJconn Technology Co.,Ltd.
Corporation AND SHOULD
NOT BE USED IN WHOLE
OR IN PART WITHOUT
PRIOR WRITTEN PERMISSION.
PDWG:NO: 0900-1

深圳市步步精科技有限公司		NAME: TYPE-C 24P 母座 双排SMT 板上四脚DIP 脚距8.64 带柱 带弹 L=8.17 CH=1.60 编带	
.X: ±0.38 .XX: ±0.25 .XXX: ±0.13	X': ±3" .X': ±2" .XX': ±1"	APPD.: JM_Zheng	P.J. NO.: 126-221-240004-J8G SIZE: A4 DRW NO.:
CHKD.: LYX	DR.: SGF	FINISH: SEE NOTES SCALE: N/A	MAT'L.: SEE NOTES REV.: A0 UNIT: mm PAGE: 1/3

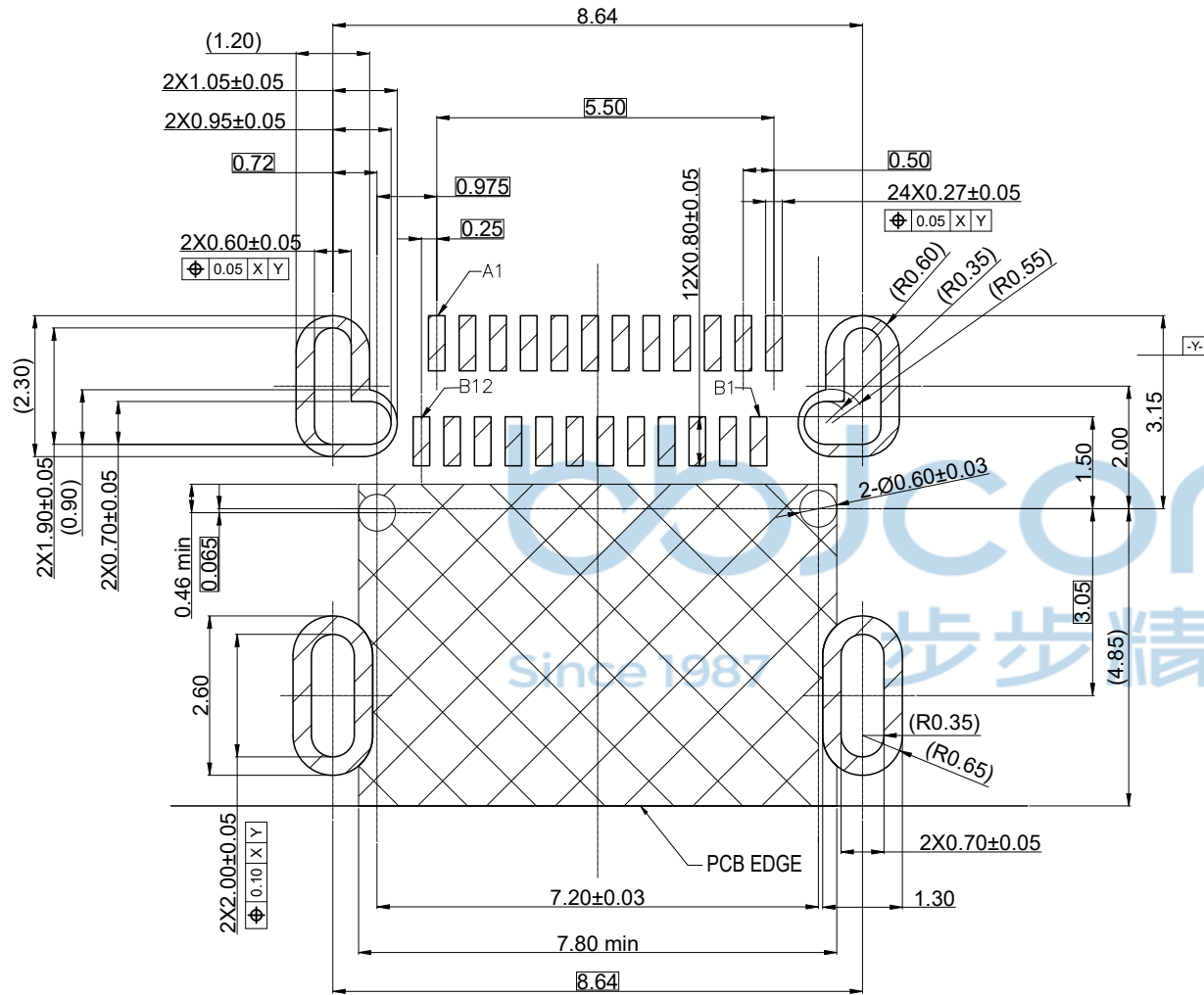

PIN ASSIGNMENT:

A1	A2	A3	A4	A5	A6	A7	A8	A9	A10	A11	A12
GND	TX1+	TX1-	Vbus	CC1	D+	D-	SBU1	Vbus	RX2-	RX2+	GND
GND	RX1+	RX1-	Vbus	SBU2	D-	D+	CC2	Vbus	TX2-	TX2+	GND
B12	B11	B10	B9	B8	B7	B6	B5	B4	B3	B2	B1



THIS DOCUMENT IS THE
SOLE PROPERTY OF
BBJconn Technology Co.,Ltd.
Corporation AND SHOULD
NOT BE USED IN WHOLE
OR IN PART WITHOUT
PRIOR WRITTEN PERMISSION.
PDWG.NO: 0900-1

深圳市步步精科技有限公司

.X: ±0.38	X': ±3'	NAME: TYPE-C 24P 母座 双排SMT 板上四脚DIP 脚距8.64 带柱 带弹 L=8.17 CH=1.60 编带
.XX: ±0.25	.X': ±2'	
.XXX: ±0.13	.XX': ±1'	
APPD.	JM_Zheng	P.J. NO.: 126-221-240004-J8G SIZE: A4 DRW NO.:
CHKD.	LYX	
DR.	SGF	FINISH: SEE NOTES SCALE: N/A
		MAT'L.: SEE NOTES REV.: A0
		UNIT: mm
		PAGE: 2/3

REV.	ECN NO	CONTENT	DATE	ENGINEER
A0		Initial release	/	SGF

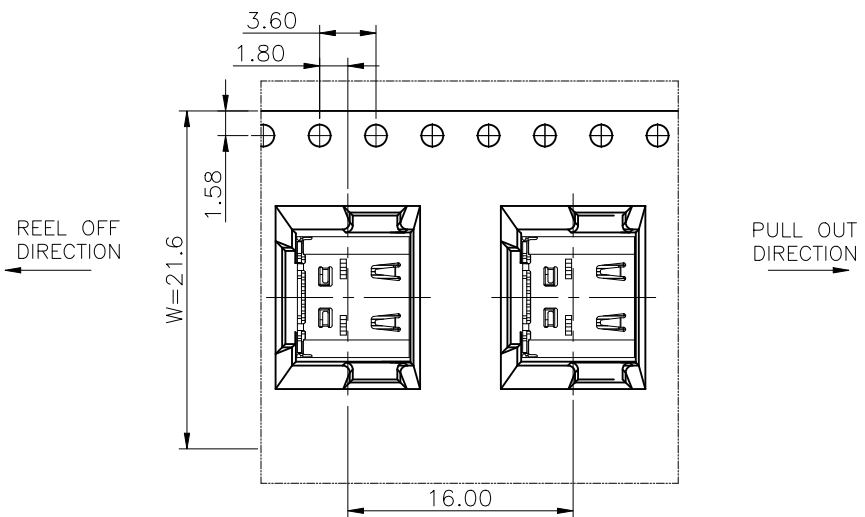
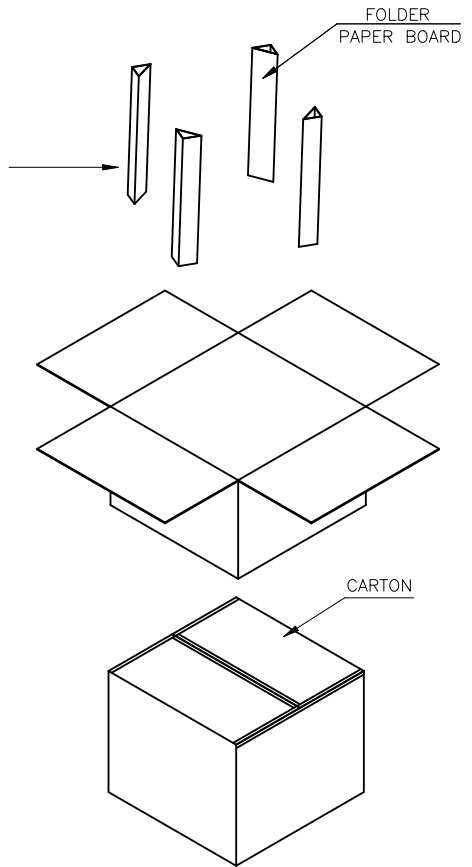
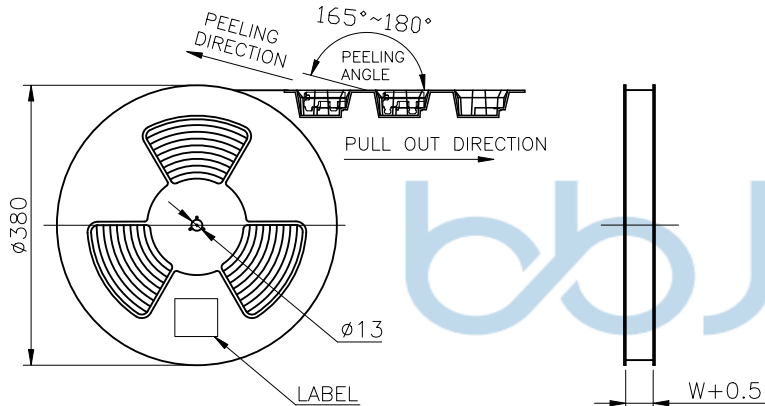
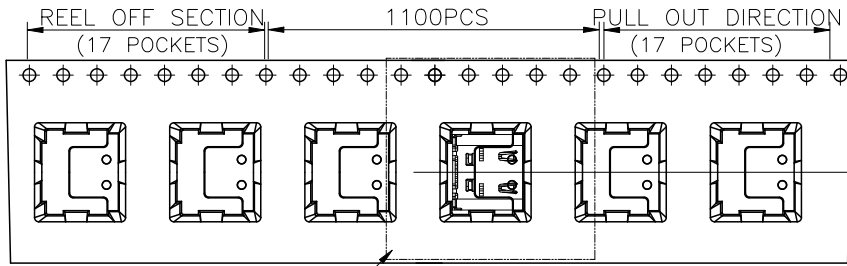

THIS DOCUMENT IS THE SOLE PROPERTY OF BBJconn Technology Co.,Ltd. Corporation AND SHOULD NOT BE USED IN WHOLE OR IN PART WITHOUT PRIOR WRITTEN PERMISSION.		深圳市步步精科技有限公司 APPROVED 工程部	
PDWG.NO: 0900-1	DR.	SGF	NAME: TYPE-C 24P 母座 双排SMT 板上四脚DIP 脚距8.64 带柱 带弹 L=8.17 CH=1.60 编带 PJ. NO.: 126-221-240004-J8G SIZE: A4 DRW NO.: FINISH: SEE NOTES MAT'L.: SEE NOTES SCALE: N/A REV.: A0 UNIT: mm PAGE: 3/3