

REV.	ECN NO.	CONTENT	DATE	ENGINEER
A0		Initial release	/	TSP

NOTES:
 1.Contact Resistance:40m Ω Max for initial;
 2.Dielectric Withstanding Voltage:100V AC For 1 Minute;
 3.Insulation Resistance:100M OHM Min.;
 4.Mating And Unmating Force:
 Mating Force: 5~20N
 Unmating Force: 8~20N;
 6~20N AFTER TEST;
 5.Durability:10000 Cycles;

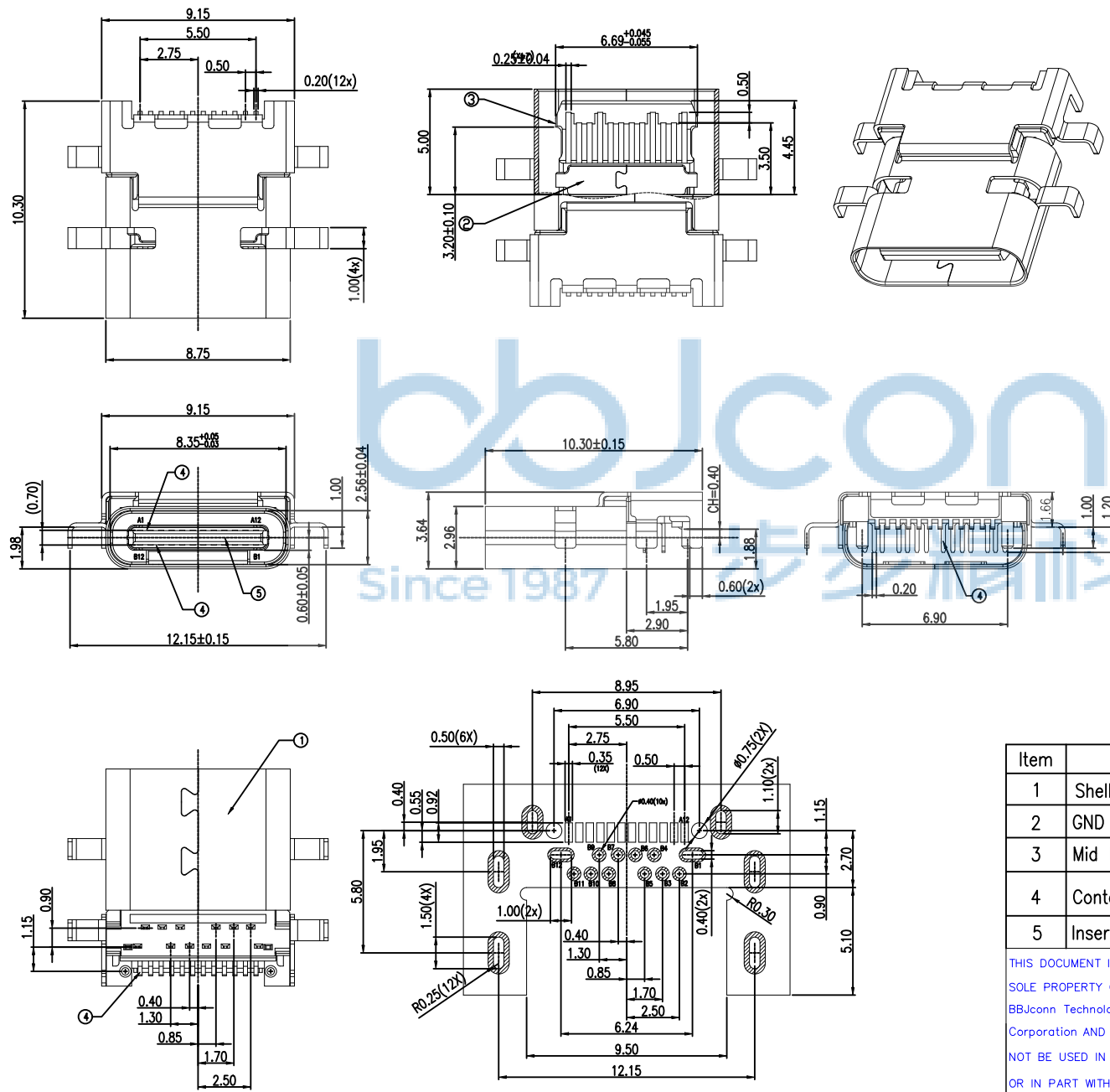

USB TYPE-C PIN ASSIGNMENTS

PIN NUMBER	SIGNAL NAME	PIN NUMBER	SIGNAL NAME
A1	GND	B12	GND
A2	SSTXp1	B11	SSRXp1
A3	SSTXn1	B10	SSRXn1
A4	Vbus	B9	Vbus
A5	CC1	B8	SBU2
A6	Dp1	B7	Dn2
A7	Dn1	B6	Dp2
A8	SBU1	B5	CC2
A9	Vbus	B4	Vbus
A10	SSRXn2	B3	SSTXn2
A11	SSRXp2	B2	SSTXp2
A12	GND	B1	GND

Item	Title	Material	Dispose	Q'TY
1	Shell	SUS304	Ni:50u" Min.	1PCS
2	GND Plate	SUS304	Ni:50u" Min.	1PCS
3	Mid Plate	SUS301	Ni:50u" Min.Tin:80u" Min	1PCS
4	Contact	C7025	Mating Area: AU G/F,Tin:100u" Min Solder Tails: NI 50u" MIN	2PCS
5	InsertMolding	LCP	UL 94V-0 Black	1PCS

THIS DOCUMENT IS THE SOLE PROPERTY OF BBJconn Technology Co.,Ltd. Corporation AND SHOULD NOT BE USED IN WHOLE OR IN PART WITHOUT PRIOR WRITTEN PERMISSION.

PDWG:NO: 0900-1

深圳市步步精科技有限公司

NAME: TYPE-C 24P 母座 沉板1.88 SMT+DIP
六脚插 带柱 L=10.30 CH=0.40

APPD. JM_Zheng
CHKD. LYX
DR. TSP

PJ. NO.: 126-223-240003-J8G
SIZE: A4 DRW NO.:
FINISH: SEE NOTES MAT'L.: SEE NOTES
SCALE: N/A REV.: A0 UNIT: mm PAGE: 1/2

PCB LAYOUT (RECOMMENDED)
(Tol:±0.05)

REV.	ECN NO.	CONTENT	DATE	ENGINEER
A0		Initial release	/	TSP

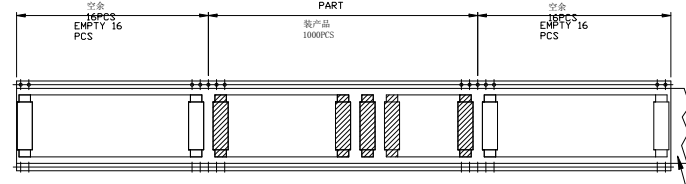
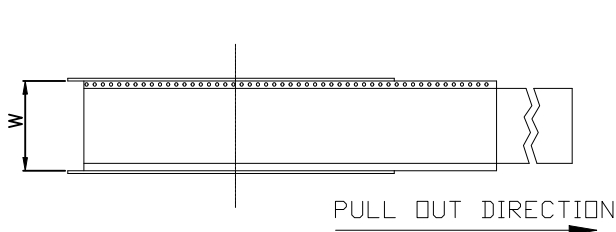

ITEM 項目	PARTS NAME 零件名稱	FINISH/REMARK 處理/備註
1	CONNECTOR	10000 PCS/BOX
2	BOX	10 REEL/BOX
3	WATERPROOF BAG	1 PCS
4	REEL	1000 PCS/REEL
5	COVER TAPE	Wide=24mm
6	CARRIER TAPE	--
7	LABEL	批號標籤

TOP COVER TAPE

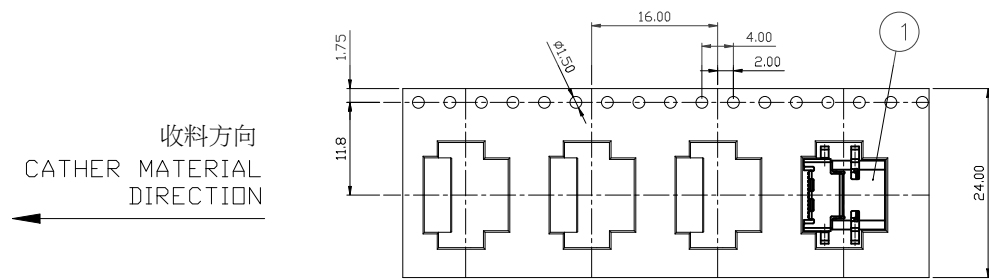
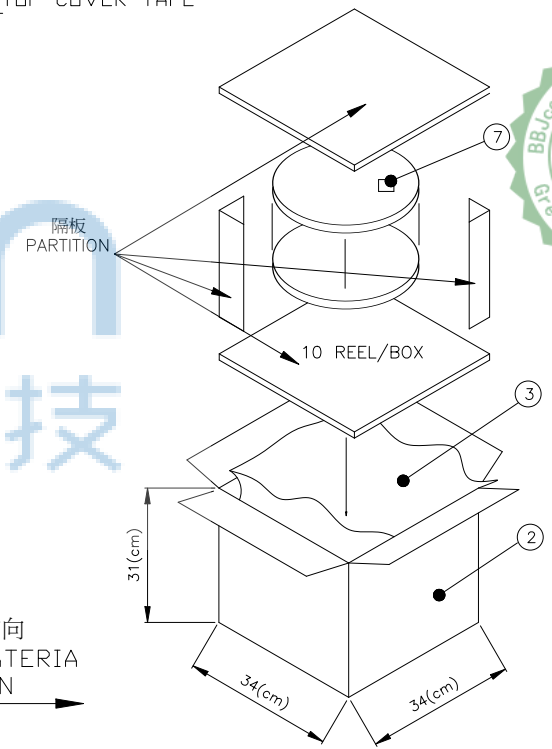
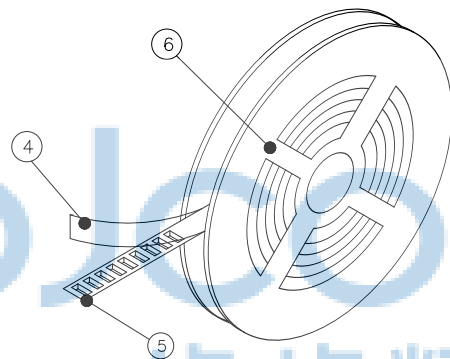
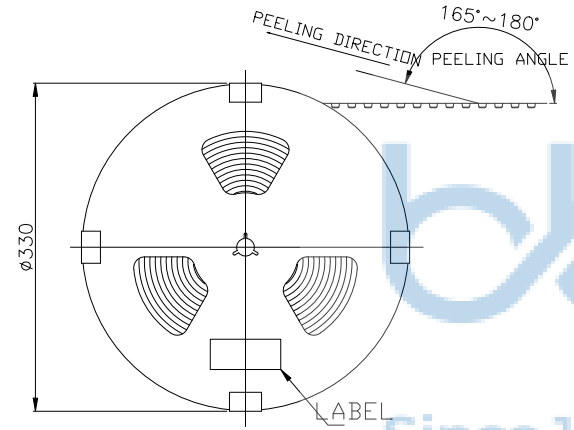

客戶放料方向 INPUT MATERIA DIRECTION

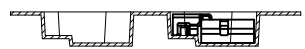

TAPE REEL成品擺放方向

NOTES
1.MATERIAL: PS (Color: 透明)
2.DEFORMATION(變形)&DAMAGE(損壞): NA.(不可)



THIS DOCUMENT IS THE SOLE PROPERTY OF BBJconn Technology Co.,Ltd. Corporation AND SHOULD NOT BE USED IN WHOLE OR IN PART WITHOUT PRIOR WRITTEN PERMISSION.		深圳市步步精科技有限公司	
.X: ±0.38 .XX: ±0.25 .XXX: ±0.13		NAME: TYPE-C 24P 母座 沉板 1.88 SMT+DIP 六脚插 带柱 L=10.30 CH=0.40	
X': ±3' .X': ±2' .XX': ±1'		PJ. NO.: 126-223-240003-J8G	
APPD. JM_Zheng	CHKD. LYX	SIZE: A4 DRW NO.:	
PDWG.NO: 0900-1	DR. TSP	FINISH: SEE NOTES MAT'L.: SEE NOTES	
		SCALE: N/A	REV.: A0 UNIT: mm PAGE: 2/2