

REV.	ECN NO	CONTENT	DATE	ENGINEER
A0		Initial release	/	LYL

NOTES:
 1.MATERIAL :SEE TABLE
 2.COPLANARITY : 0.10 Max.
 3.ELECTRICAL CHARACTERISTICS
 LOW LEVEL CONTACT RESISTANCE: 40mΩ Max
 INSULATION RESISTANCE:100MΩ MIN
 DIELECTRIC WITHSTANDING VOLTAGE:100 VAC:
 CONTACT CURRENT RATING:5A Max
 4.MECHANICAL CHARACTERISTICS
 INSERTION FORCE: 5~20N
 EXTRACTION FORCE: 8~20N
 AFTER DURABILITY EXTRACTION FORCE: 6~20N
 5.DURABILITY: 10000 CYCLES
 6.PACKAGING TYPE: CARRIER TAPE.
 7.SALT SPRAY : 24 HOURS

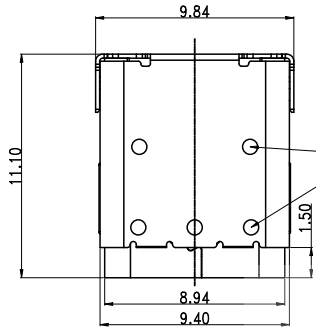

Spot welding position is only for your reference

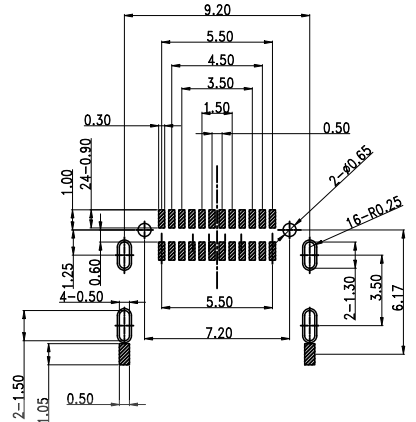

RECOMMENDED P.C.B LAYOUT (COMPONENT SIDE)
PCB THICKNESS: 2.0±0.05mm

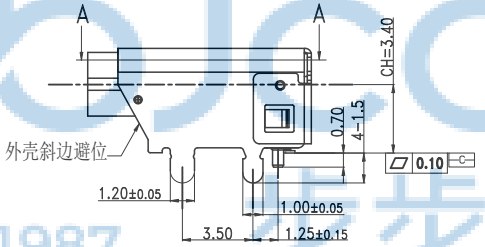
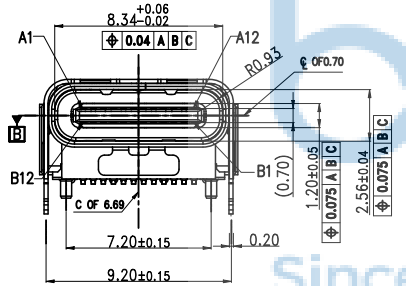

外壳斜边避让

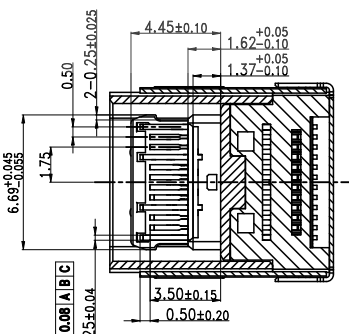
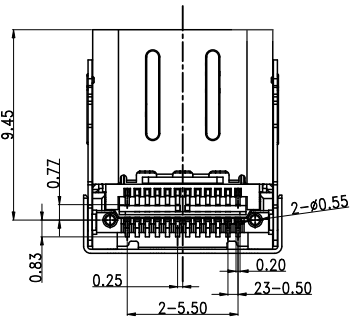

SECTION A-A

6	OUTER-SHELL	1	SUS304	SOLDER NICKEL: 50U" MIN
5	INNER-SHELL	1	SUS304	SOLDER NICKEL: 50U" MIN
4	TOP TERMINAL	1	C7025	MATING AREA:AU 3u" SOLDER TAIL:MATTE TIN 100 MIN, 50u" NICKEL OVERALL.
3	BOTTOM TERMINAL	1	C7025	MATING AREA:AU 3u" SOLDER TAIL:MATTE TIN 100 MIN, 50u" NICKEL OVERALL.
2	MID PLATE	1	SUS301	NO PLATING
1	MAIN HOUSING	1	HIGH TEMPERATURE	ICP,BLACK
ITEM	DESCRIPTION	Q'TY	MATERIAL	FINISH

BILL OF MATERIAL

Pin No	Signal Name	Mating Sequence	Pin No	Signal Name	Mating Sequence
A1	GND	First	B12	GND	First
A2	TX1+	Second	B11	RX1+	Second
A3	TX1-	Second	B10	RX1-	Second
A4	Vbus	First	B9	Vbus	First
A5	CC1	Second	B8	SBU2	Second
A6	D+	Second	B7	D-	Second
A7	D-	Second	B6	D+	Second
A8	SBU1	Second	B5	CC2	Second
A9	Vbus	First	B4	Vbus	First
A10	RX2-	Second	B3	TX2-	Second
A11	RX2+	Second	B2	TX2+	Second
A12	GND	First	B1	GND	First

THIS DOCUMENT IS THE SOLE PROPERTY OF BBJconn Technology Co., Ltd. Corporation AND SHOULD NOT BE USED IN WHOLE OR IN PART WITHOUT PRIOR WRITTEN PERMISSION.
PDWG:NO: 0900-1

深圳市步步精科技有限公司

NAME: TYPE C 24P 母座 双壳 垫高型 H1.50 CH=3.40 PH3.50 L=11.10 双排SMT 后盖缺口 外壳斜边避让 四脚插 带柱 不短路款 LCP黑色HF 半金雾锡3u

PJ. NO.: 126-221-240022-J8G
 SIZE: A4 | DRW NO.:
 FINISH: SEE NOTES | MAT'L.: SEE NOTES
 SCALE: N/A | REV.: A0 | UNIT: mm | PAGE: 1/2





REV.	ECN NO	CONTENT	DATE	ENGINEER
A0		Initial release	/	LYL

出料方向
PULL OUT DIRETEON

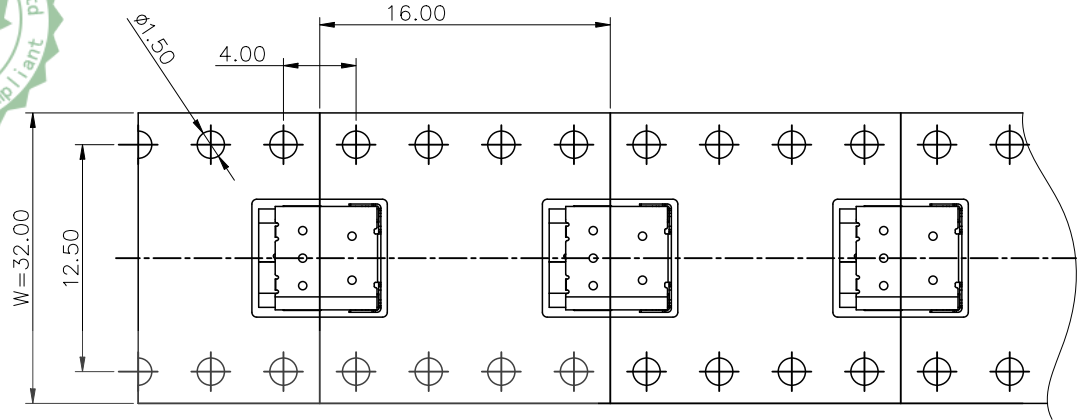
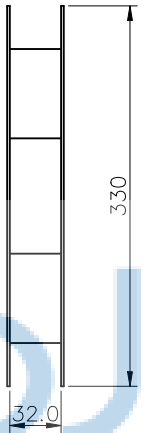
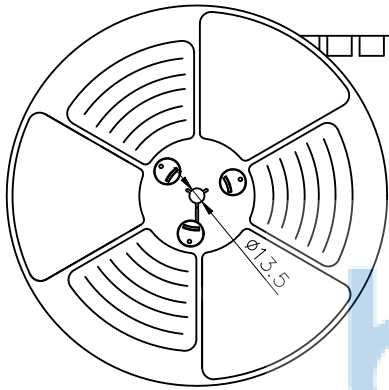

出料方向
PULL OUT DIRETEON

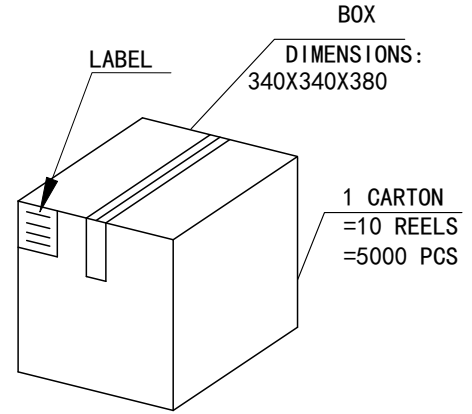
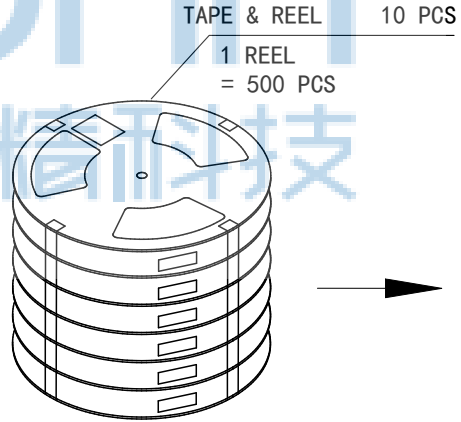
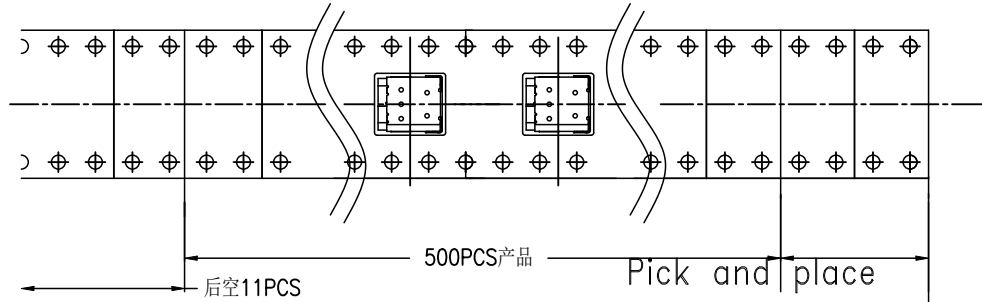

前空11PCS

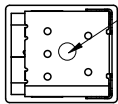

THIS DOCUMENT IS THE SOLE PROPERTY OF BBJconn Technology Co.,Ltd. Corporation AND SHOULD NOT BE USED IN WHOLE OR IN PART WITHOUT PRIOR WRITTEN PERMISSION.		深圳市步步精科技有限公司	
PDWG:NO: 0900-1	DR. LYL	.X: ±0.38 .XX: ±0.25 .XXX: ±0.13 X': ±3" .X': ±2" .XX': ±1"	NAME: TYPE C 24P 母座 双壳 垫高型 H1.50 CH=3.40 PH3.50 L=11.10 双排SMT 后盖缺口 外壳斜边避位 四脚插 带柱 不短路款 LCP黑色HF 半金雾锡3u
APPD. JM_Zheng	CHKD. LYX	PJ. NO.: 126-221-240022-J8G	SIZE: A4 DRW NO.:
		FINISH: SEE NOTES	MAT'L.: SEE NOTES
		SCALE: N/A	REV.: A0 UNIT: mm PAGE: 2/2