



REV	ECN NO	CONTENT	DATE	ENGINEER
A0		INITIAL RELEASE	/	SGF

NOTE:

1.MATERIAL:

- 1.1 HOUSING: LCP, UL 94V-0, COLOR- BLUE (PANTONE 300C) OR BLACK
- 1.2 BOTTOM COVER: LCP, UL 94V-0,COLOR- BLUE (PANTONE 300C) OR BLACK
- 1.3 CONTACT: C7025(T=0.12mm);C2680(T=0.15mm)
- 1.4 SOCKET SHELL: SUS304-1/2H(T=0.3mm)
- 1.5 FRONT MIDDLE SHELL:SUS304-1/2H(T=0.25mm)
- 1.6 REAR SHELL:SUS304-1/2H(T=0.2mm)
- 1.7 MID PLATE:SUS301-1/2H(T=0.15mm)
- 1.8 PCB: FR4

2.ELECTRICAL CHARACTERISTICS;

- 2.1 CONTACT RESISTANCE: 30mΩ Max FOR INITIAL. 10mΩ CHANGE AFTER TEST. MEASURE AT 20mV, 100mA.
- 2.2 CONTACT CURRENT RATING: 5A FOR COLLECTIVELY POWER SUPPLY PIN(PINA1,A4,A9,A12,B1,B4,B9,B12); 1.25A FOR VCONN PIN; 0.25A FOR OTHER SIGNAL PIN.
- 2.3 DIELECTRIC WITHSTANDING VOLTAGE: 100V AC R.M.S.
- 2.4 INSULATION RESISTANCE 100MΩ Min
- 2.5 OPERATING TEMPERATURE: -40°C ~ 85°C

3 MECHANICAL CHARACTERISTICS:

- 3.1 MATING FORCE: 5~20 N.
- 3.2 UNMATED FORCE: 8~20N INITIAL TEST; 6~20N DURABILITY AFTER TEST
- 3.3 DURABILITY: 10,000 CYCLES

4.PLATING

- 4.1 TERMINAL CONTACT: 1u" GOLD PLATING ON CONTACT AREA, ALL OVER 50u" Min NICKEL AND 1u"Min Matte GOLD ALL OVER 50u" Min NICKEL ON SOLDER AREA
- 4.2 SHELL: 50u" Min. NICKEL ALL OVER,
- 4.3 MID PLATE: CLEAN

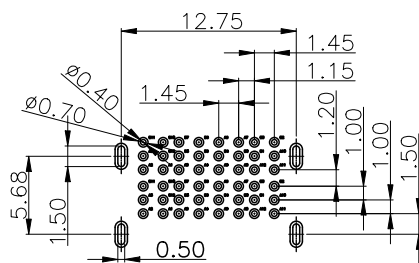
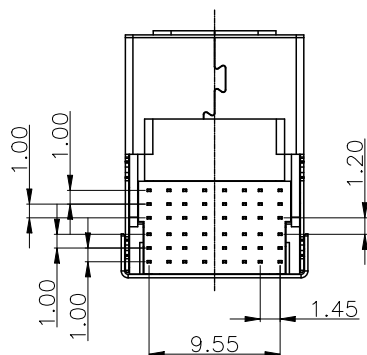
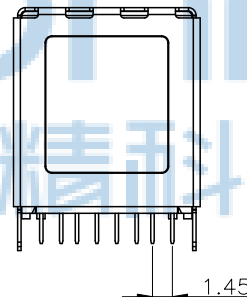
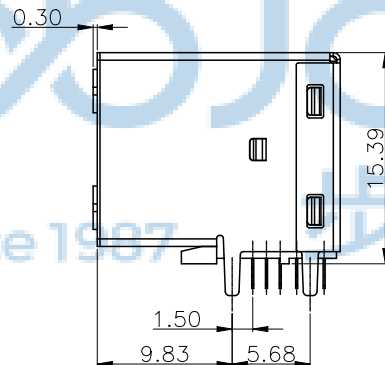
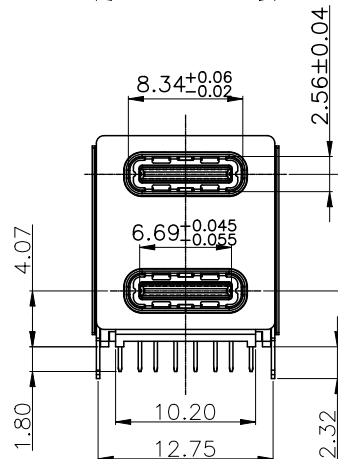
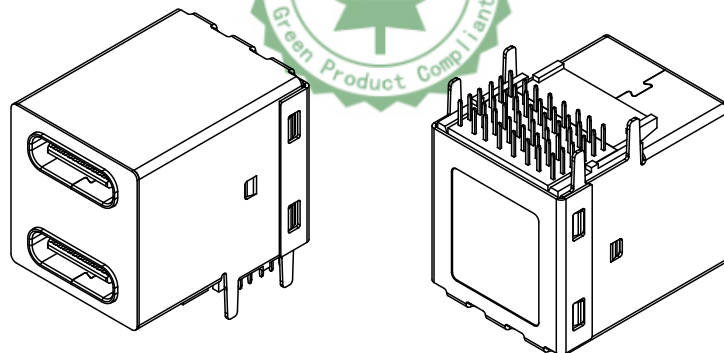
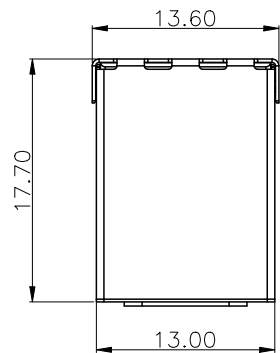

RECOMMENDED PCB LAYOUT(TOP VIEW)  
(DEFAULT TOLERANCE:±0.05)



USB TYPE-C PIN ASSIGNMENTS

PIN NUMBER	SIGNAL NAME	PIN NUMBER	SIGNAL NAME
A1	GND	B12	GND
A2	SSTxp1	B11	SSRXp1
A3	SSTxn1	B10	SSRXn1
A4	Vbus	B9	Vbus
A5	CC1	B8	SBU2
A6	Dp1	B7	Dn2
A7	Dn1	B6	Dp2
A8	SBU1	B5	CC2
A9	Vbus	B4	Vbus
A10	SSRXn2	B3	SSTxn2
A11	SSRXp2	B2	SSTxp2
A12	GND	B1	GND

THIS DOCUMENT IS THE  
SOLE PROPERTY OF  
BBJconn Technology Co.,Ltd.  
Corporation AND SHOULD  
NOT BE USED IN WHOLE  
PRIOR WRITTEN PERMISSION.  
PDWG NO: 0900-1

**bbJconn** 深圳市步步精科技有限公司  
APPROVED 工程部

NAME:TYPE-C 24P 母座 双层 L=17.70 H=15.40 CH=4.07 四脚插 端子DIP 带后盖 不锈钢外壳 LCP蓝胶 盒装	
APPD	JM_Zheng
CHKD	LYX
DR	SGF
PJ NO: 126-221-240024-J8G	
SIZE:A4 DRW NO:	
FINISH:SEE NOTES	MAT'L:SEE NOTES
SCALE:N/A	REV:A0 UNIT:mm PAGE:1/2

REV	ECN NO	CONTENT	DATE	ENGINEER
AO		INITIAL RELEASE	/	SGF

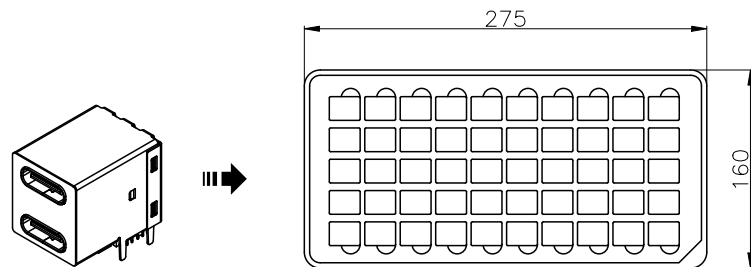

产品

1、将产品整齐摆放脆盘中,共50PCS.

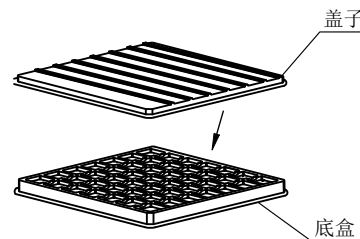

2、装满一盘产品後,将盖子盖上。

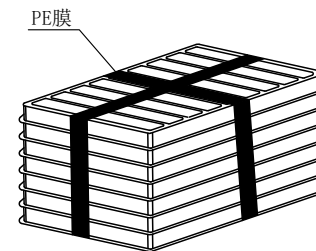

3、将装满产品的脆盘叠放14层;然後用打包膜捆绑(共700PCS)。

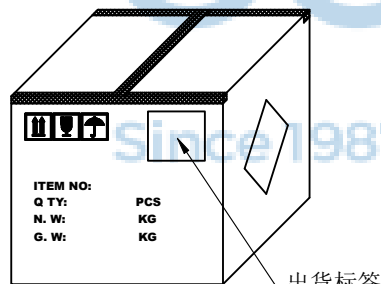

1400PCS/箱

6、用胶纸工字型封住纸箱,一共1400PCS产品。

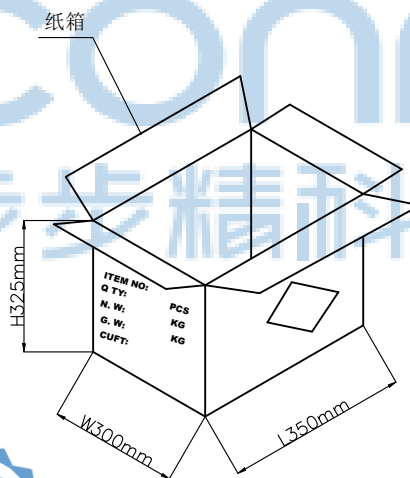

5、将产品2捆并排放入纸箱,上下各放一纸板。

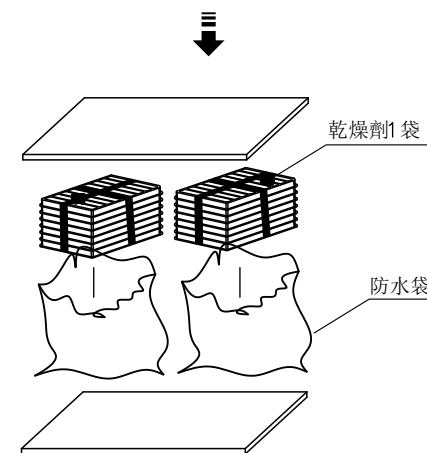

4、将每14层捆绑好的产品装入一个防水袋,加入一袋干燥剂。



作业步骤:

- 1、将产品整齐放入脆盘中,共50PCS,再盖上盖子。
- 2、将装满50PCS产品的脆盘叠放14盘,用打包膜捆绑。
- 3、将捆绑好的产品放入防水袋中,再放入1袋干燥剂,胶带封口(共700PCS)。
- 4、在纸箱底先放一个纸板,然后将捆好的产品并排放入纸箱,顶层再放一个纸板。
- 5、合上纸箱後,再用胶带工字型将纸箱封口,整箱共1400PCS产品。
- 6、贴上出货标签,如有零数箱需做标识。
- 7、纸箱材质尺寸: K=K 350\*300\*325mm (内径)  
脆盘材质尺寸: PS防静电 275\*160\*14.5mm

THIS DOCUMENT IS THE SOLE PROPERTY OF BBJconn Technology Co.,Ltd. Corporation AND SHOULD NOT BE USED IN WHOLE PRIOR WRITTEN PERMISSION.		深圳市步步精科技有限公司 .X: ±0.38 .XX: ±0.25 .XXX: ±0.13 X': ±3' .X': ±2' .XX': ±1'		NAME:TYPE-C 24P 母座 双层 L=17.70 H=15.40 CH=4.07 四脚插 端子DIP 带后盖 不锈钢外壳 LCP蓝胶 盒装	
APPD	JM_Zheng	PJ NO: 126-221-240024-J8G		SIZE:A4 DRW NO:	
CHKD	LYX	FINISH:SEE NOTES		MAT'L:SEE NOTES	
PDWG NO: 0900-1	DR	SGF	SCALE:N/A	REV:AO	UNIT:mm PAGE:2/2