

REV.	ECN NO.	CONTENT	DATE	ENGINEER
A0		Initial release	/	TSP

- NOTES:
- MATERIAL:
 - SHELL: SUS301R-1/2H T=0.20mm
 - SIGNAL: SUS301R-H T=0.10mm
 - RFI PAD: SUS301R-H T=0.08mm
 - HOUSING: PA9T+45%G.F. UL94V-0 BLACK
 - TERMINAL: NKE012R-H T=0.10mm
 - PLATING:
 - TERMINAL: GOLD FLASH ON MATING AREA, MATTE Sn 60u" Min ON SOLDERING AREA, 80u"Min. NICKEL UNDER PLATING OVERALL
 - SHELL: NICKEL PLATED 60u"MIN.
 - ELECTRICAL CHARACTERISTICS:
 - RATING: 20V 5A
 - CONTACT RESISTANCE: 40mΩ MAX
 - DIELECTRIC WITHSTANDING VOTAGE: 100V AC FOR ONE MINUTE
 - INSULATION RESISTANCE: 100MΩ MIN.
 - MECHANICAL CHARACTERISTICS:
 - INSERTION FORCE: 0.5~2.0kgf.(INITIAL)
 - WITHDRAWAL FORCE: 0.8~2.0kgf.(INITIAL) 0.6~2.0kgf.(AFTER LIFE TEST)
 - LIFE TEST: 10,000CYCLES MIN

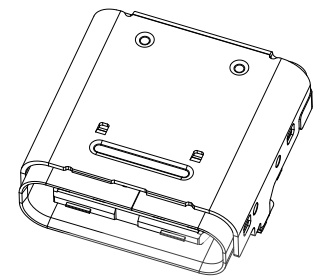

3D VIEW

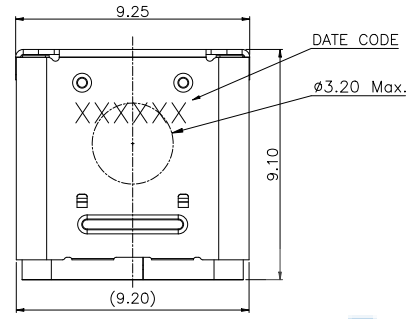
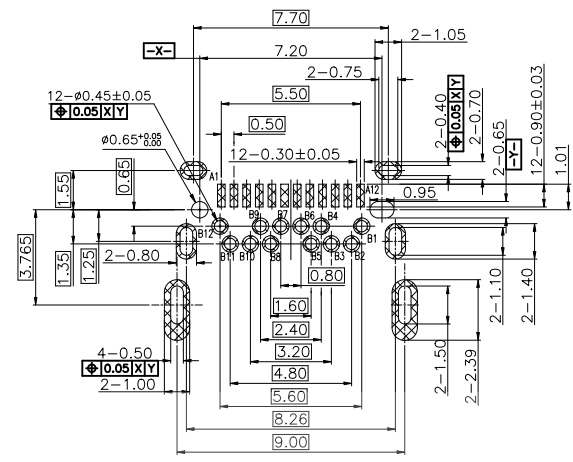

RECOMMENDED PCB LAYOUT(TOP VIEW)
(TOLERANCE=±0.05mm)

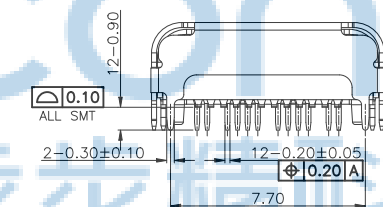
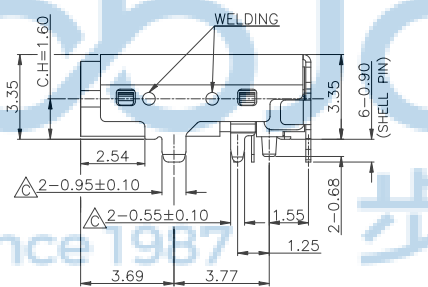
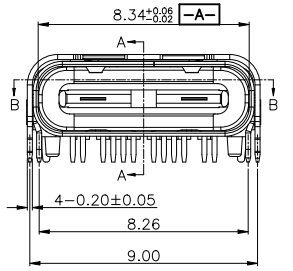

USB TYPE-C PIN ASSIGNMENTS:

A12	GND	B1	GND
A11	SSRXp2	B2	SSTXp2
A10	SSRXn2	B3	SSTXn2
A9	VBUS	B4	VBUS
A8	SBU1	B5	CC2
A7	Dn1	B6	Dp2
A6	Dp1	B7	Dn2
A5	CC1	B8	SBU2
A4	VBUS	B9	VBUS
A3	SSTXn1	B10	SSRXn1
A2	SSTXp1	B11	SSRXp1
A1	GND	B12	GND
PIN	SIGNAL NAME	PIN	SIGNAL NAME

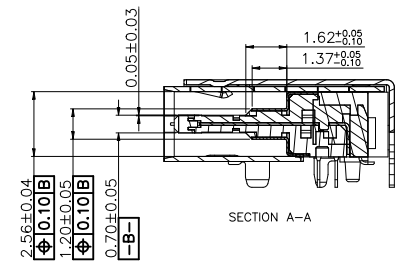
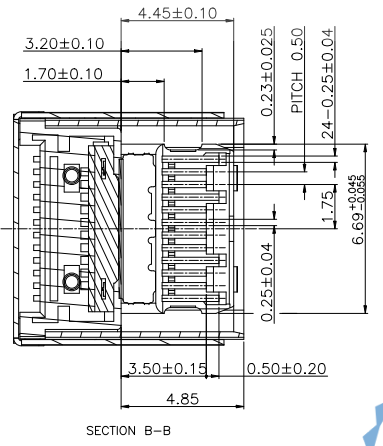
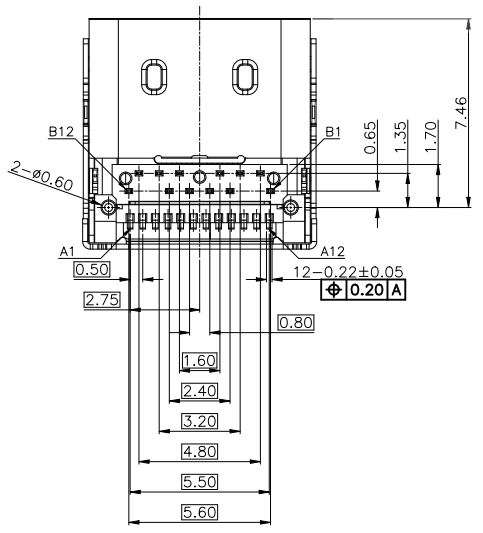

SECTION A-A

SECTION B-B



THIS DOCUMENT IS THE SOLE PROPERTY OF **深圳市步步精科技有限公司** (BBJconn Technology Co., Ltd.)

Corporation AND SHOULD NOT BE USED IN WHOLE OR IN PART WITHOUT PRIOR WRITTEN PERMISSION.

PDWG.NO: 0470-1

NAME: TYPE-C 24P 母座 双壳 SMT+DIP 板上六脚插 带柱 L=9.10 CH=1.60

APPD. JM_Zheng

CHKD. LYX

DR. TSP

PJ. NO.: 126-223-240012-U4G

SIZE: A4 DRW NO.:

FINISH: SEE NOTES MAT'L.: SEE NOTES

SCALE: N/A REV.: A0 UNIT: mm PAGE: 1/2

REV.	ECN NO	CONTENT	DATE	ENGINEER
A0		Initial release	/	TSP

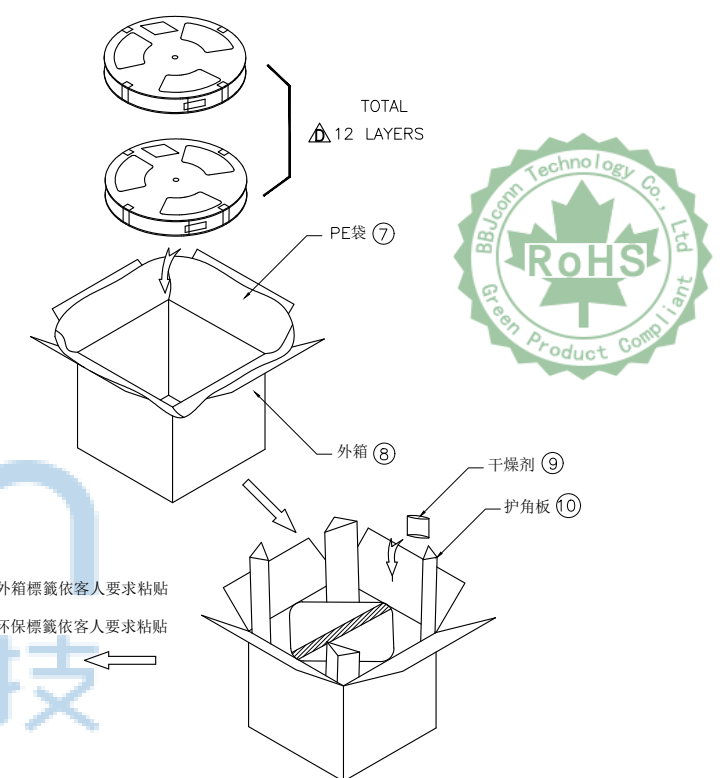
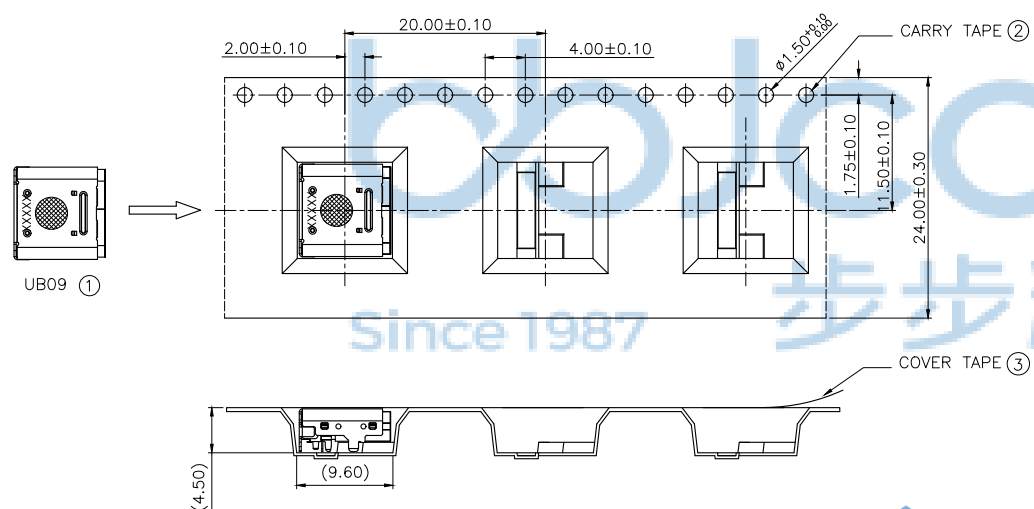
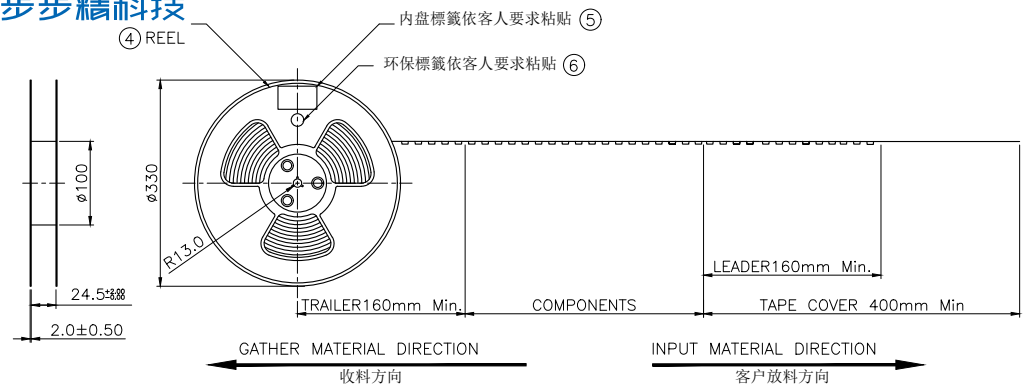

- Notes:
1. 每卷卷带的开始端留160mm以上空格不装产品 (参考值: 30PCS), 以实际包装数量装满后, 结束端预留160mm以上空格不装产品 (参考值: 30PCS)
 2. 卷带用自封胶带封口, 1个卷盘放置800PCS产品;
 3. 再绕一圈保护带, 保护带最后重叠约50mm, 每个卷盘须贴的标签依客人要求粘贴;
 4. 将包好产品及标好标签的卷盘套入真空袋中, 并放1pcs干燥剂, 然后用真空机封口;
 5. 将10盘封好真空袋的卷盘依次放入纸箱中; 外箱外侧以胶带封口(封成“工”字型), 每个外箱外侧标签依客人要求粘贴;
 6. COVER TAPE与CARRY TAPE剥离力: 20g~120g; 剥离角度: 165°~175°; 剥离速度: 250~300mm/min;
 7. 包装数量: 800PCS/REEL, 12REEL/CARTON, 共9600PCS/CARTON;
 8. 符合厂内《环境管理物质管控标准》要求。

项目	品名	规格	数量
①	UC09-10	USB TYPE C	9600PCS
②	CARRY TAPE	W=24mm P=20.0mm L=13.2	12SET
③	COVER TAPE	W=20.7mm	156m
④	REEL	D=φ13" x32mm	12PCS
⑤	物料标签	—	13PCS
⑥	环保标签	—	13PCS
⑦	PE袋	400x500x0.10mm	12PCS
⑧	外箱	350x350x380mm K=K	1PCS
⑨	干燥剂	—	10PCS
⑩	护角板	96X96X365mm (保丽龙)	4PCS

THIS DOCUMENT IS THE SOLE PROPERTY OF BB Jconn Technology Co., Ltd. Corporation AND SHOULD NOT BE USED IN WHOLE OR IN PART WITHOUT PRIOR WRITTEN PERMISSION.

PDWG.NO: 0470-1

DR. TSP

深圳市步步精科技有限公司

NAME: TYPE-C 24P 母座 双壳 SMT+DIP 板上六脚插 带柱 L=9.10 CH=1.60

PJ. NO.: 126-223-240012-U4G

SIZE: A4 DRW NO.:

FINISH: SEE NOTES MAT'L.: SEE NOTES

SCALE: N/A REV.: A0 UNIT: mm PAGE: 2/2