

REV.	ECN NO	CONTENT	DATE	ENGINEER
A0		Initial release	/	TSP

NOTE/注释:

1. SPECIFICATION/规格:

- 1.1 Rated current (额定电流): 5.0 A For Vbus pin
1.25A For Vconn pin
0.25A For Other pin
- 1.2 Voltage rating (额定电压): 5V AC
- 1.3 Contact Resistance (接触阻抗): 40 m Ω Max.
- 1.4 Insulation Resistance (绝缘阻抗): 100MΩ Min.
- 1.5 Withstanding voltage (耐电压): 100 VAC/minute
- 1.6 Mating force (插入力): 5~20N.
- 1.7 Unmating force (拔出力): 8~20N.
- 1.8 Durability Cycle(寿命循环): 10,000 cycle
- 1.9 Operating temperature (工作温度): -40°~+85°

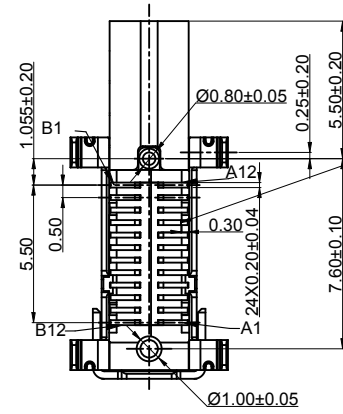
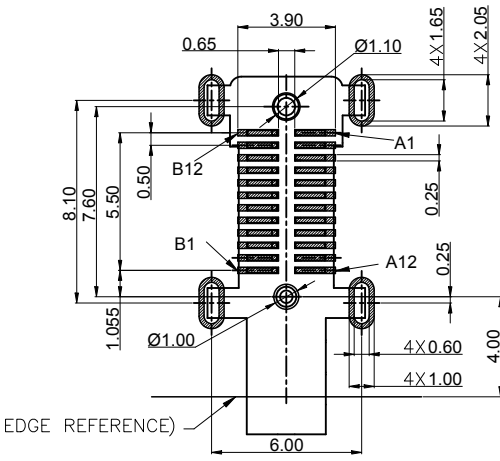
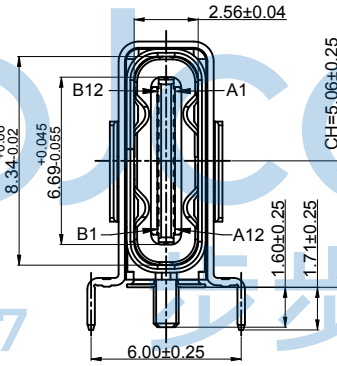
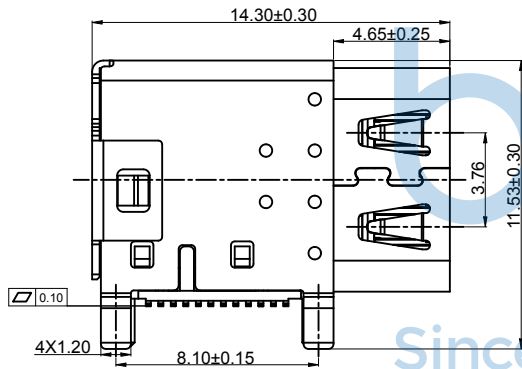
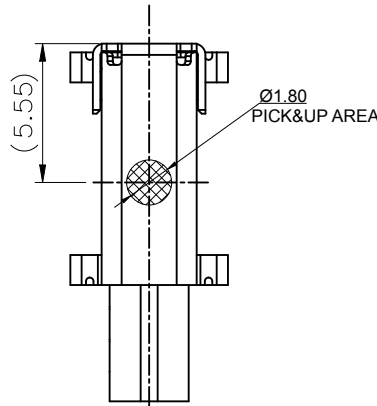
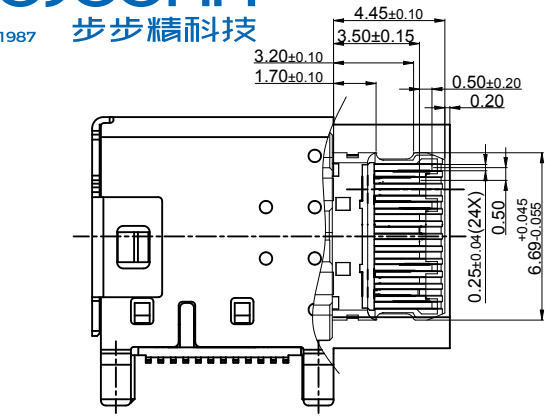

焊接区金G/F
测点位置

PIN ASSIGNMENT

A1	A2	A3	A4	A5	A6	A7	A8	A9	A10	A11	A12
GND	TX1+	TX1-	Vbus	CC1	D+	D-	SBU1	Vbus	RX2-	RX2+	GND
GND	RX1+	RX1-	Vbus	SBU2	D-	D+	CC2	Vbus	TX2-	TX2+	GND
B12	B11	B10	B9	B8	B7	B6	B5	B4	B3	B2	B1

5	TERMINAL	24	COPPER ALLOY (NKE012-EH)	MATING SIDE: SEE TABLE 1 SOLDER TAIL: G/F, 50u" NICKEL OVERALL.	T=0.12
4	OUT SHELL	1	SUS304	50±20u" NICKEL PLATING	T=0.30
3	INNER SHELL	1	SUS304	50±20u" NICKEL PLATING	T=0.30
2	MID PLATE	1	SUS301	30u" NICKEL PLATING	T=0.15
1	MAIN HOUSING	1	HIGH TEMPERATURE	LCP BLACK UL94V-0	
ITEM	DESCRIPTION	QTY	MATERIAL	FINISH	REMARK

BILL OF MATERIAL

THIS DOCUMENT IS THE SOLE PROPERTY OF BBJconn Technology Co., Ltd. Corporation AND SHOULD NOT BE USED IN WHOLE OR IN PART WITHOUT PRIOR WRITTEN PERMISSION.
PDWG.NO: 0470-1

深圳市步步精科技有限公司

NAME: USB 3.2 TYPE-C 24P 母座 侧插 双壳 四脚插 带柱 端子SMT L=14.30 CH=5.06 编带

APPD. JM_Zheng
CHKD. LYX
DR. TSP

PJ. NO.: 126-223-240001-U4G
SIZE: A4 DRW NO.:
FINISH: SEE NOTES MAT'L.: SEE NOTES
SCALE: N/A REV.: A0 UNIT: mm PAGE: 1/2

RECOMMENDED P.C.B LAYOUT
TOLERANCE ± 0.05mm (TOP VIEW)

REV.	ECN NO	CONTENT	DATE	ENGINEER
A0		Initial release	/	TSP

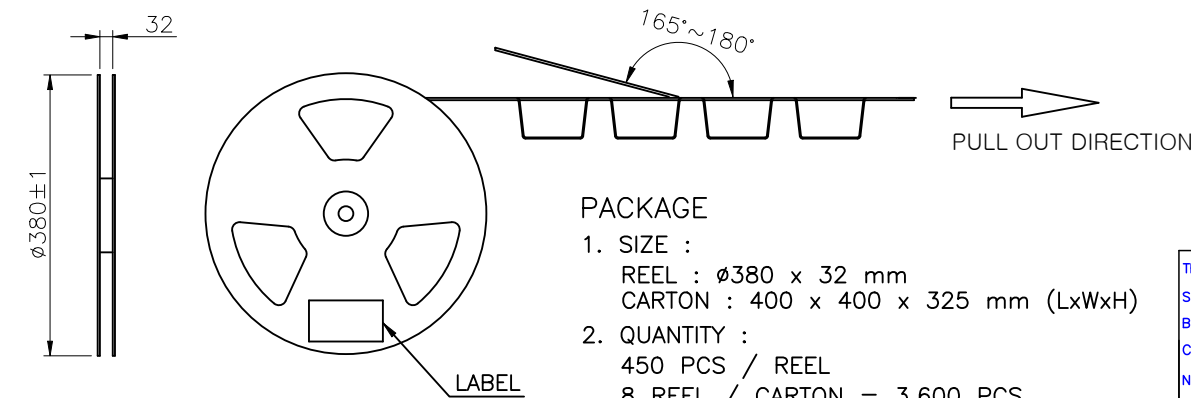
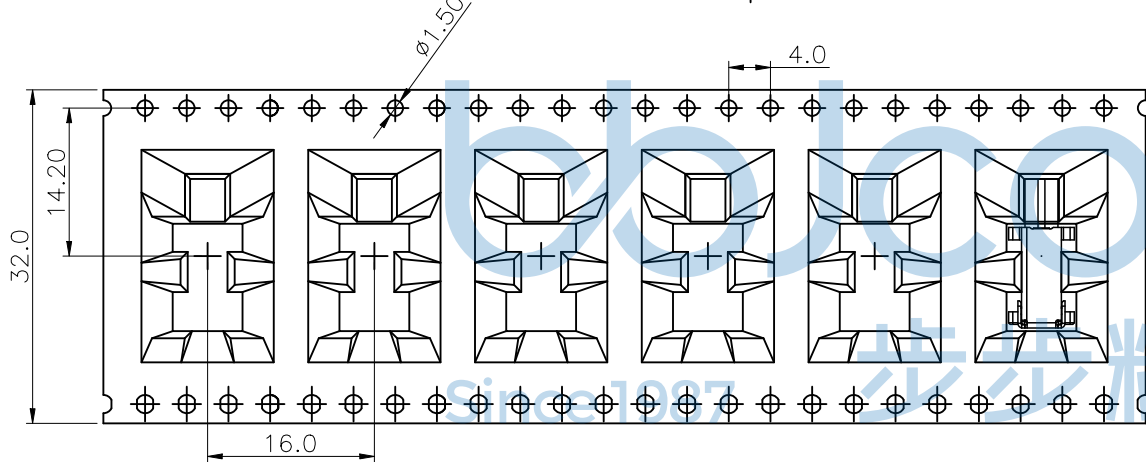
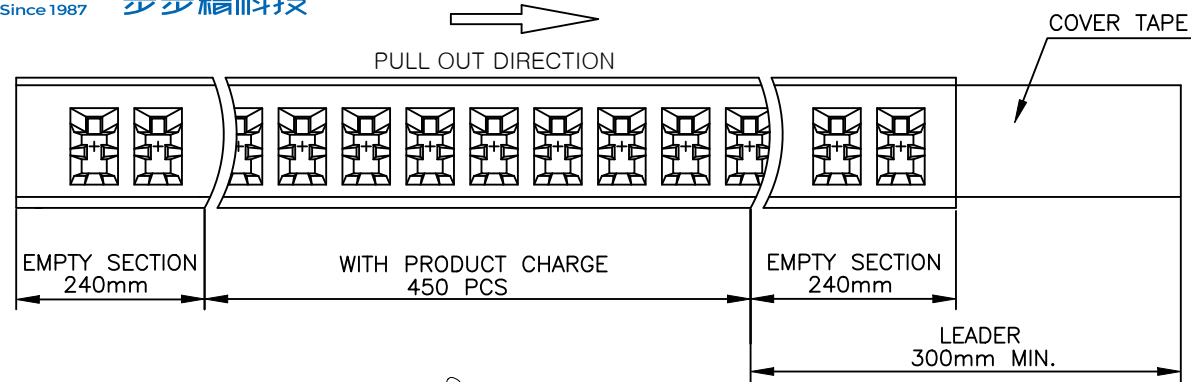

PACKAGE

1. SIZE :
REEL : $\phi 380 \times 32$ mm
CARTON : $400 \times 400 \times 325$ mm (LxWxH)
2. QUANTITY :
450 PCS / REEL
8 REEL / CARTON = 3,600 PCS

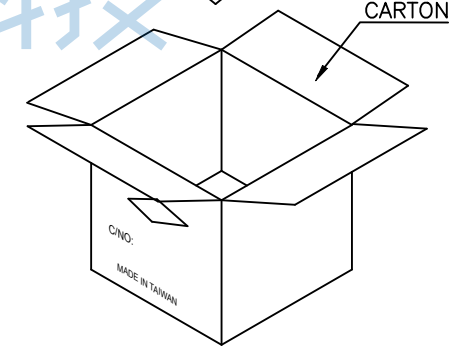
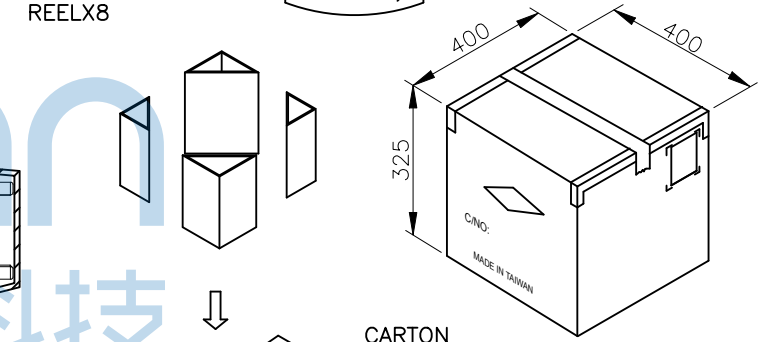
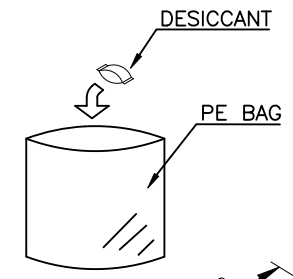
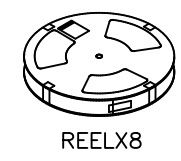

THIS DOCUMENT IS THE SOLE PROPERTY OF BBJconn Technology Co., Ltd. Corporation AND SHOULD NOT BE USED IN WHOLE OR IN PART WITHOUT PRIOR WRITTEN PERMISSION.		深圳市步步精科技有限公司	
PDWG.NO: 0470-1	DR. TSP	.X: ± 0.38 .XX: ± 0.25 .XXX: ± 0.13 X': $\pm 3'$.X': $\pm 2'$.XX': $\pm 1'$	NAME: USB 3.2 TYPE-C 24P 母座 侧插 双壳 四脚插 带柱 端子SMT L=14.30 CH=5.06 编带 PJ. NO.: 126-223-240001-U4G SIZE: A4 DRW NO.: FINISH: SEE NOTES MAT'L.: SEE NOTES SCALE: N/A REV.: A0 UNIT: mm PAGE: 2/2