

REV.	ECN NO	CONTENT	DATE	ENGINEER
A0		Initial release	/	TSP

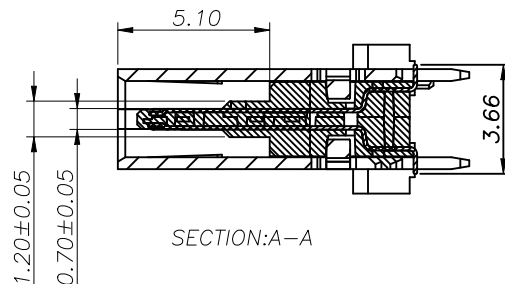
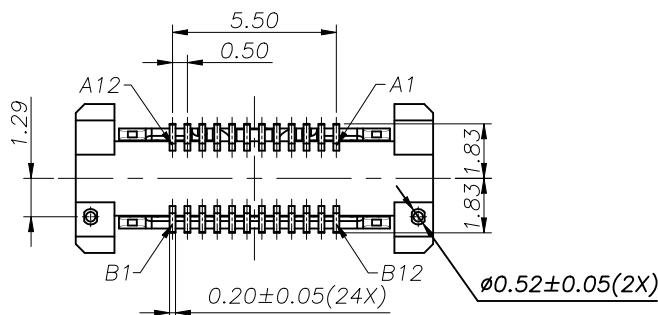
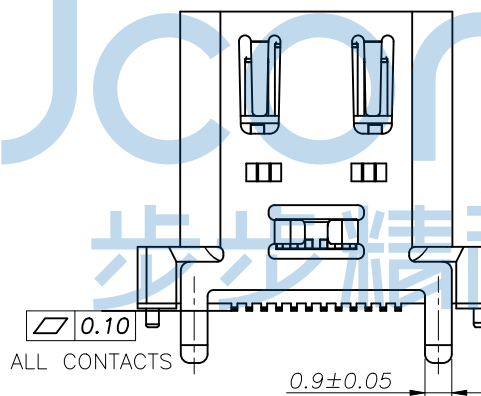
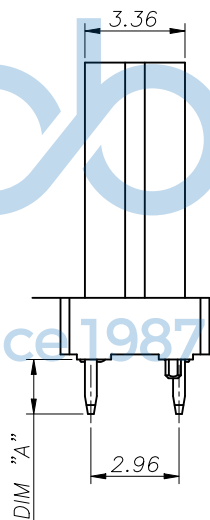
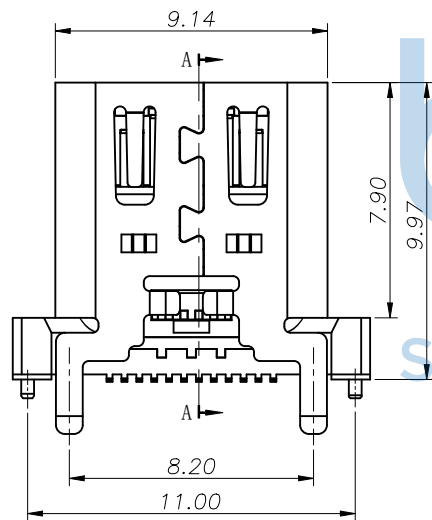
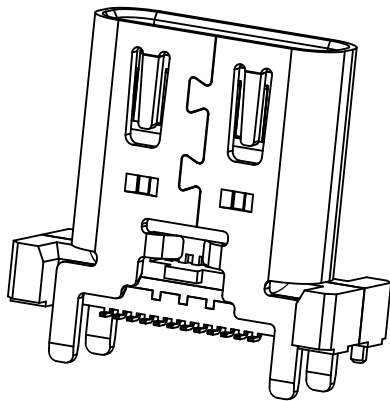
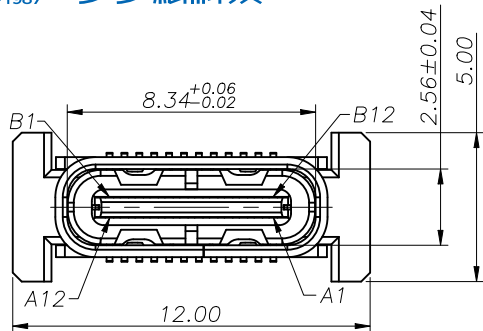

NOTE:

1.MATERIAL SPECIFICATION:

- 1.HOUSING:PA9T, BLACK UL94 V-0.
- 2.TERMINAL: COPPER ALLOY(C18150)
- 3.MID PLATE: STAINLESS STEEL(SUS301)
- 4.FRONT SHELL: STAINLESS STEEL(SUS304)

2.PLATING SPECIFICATION:

- 2-1.TERMINAL:
Ni 50u" MIN. UNDER PLATED OVER ALL.
Au G/F PLATED ON THE FUNCTIONAL AREA OF CONTACT.

- 2-2.SHELL:
Ni 50u" MIN. UNDER PLATED OVER ALL.

- 2-3.MID PLATE:
CLEAR ONLY

3.MECHANICAL PERFORMANCE,

- 3-1.INSERTION FORCE: 0.5~2.0kgf.
- 3-2.REMOVAL FORCE: 0.8kgf~2.0kgf.
- 3-3.DURABILITY: 10000 CYCLES.

4.ELECTRICAL PERFORMANCE,

- 4-1. VOLTAGE RATING:5 V DC/AC (RMS. max)
CURRENT RATING:5 AMPS. FOR TOTAL VBUS/GND PINS;
1.25AMPS FOR CC PIN,0.25 AMPS. FOR ALL OTHER CONTACT.
- 4-2. LLCR:
VBUS & GND PINS AND OTHER PINS: 40mA/PIN MAX.
LLCR MAX. CHANGE OF ALL PINS: 10mA.
- 4-3.INSULATION RESISTANCE: 100MΩ MIN
- 4-4.DIELECTRIC WITHSTAND VOLTAGE,AC 100V FOR 1 MINUTE.

5. ENVIRONMENTAL PERFORMANCE:

- OPERATING TEMPERATURE: -25°C~+85°C.

6.IR REFLOW:

- THE PEAK TEMPERATURE ON THE BOARD SHALL BE MAINTAINED FOR 10 SECONDS AT 260°C.



1.30
1.83
DIM A

THIS DOCUMENT IS THE
SOLE PROPERTY OF
BBJconn Technology Co.,Ltd.
Corporation AND SHOULD
NOT BE USED IN WHOLE
OR IN PART WITHOUT
PRIOR WRITTEN PERMISSION.
PDWG.NO: 0470-1

深圳市步步精科技有限公司

NAME:USB 3.2 TYPE-C 24P 母座 直立式 四脚插 带柱
外壳带弹 外壳脚长1.83 端子SMT H=10.0 编带

APPD. JM_Zheng
CHKD. LYX
DR. TSP

PJ. NO.: UC.01.62-1W-0030
SIZE: A4 DRW NO.:
FINISH: SEE NOTES MAT'L.: SEE NOTES
SCALE: N/A REV.: A0 UNIT: mm PAGE: 1/3

REV.	ECN NO	CONTENT	DATE	ENGINEER
A0		Initial release	/	TSP

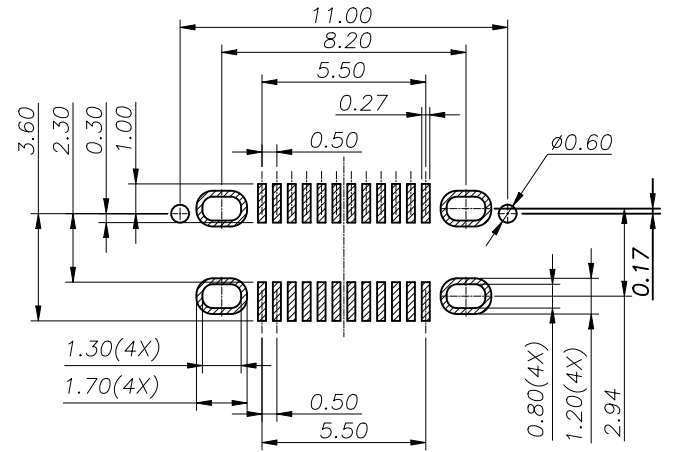
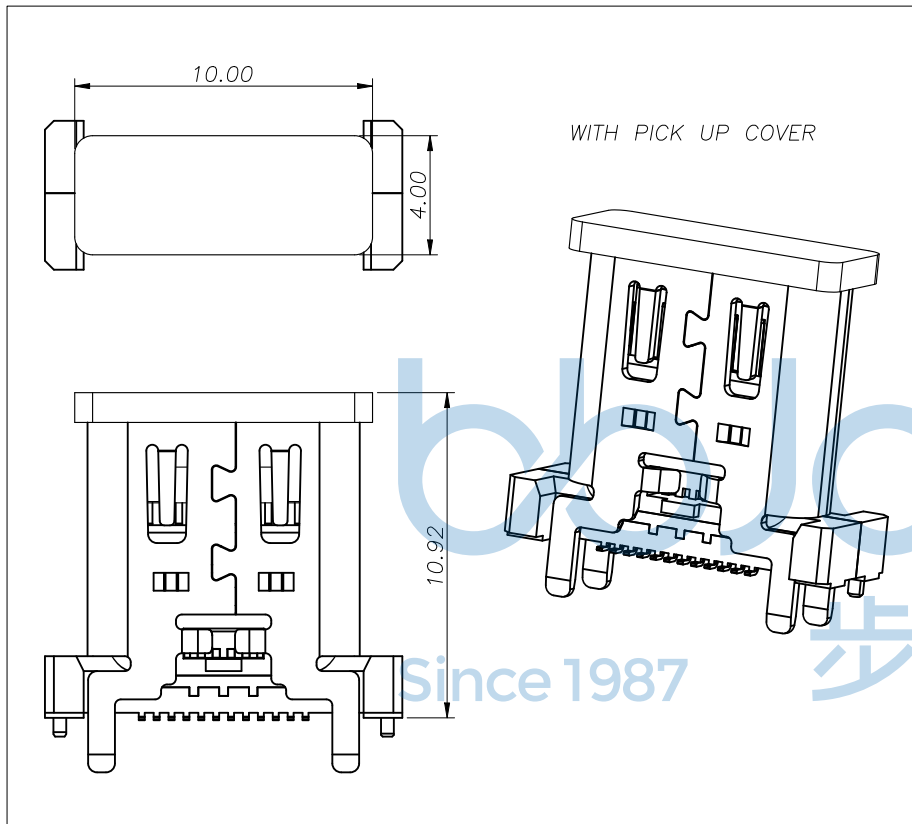

RECOMMENDED PCB LAYOUT(TOP VIEW)
THICKNESS 1.0±0.10MM;DEFAULT TOLERANCE:±0.05

USB TYPE-C PIN ASSIGNMENTS

PIN NUMBER	SIGNAL NAME	PIN NUMBER	SIGNAL NAME
A1	GND	B12	GND
A2	SSTXp1	B11	SSRXp1
A3	SSTXn1	B10	SSRXn1
A4	Vbus	B9	Vbus
A5	CC1	B8	SBU2
A6	Dp1	B7	Dn2
A7	Dn1	B6	Dp2
A8	SBU1	B5	CC2
A9	Vbus	B4	Vbus
A10	SSRXn2	B3	SSTXn2
A11	SSRXp2	B2	SSTXp2
A12	GND	B1	GND



THIS DOCUMENT IS THE SOLE PROPERTY OF BBJconn Technology Co., Ltd. Corporation AND SHOULD NOT BE USED IN WHOLE OR IN PART WITHOUT PRIOR WRITTEN PERMISSION.
PDWG.NO: 0470-1

深圳市步步精科技有限公司

.X: ±0.38 X': ±3'
.XX: ±0.25 .X': ±2'
.XXX: ±0.13 .XX': ±1'

NAME:USB 3.2 TYPE-C 24P 母座 直立式 四脚插 带柱 外壳带弹 外壳脚长1.83 端子SMT H=10.0 编带

APPD. JM_Zheng
CHKD. LYX
DR. TSP

PJ. NO.: UC.01.62-1W-0030
SIZE: A4 DRW NO.:
FINISH: SEE NOTES MAT'L.: SEE NOTES
SCALE: N/A REV.: A0 UNIT: mm PAGE: 2/3

REV.	ECN NO	CONTENT	DATE	ENGINEER
A0		Initial release	/	TSP

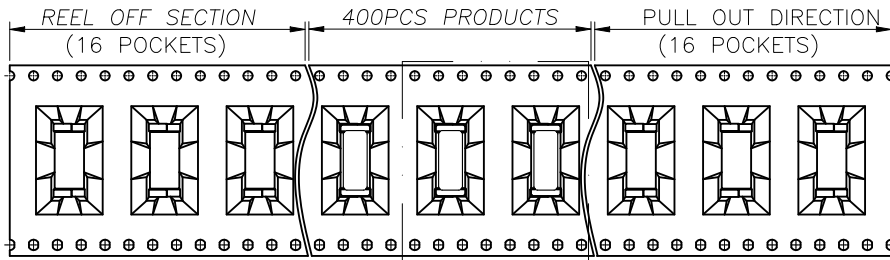

SEE DETAIL X

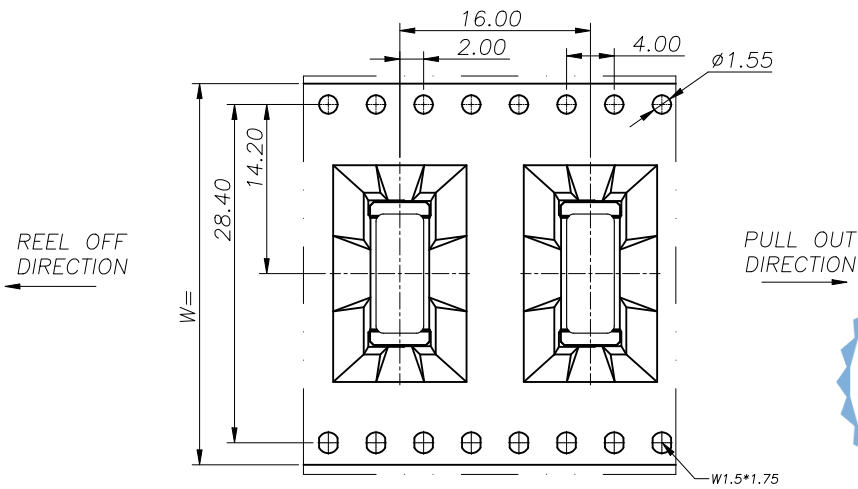
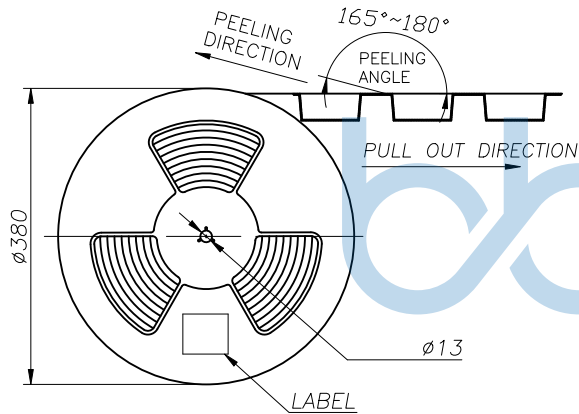

DETAIL X

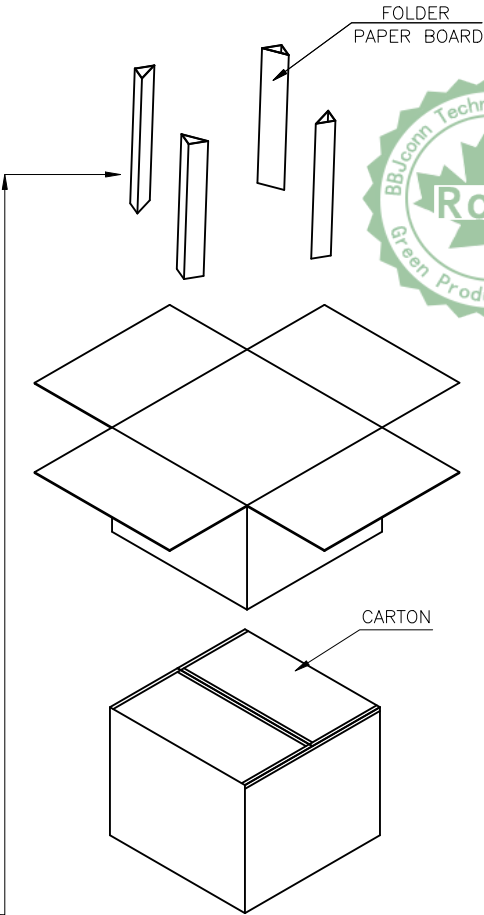
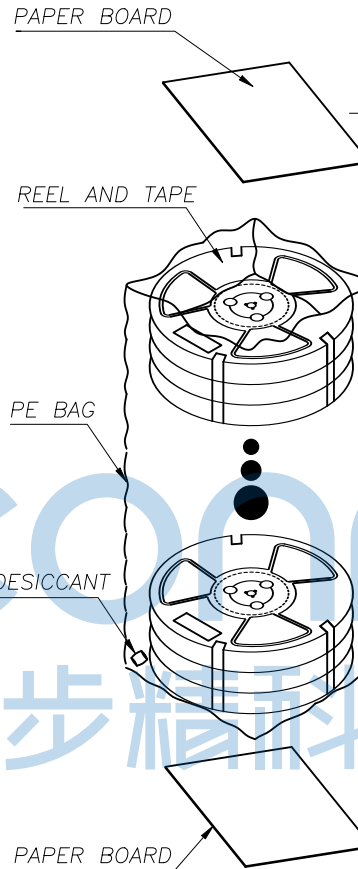

	REEL/TRAY	CARTON
CONNECTOR (PCS)	400	3200



THIS DOCUMENT IS THE SOLE PROPERTY OF BBJconn Technology Co.,Ltd. Corporation AND SHOULD NOT BE USED IN WHOLE OR IN PART WITHOUT PRIOR WRITTEN PERMISSION.		深圳市步步精科技有限公司 NAME: USB 3.2 TYPE-C 24P 母座 直立式 四脚插 带柱 外壳带弹 外壳脚长1.83 端子SMT H=10.0 编带 APPD. JM_Zheng CHKD. LYX DR. TSP PJ. NO.: UC.01.62-1W-0030 SIZE: A4 DRW NO.: FINISH: SEE NOTES MAT'L.: SEE NOTES SCALE: N/A REV.: A0 UNIT: mm PAGE: 3/3	
PDWG.NO: 0470-1			