

| REV. | ECN NO | CONTENT | DATE | ENGINEER |
|------|--------|-----------------|------|----------|
| A0 | | Initial release | / | TSP |

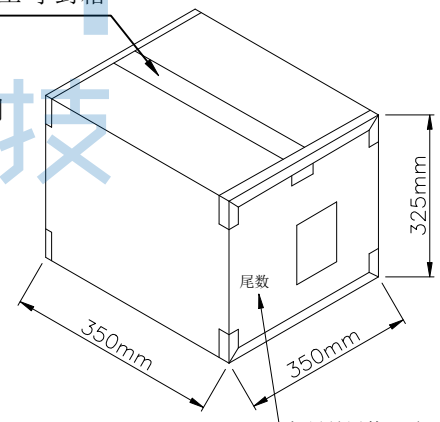
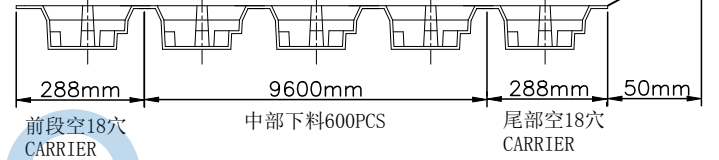
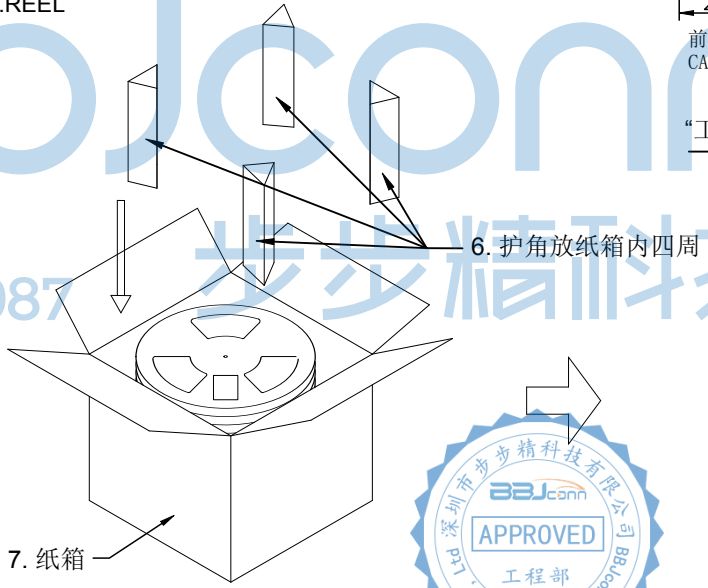
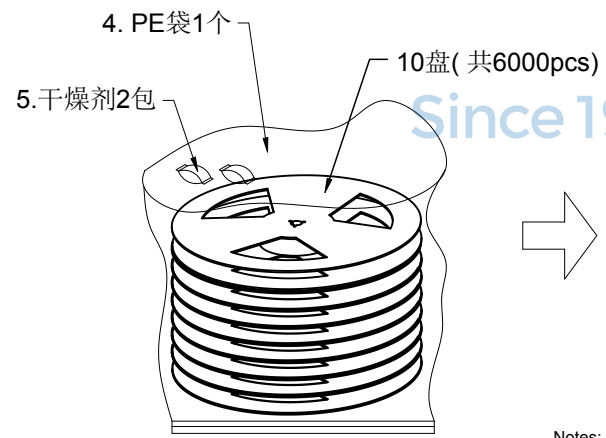
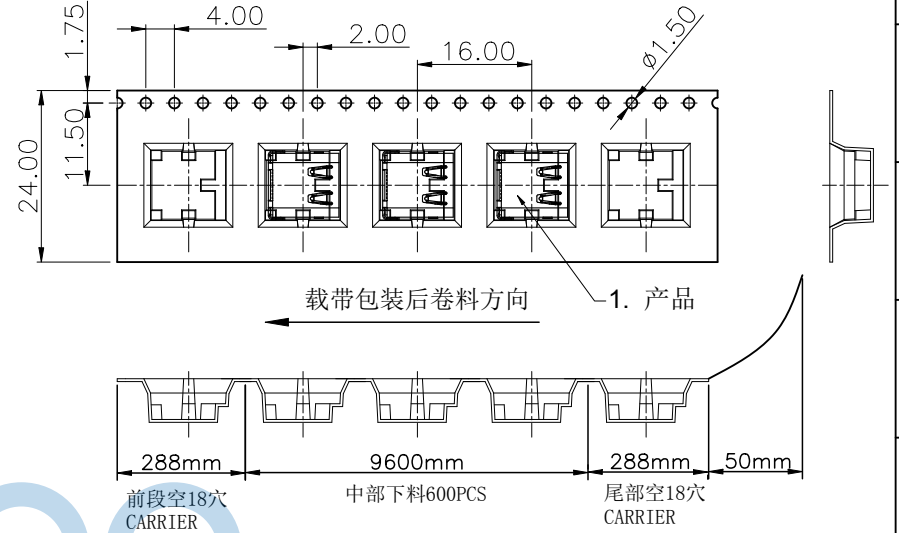
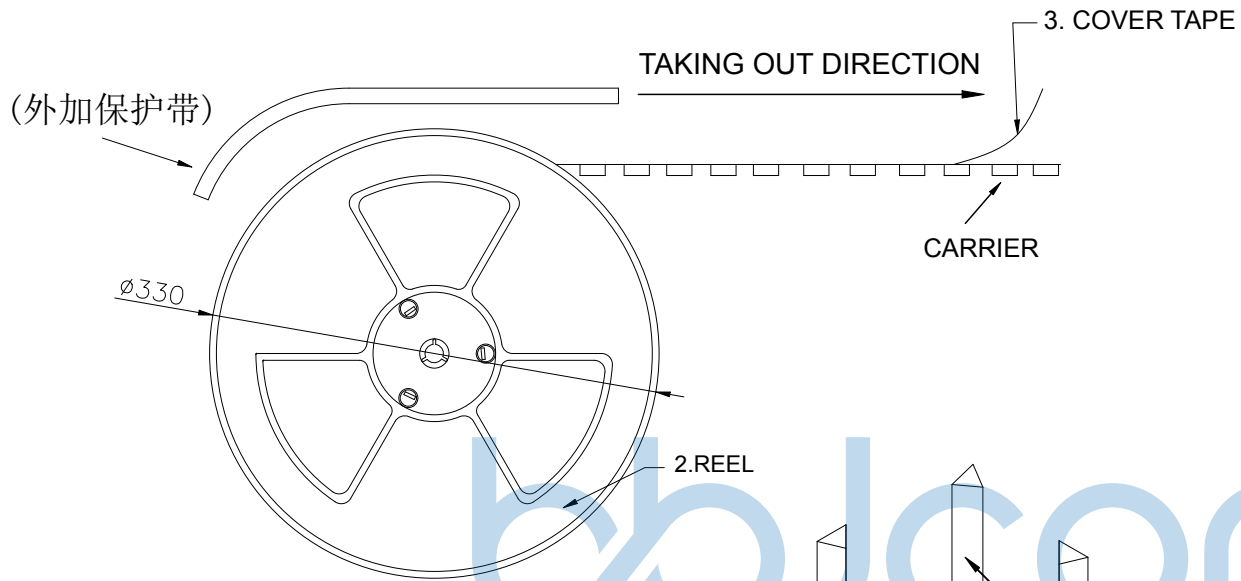

- Notes:**
- 每卷前后各空18PCS.尾部用美纹胶纸封住,
 - 将产品放入载带内,共放600PCS.放满盘后,再卷一圈保护带,保护带最后重叠约50MM,用美纹胶纸将其封住
 - 每10卷盘装入一个防水袋,再放入2包干燥剂,然后放入1个外箱内;纸箱内四周放护角;
 - 在搬运过程中要轻拿轻放.
 - 在运输中不可堆放过多,不可有重压现象.
 - 跌落测试条件:
成品箱子从1.5米高自由落体:(三棱六面一角)检验项目:
1.产品不可跑出下带凹槽.
2.产品不可有摔伤,变形.
3.外箱及内包装材料不可有严重破损.

| 包装数量 | 净重 | 毛重 |
|-----------|----|----|
| 6000Pcs/箱 | | |

| 序号 | 品名 | 规格(mm) | 用量(PCS) |
|----|------------|---------------------|---------|
| 7 | 纸箱 | 双坑K=K 350*350*325mm | 1PCS |
| 6 | 三角柱 | 30.5*29cm | 4PCS |
| 5 | 干燥剂 | ————— | 2PCS |
| 4 | PE袋 | 71*79.5cm | 1PCS |
| 3 | COVER TAPE | 21.0mm (自粘带) | 若干 |
| 2 | REEL | 24.0mm (黑色载带) | 10R |
| 1 | 产品 | ————— | 6K |

THIS DOCUMENT IS THE SOLE PROPERTY OF BBJconn Technology Co., Ltd. Corporation AND SHOULD NOT BE USED IN WHOLE OR IN PART WITHOUT PRIOR WRITTEN PERMISSION.

PDWG. NO: 0470-1 DR. TSP

深圳市步步精科技有限公司

NAME: TYPE-C 24P 母座 有后盖 板上四脚插 带柱 端子SMT+DIP L=9.85 CH=1.72 编带

PJ. NO.: 126-223-240014-U4G

SIZE: A4 DRW NO.:

FINISH: SEE NOTES MAT'L.: SEE NOTES

SCALE: N/A REV.: A0 UNIT: mm PAGE: 2/2