

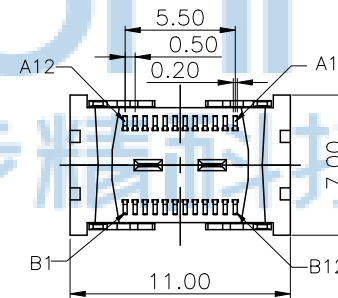

NOTE/注释:

SPECIFICATION/规格:

- 1.1 Rated current (额定电流): 5.0 A Max. for VBus Pins,  
1.25 A for VCONN Pin and GND Pins,  
0.25 A for all of other Pins
- 1.2 Voltage rating (额定电压): 5V AC/DC; 30V AC/DC MAX;
- 1.3 Contact Resistance (接触阻抗): 40 mΩ Max.
- 1.4 Insulation Resistance (绝缘阻抗): 100MΩ Min.
- 1.5 Withstanding voltage (耐电压): 100 V AC for 1 minute
- 1.6 Mating force (插入力): 5~20N .
- 1.7 Unmating force (拔出力): 8~20N.  
6~20N AFTER TEST;
- 1.8 Durability Cycle(寿命循环): 10,000 cycle
- 1.9 Operating temperature (工作温度): -40° ~+85°

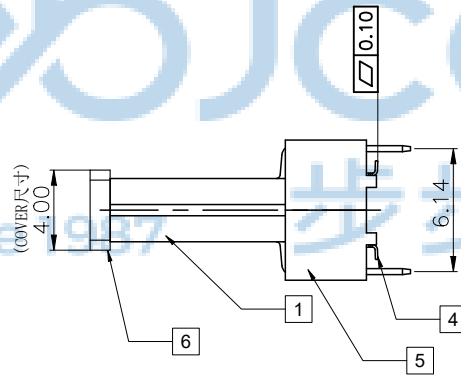
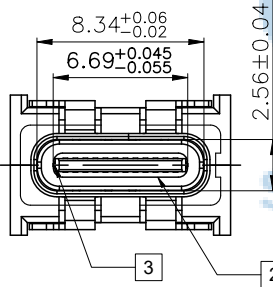
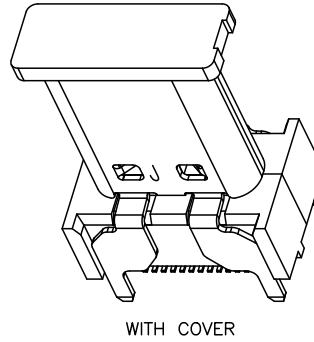
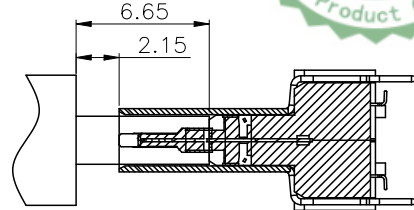
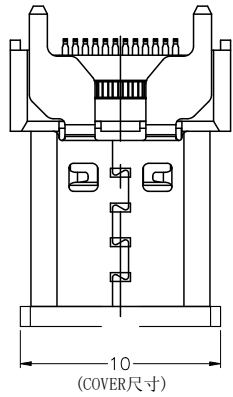

USB TYPE-C PIN ASSIGNMENTS

PIN NUMBER	SIGNAL NAME	PIN NUMBER	SIGNAL NAME
A1	GND	B12	GND
A2	TX1+	B11	RX1+
A3	TX1-	B10	RX1-
A4	VBUS	B9	VBUS
A5	CC1	B8	SBU2
A6	D+	B7	D-
A7	D-	B6	D+
A8	SBU1	B5	CC2
A9	VBUS	B4	VBUS
A10	RX2-	B3	TX2-
A11	RX2+	B2	TX2+
A12	GND	B1	GND

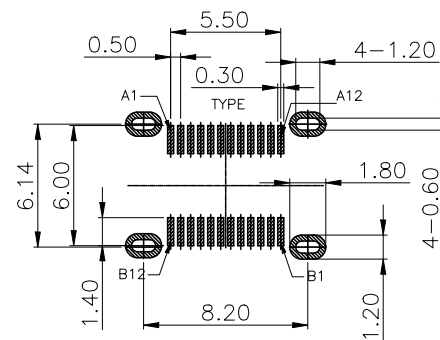
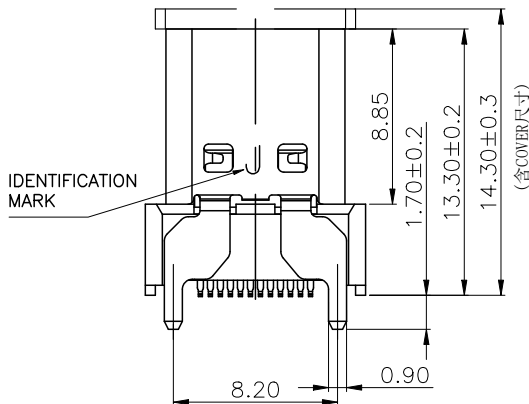

RECOMMEND P.C.B LAYOUT (COMPONENT SIDE)  
TOLERANCE FOR PCB LAYOUT IS ± 0.05



THIS DOCUMENT IS THE  
SOLE PROPERTY OF  
BBJconn Technology Co.,Ltd.  
Corporation AND SHOULD  
NOT BE USED IN WHOLE  
PRIOR WRITTEN PERMISSION.

**深圳市步步精科技有限公司**

.X: ±0.38 X': ±3'  
.XX: ±0.25 .X': ±2'  
.XXX: ±0.13 .XX': ±1'

NAME: TYPE-C 24P 母座 直立式 四脚插  
端子SMT 无柱 H=13.3 编带

APPD JM\_Zheng  
CHKD LYX

PJ NO: 126-224-240005-U4G  
SIZE:A4 DRW NO:

PDWG NO: 0470-1  
DR SGF

FINISH:SEE NOTES MAT'L:SEE NOTES  
SCALE:N/A REV:A0 UNIT:mm PAGE:1/2

**包装规范说明:**

1. 如图所示首先CARRIER TAPE (载带) 需先预留8PCS空格后方可置入成品,并附COVER TPAE(上带)覆盖于上,再配合带装机自动卷绕于REEL(塑胶卷轴)收料。  
As shown in picture, the initial starting carrier need to be emptied for 8 pcs, then put connector on Inth carrier; Then cover it with Cover Tape, and Reeling it with Reel auto machine.
2. 在定量包装完成后,前端CARRIER TAPE亦需预留8PCS空格,而COVER TPAE配合CARRIER TYPE长度覆盖后,并须再超出200mm以上,最后以胶纸贴固,并于REEL盘上方贴好标签.最外圈缠绕一圈保护带。  
In the end of the Reel, need to empty 8 pcs carrier tape; After covering the carrier, then the Cover Tape need to be 200mm longer, and use tape to fix the cover tape to the reel. Put qualified Label on the tape. The outermost ring is wound around a protective band.
3. 注意:COVER TAPE不可浮起或有贴附不顺,歪斜及成品放置方向错误的现象。  
Attention: no deformation of Cover Tape is allowed (protruded plastic, or not smooth, bednt or product is wrong positioned)
4. 在纸箱内左右,前后侧各放入一块三角卡板,每个PE袋中装入8个REEL盘,并在PE袋中放入2PCS干燥剂,用胶带封好.在纸箱内上下各垫一张平卡,每个纸箱内装入8PCS卷盘,共1叠.盖上箱盖后以胶带封箱,于图示位置贴好标签. Inside of carton, at left and right side, put triangle fixed card; Put 8 Reels to PE bag, and put 1 bags of desiccant inside the PE bag. Each carton has 8 reels. Put "Delivery label" on side of the carton.
5. 零箱部分, 出货时须用缓冲物填满。  
The fractional box must be filled by cushion before shipment.

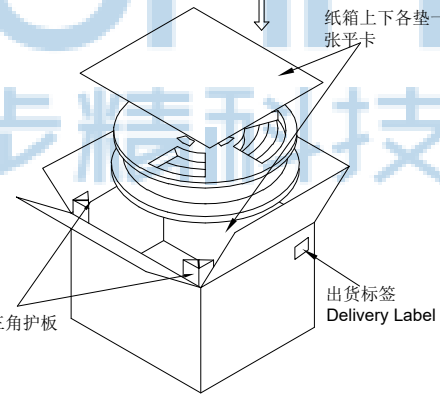
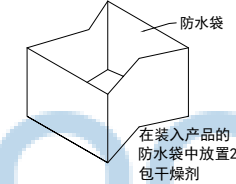
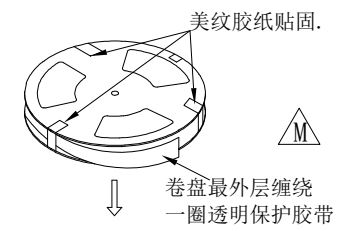

产品规格 Product spec.		
包装容量 Pcs/Reel	个 / 卷	250
Reel/Ctos.	卷 / 箱	8
QTY Pcs/Ctos.	个 / 箱	2000
重量 Weigh (Kg)	净重 N. W.	/kg
	毛重 G. W.	/kg

**PACKAGE**

1. SIZE :  
REEL :  $\phi 380 \times 32$  mm  
CARTON :  $400 \times 400 \times 325$  mm (LxWxH)
2. QUANTITY :  
450 PCS / REEL  
8 REEL / CARTON = 2000 PCS

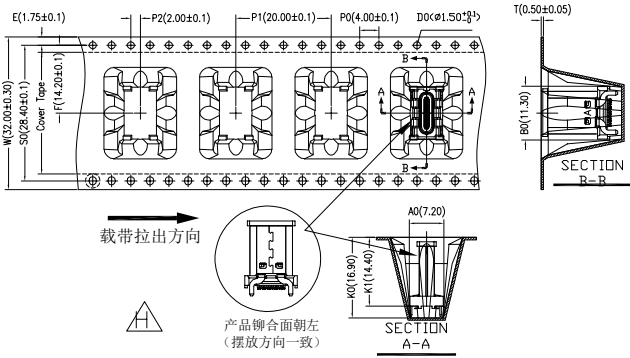
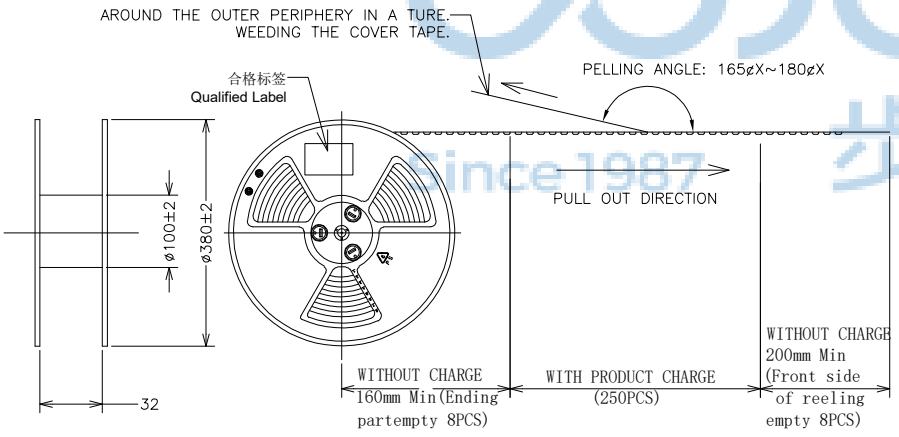

THIS DOCUMENT IS THE SOLE PROPERTY OF BBJconn Technology Co.,Ltd. Corporation AND SHOULD NOT BE USED IN WHOLE PRIOR WRITTEN PERMISSION.	深圳市步步精科技有限公司 工程 部		NAME: TYPE-C 24P 母座 直立式 四脚插 端子SMT 无柱 H=13.3 编带	
	APPD: JM_Zheng CHKD: LYX PDWG NO:0470-1	.X: ±0.38 .XX: ±0.25 .XXX: ±0.13	X': ±3' .X': ±2' .XX': ±1'	PJ NO: 126-224-240005-U4G SIZE:A4 FINISH:SEE NOTES SCALE:N/A