

REV	ECN NO	CONTENT	DATE	ENGINEER
A0		INITIAL RELEASE	/	SGF

NOTE/注释:

- SPECIFICATION/规格:
  - Rated current (额定电流): 5.0 A For Vbus pin  
1.25A For Vconn pin  
0.25A For Other pin
  - Voltage rating (额定电压): 5V AC
  - Contact Resistance (接触阻抗): 40 mΩ Max.
  - Insulation Resistance (绝缘阻抗): 100MΩ Min.
  - Withstanding voltage (耐电压): 100 VAC/minute
  - Mating force (插入力): 5~20N.
  - Unmating force (拔出力): 8~20N.
  - Durability Cycle (寿命循环): 10,000 cycle
  - Operating temperature (工作温度): -40° ~ +85°

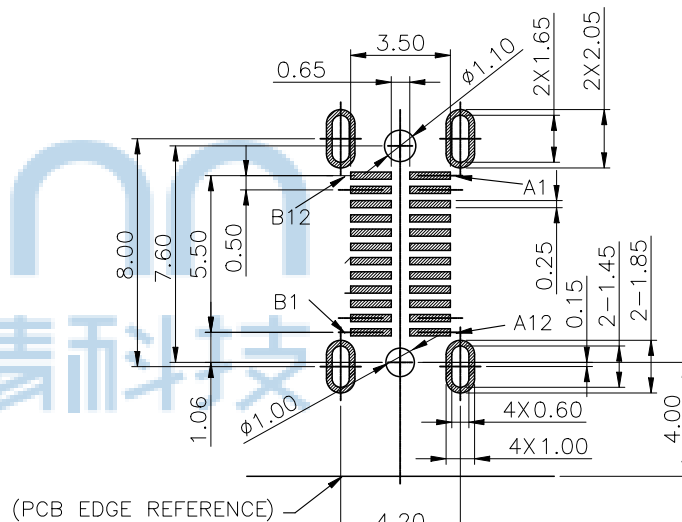
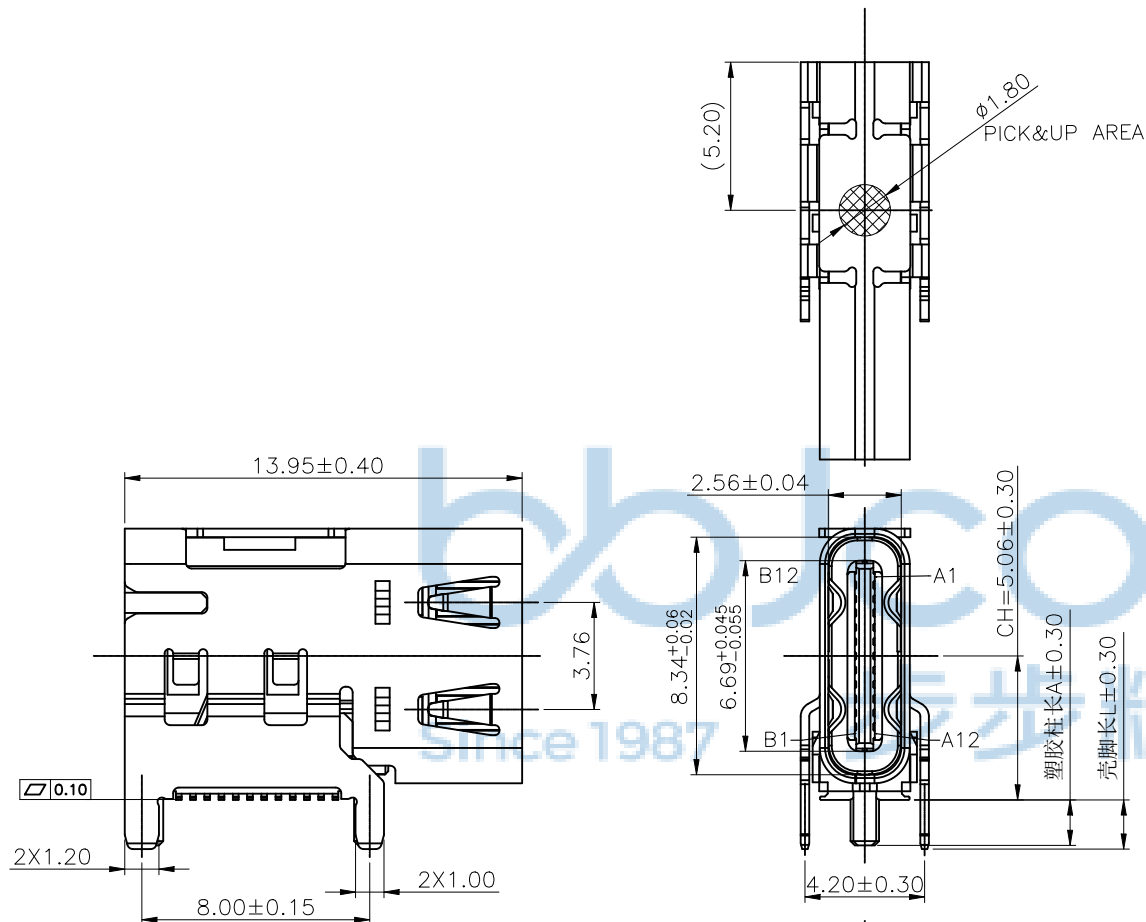

RECOMMENDED P.C.B LAYOUT  
TOLERANCE ± 0.05mm (TOP VIEW)

1.10	1.10
1.70	1.60

外壳脚长L 塑胶柱长A

ITEM	DESCRIPTION	Q'TY	MATERIAL	FINISH
4	TERMINAL	24	NKE012-EH(C18140)	MATING SIDE: Au SEE PART NO SOLDER TAIL: Gold_FLASH_50u" NICKEL OVERALL.
3	SHELL	1	SUS304	30U" MIN NICKEL PLATING
2	MID PLATE	1	SUS301	30U" MIN NICKEL PLATING
1	MAIN HOUSING	1	HIGH TEMPERATURE	LCP BLACK UL94V-0

BILL OF MATERIAL



PIN ASSIGNMENT

A1	A2	A3	A4	A5	A6	A7	A8	A9	A10	A11	A12
GND	TX1+	TX1-	Vbus	CC1	D+	D-	SBU1	Vbus	RX2-	RX2+	GND
GND	RX1+	RX1-	Vbus	SBU2	D-	D+	CC2	Vbus	TX2-	TX2+	GND
B12	B11	B10	B9	B8	B7	B6	B5	B4	B3	B2	B1

THIS DOCUMENT IS THE SOLE PROPERTY OF BBJconn Technology Co.,Ltd. Corporation AND SHOULD NOT BE USED IN WHOLE PRIOR WRITTEN PERMISSION.

PDWG NO: 0470-1

DR SGF

NAME: TYPE-C 24P 母座 侧插 四脚插 端子SMT 带柱 外壳脚长1.7 L=13.95 CH=5.06 编带

PJ NO: 126-227-240003-U4G

SIZE: A4 DRW NO:

FINISH: SEE NOTES MAT'L: SEE NOTES

SCALE: N/A REV: A0 UNIT: mm PAGE: 1/2

REV	ECN NO	CONTENT	DATE	ENGINEER
AO		INITIAL RELEASE	/	SGF

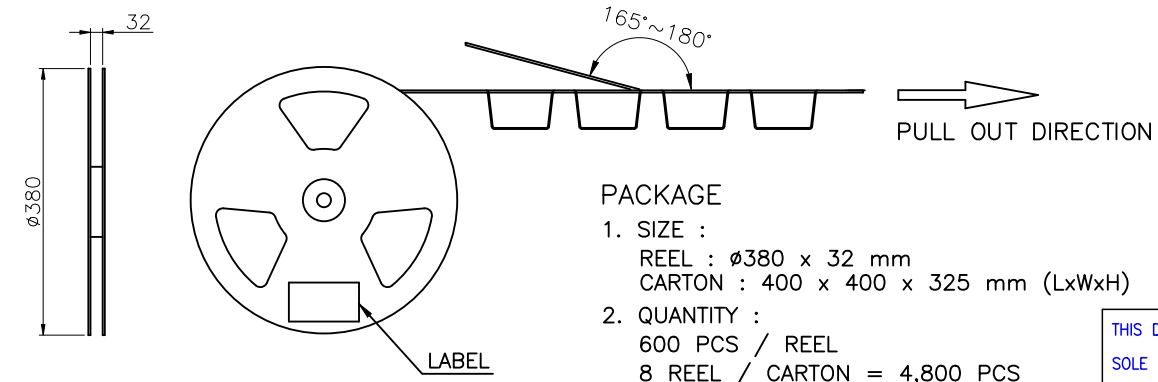
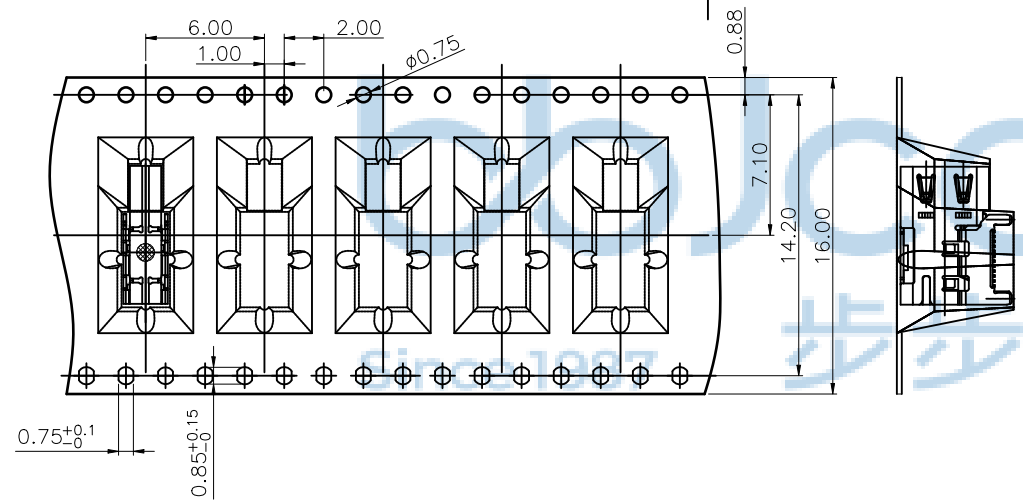
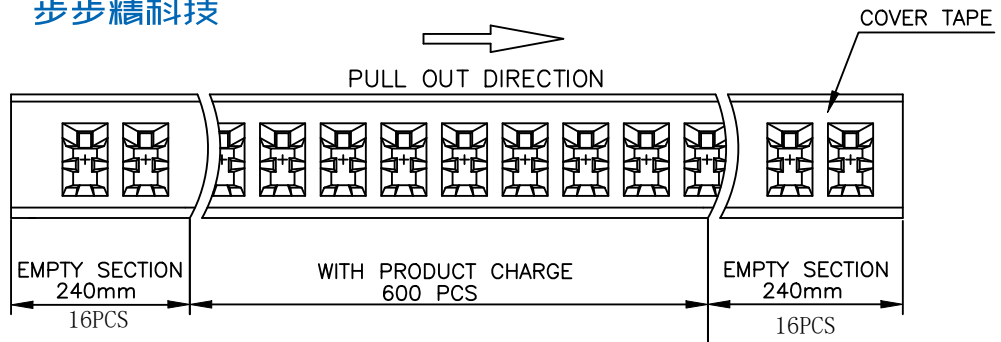

**PACKAGE**  
 1. SIZE :  
 REEL :  $\phi 380 \times 32$  mm  
 CARTON : 400 x 400 x 325 mm (LxWxH)  
 2. QUANTITY :  
 600 PCS / REEL  
 8 REEL / CARTON = 4,800 PCS

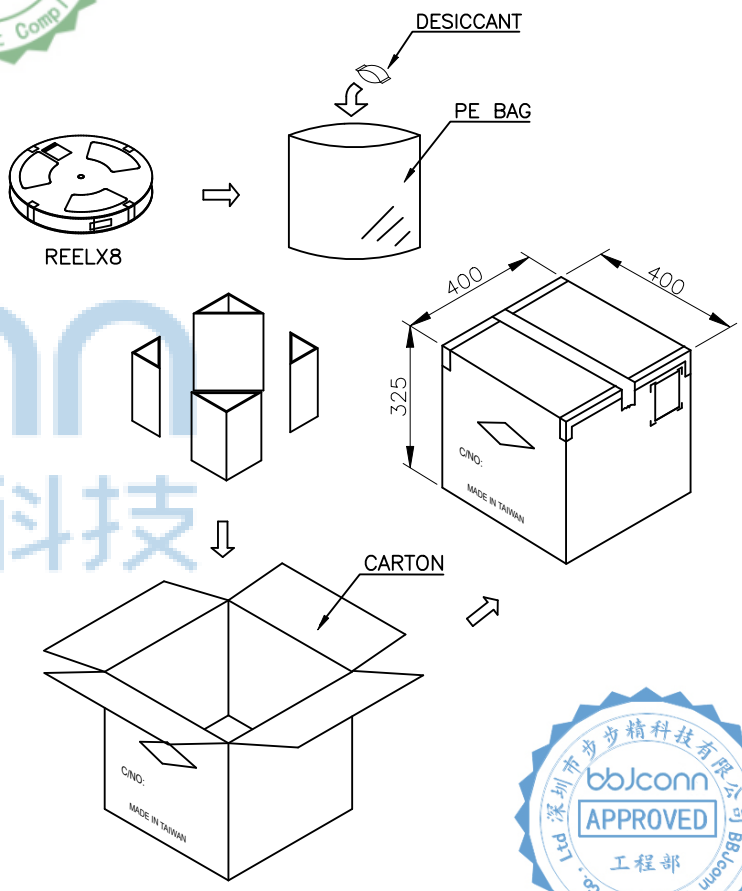

THIS DOCUMENT IS THE SOLE PROPERTY OF BBJconn Technology Co.,Ltd. Corporation AND SHOULD NOT BE USED IN WHOLE PRIOR WRITTEN PERMISSION.		<b>深圳市步步精科技有限公司</b>	
PDWG NO: 0470-1		NAME: TYPE-C 24P 母座 侧插 四脚插 端子SMT 带柱 外壳脚长1.7 L=13.95 CH=5.06 编带	
APPD	JM_Zheng	PJ NO: 126-227-240003-U4G	
CHKD	LYX	SIZE:A4 DRW NO:	
DR	SGF	FINISH:SEE NOTES MAT'L:SEE NOTES	
		SCALE:N/A REV:A0 UNIT:mm PAGE:2/2	