

REV.	ECN NO.	CONTENT	DATE	ENGINEER
A0		Initial release	/	SGF

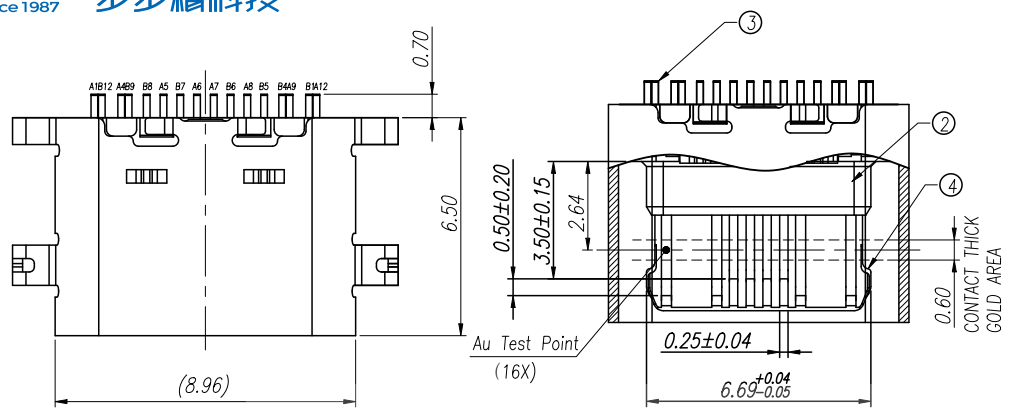

**SPECIFICATION:**

- ELECTRICAL CHARACTERISTICS:**
  - CURRENT RATING: 5A
  - TEMPERATURE RANGE: -40 °C ~ 85 °C
  - CONTACT RESISTANCE: 30 MILLIONHM MAX.
  - DIELECTRIC WITHSTANDING VOLTAGE: 100 VAC r.m.s
  - INSULATION RESISTANCE: 100 MEGOHMS MIN.
- MECHANICAL CHARACTERISTICS**
  - INSERTION FORCE: 5~20N
  - EXTRACTION FORCE: Initial:8~20N,ATER TEST 6~20N
  - DURABILITY:10,000CYCLES
- THE SHELL LENTH IS LESS THAN THE MINIMUM SPECIFIED BY THE USB TYPE C STANDARD.AS SUCH IS CONNOT INDENOENDENTLY BE GUARANTEED TO MEET ALL TYPE C MECHANICAL REQUIREMENTS.
- SALT SPRAY:48H.**

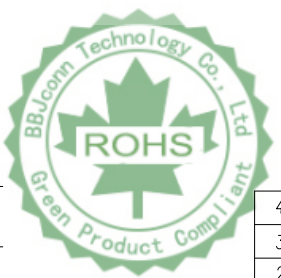
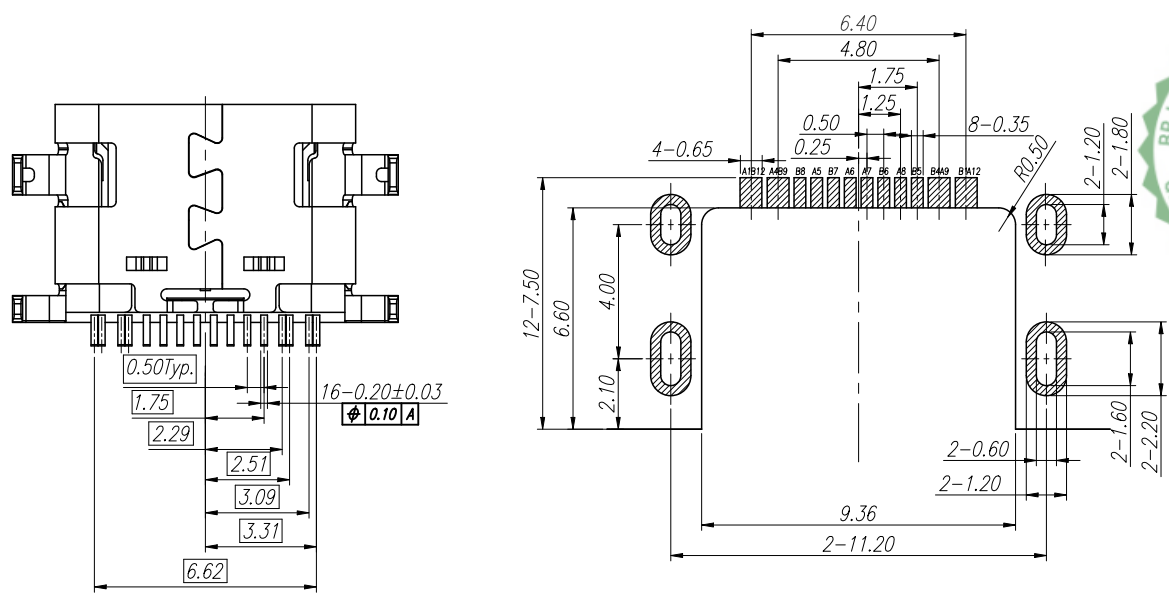
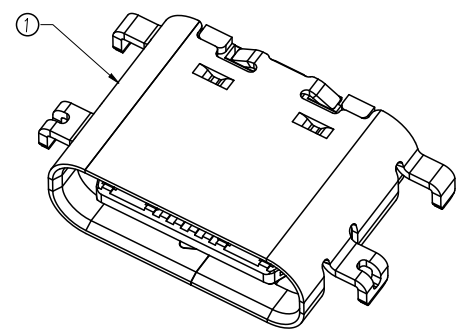
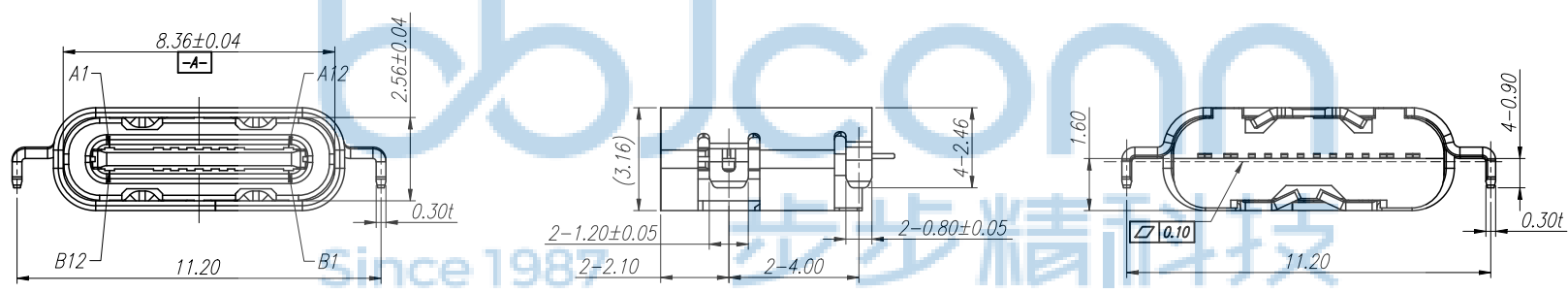

PIN ASSIGNMENT												BLADE	SHELL
A1	A2	A3	A4	A5	A6	A7	A8	A9	X10	X11	A12		
GND	TX1+	TX1-	VBUS	CC1	D+	D-	SBU1	VBUS	RX2-	RX2+	GND		
GND	RX1+	RX1-	VBUS	SBU2	D-	D+	CC2	VBUS	TX2-	TX2+	GND	GND	GND
B12	B11	B10	B9	B8	B7	B6	B5	B4	B3	B2	B1		

NO.	DESCRIPTION	QTY.	MATERIAL	FINISHED
4	MID PLATE	1 PCS	SUS301	Cleaning
3	CONTACT	1 SET	C2680	Au G/F & Ni 50u
2	MOLDING HOUSING	1 PCS	PA46	None
1	SHELL	1 PCS	SUS304	Ni 50U MIN

THIS DOCUMENT IS THE SOLE PROPERTY OF BBJconn Technology Co.,Ltd. Corporation AND SHOULD NOT BE USED IN WHOLE OR IN PART WITHOUT PRIOR WRITTEN PERMISSION. PDWNG:NO: 0851-1

**深圳市步步精科技有限公司**

NAME: TYPE-C 16P 母座 板上四脚插 端子SMT  
L=6.50 沉板=1.60 PA46 不锈钢外壳304 编带

PJ. NO.: 126-221-160026-M3G  
SIZE: A4 DRW NO.:

FINISH: SEE NOTES MAT'L.: SEE NOTES  
SCALE: N/A REV.: A0 UNIT: mm PAGE: 1/2

APPD. JM\_Zheng  
CHKD. LYX  
DR. SGF

REV.	ECN NO	CONTENT	DATE	ENGINEER
AO		Initial release	/	SGF

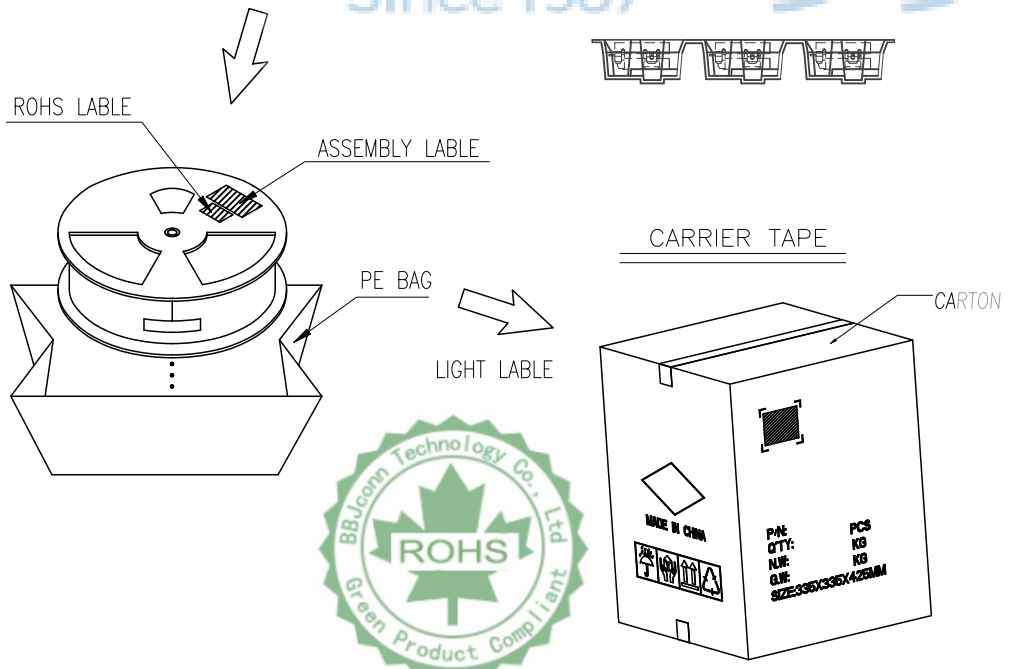
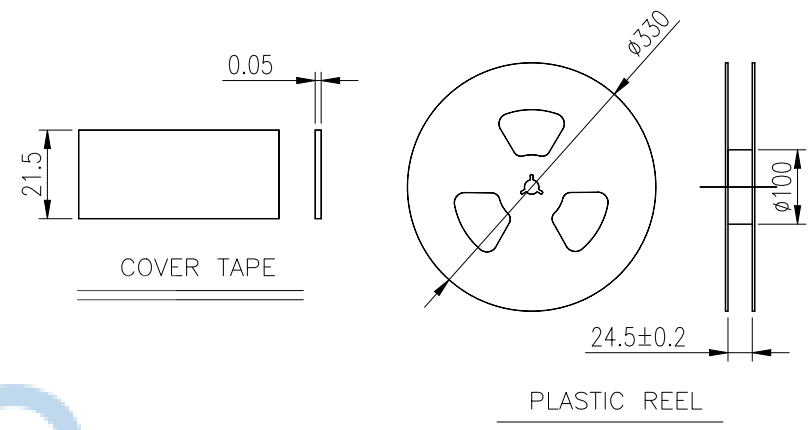
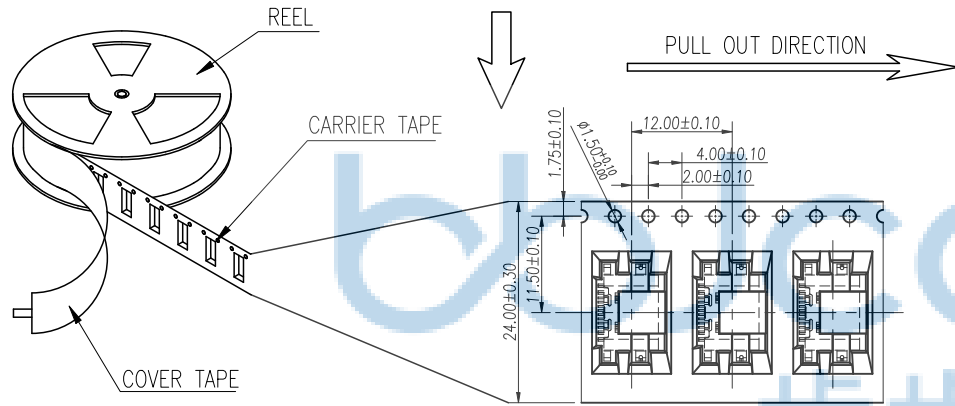
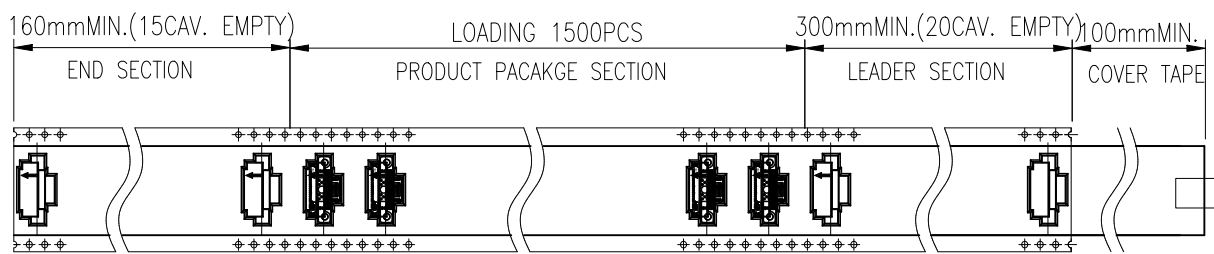

- NOTES 2:
- MATERIAL:
    - 1.1 REEL AND AXLE: PS,BLUE
    - 1.2 CARRIER TAPE: PET, LUCID
    - 1.3 COVER TAPE: PS,TRANSPARENT
    - 1.4 SHIPPING CARTON: CORRUGATED FIBER
  - DIMENSION:
    - 2.1 REEL: W=24.5,  $\phi A=330$
    - 2.2 CARRIER TAPE: T=0.30 W=24.0
    - 2.3 COVER TAPE: T=0.05 W=21.5
    - 2.4 SHIPPING CARTON: L=335mm, W=335mm, H=425mm
  - QUANTITY :
    - 3.1 PRIMAY PACKING: 1500PCS/REEL
    - 3.2 SECONARY PACKING: 10 REELS/CARTON(15000PCS/CARTON)
  - PEELING RESISTANCE: 0.1~1.3N
    - 4.1 PEELING SPEED: 300mm/minutes
    - 4.2 PEELING ANGLE: 165° ~180°



THIS DOCUMENT IS THE SOLE PROPERTY OF BBJconn Technology Co.,Ltd. Corporation AND SHOULD NOT BE USED IN WHOLE OR IN PART WITHOUT PRIOR WRITTEN PERMISSION.		<b>深圳市步步精科技有限公司</b>	
.X: ±0.38 X': ±3" .XX: ±0.25 X'': ±2" .XXX: ±0.13 .XX': ±1"		NAME: TYPE-C 16P 母座 板上四脚插 端子SMT L=6.50 沉板=1.60 PA46 不锈钢外壳304 编带	
APPD.	JM_Zheng	P.J. NO.: 126-221-160026-M3G SIZE: A4 DRW NO.:	
CHKD.	LYX	FINISH: SEE NOTES MAT'L.: SEE NOTES	
PDWG.NO:	0851-1	SCALE: N/A	REV.: AO UNIT: mm PAGE: 2/2
DR.	SGF		