

REV	ECN NO	CONTENT	DATE	ENGINEER
A0		INITIAL RELEASE	/	SGF

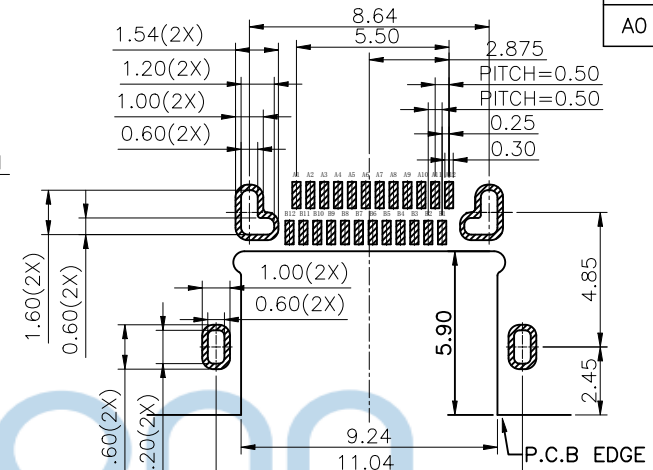
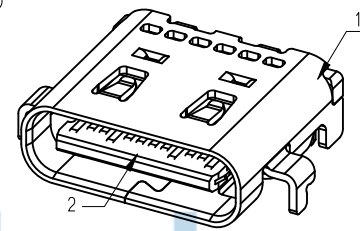
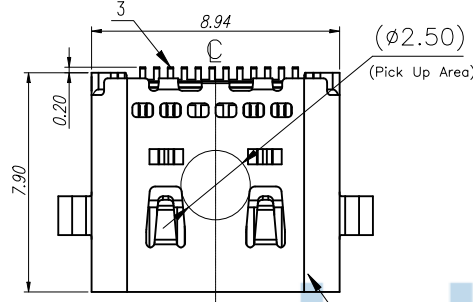

SPECIFICATION:

- ELECTRICAL CHARACTERISTICS:**
 - CURRENT RATING: 5 A
 - TEMPERATURE RANGE: -40 °C ~ 85 °C
 - CONTACT RESISTANCE: 30 MILLIONHM MAX.
 - DIELECTRIC WITHSTANDING VOLTAGE: 100 VAC r.m.s
 - INSULATION RESISTANCE: 100 MEGOHMS MIN.
- MECHANICAL CHARACTERISTICS**
 - INSERTION FORCE: 5~20N
 - EXTRACTION FORCE: Initial:8~20N,ATER TEST 6~20N
 - DURABILITY:10,000CYCLES
- THE SHELL LENTH IS LESS THAN THE MINIMUM SPECIFIED BY THE USB TYPE C STANDARD,AS SUCH IS CONNOT INDEPENDENTLY BE GUARANTEED TO MEET ALL TYPE C MECHANICAL REQUIREMENTS.

RECOMMENDED PCB LAYOUT(TOP VIEW)
THICKNESS 0.60MM;DEFAULT TOLERANCE:±0.05

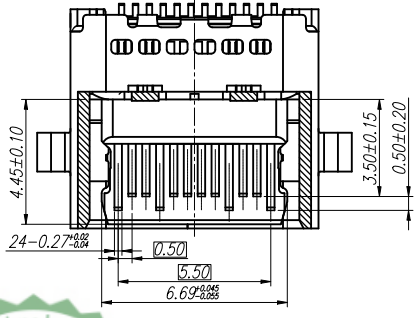
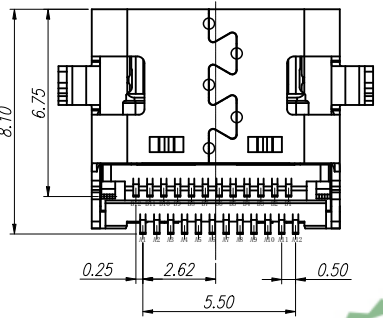
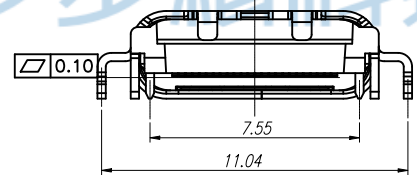
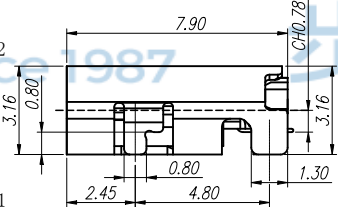
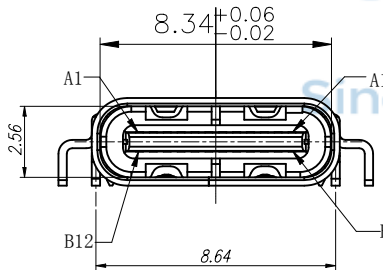

PIN ASSIGNMENT			
Pin No.	Signal Name	Pin No.	Signal Name
A1	GND	B12	GND
A2	TX1+	B11	RX1+
A3	TX1-	B10	RX1-
A4	VBUS	B9	VBUS
A5	CC1	B8	SBU2
A6	D+	B7	D-
A7	D-	B6	D+
A8	SBU1	B5	CC2
A9	VBUS	B4	VBUS
A10	RX2-	B3	TX2-
A11	RX2+	B2	TX2+
A12	GND	B1	GND

Item	Description	QTY.	Material	Finish
4	Shielding plate	1	SUS 301	Ni underplating overall, Gold Flash plating on the solder tail.
3	Contact	24	C18400	Ni underplating overall, Au plating on the contact area, Gold Flash plating on the solder tail.
2	IM	1	LCP	UL94V-0, Black/White
1	Shell	1	SUS 304	Ni plating overall



THIS DOCUMENT IS THE SOLE PROPERTY OF **bbJconn Technology Co.,Ltd.** CORPORATION AND SHOULD NOT BE USED IN WHOLE PRIOR WRITTEN PERMISSION.

深圳市步步精科技有限公司

NAME: TYPE-C 24P 母座 L=7.90 CH=0.78 四脚插 沉板0.80 304外壳带弹 端子双排SMT

APPD: JM_Zheng
CHKD: Tang
PDWG NO:0851-1

PJ NO: 126-221-160032-M3G
SIZE:A4
FINISH:SEE NOTES
SCALE:N/A

MAT'L:SEE NOTES
DRW NO:
UNIT:mm
PAGE:1/2

REV	ECN NO	CONTENT	DATE	ENGINEER
AO		INITIAL RELEASE	/	SGF

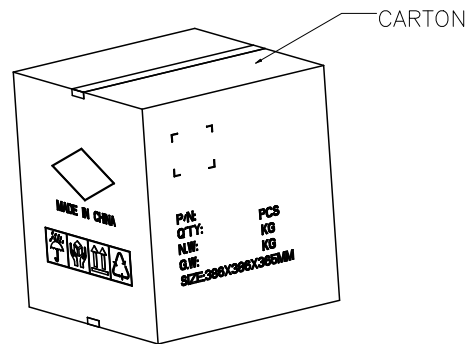
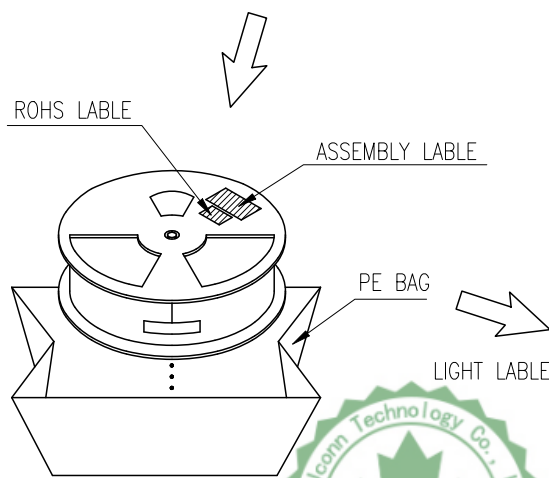
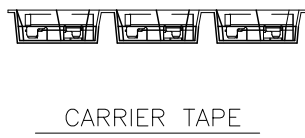
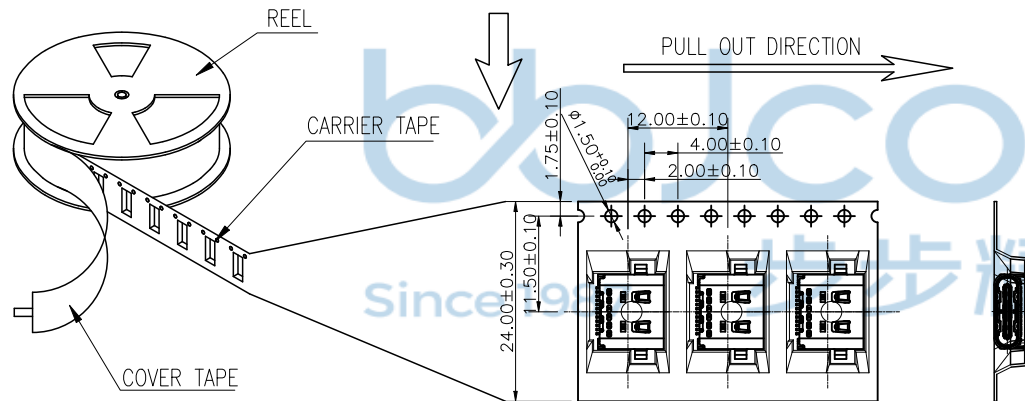
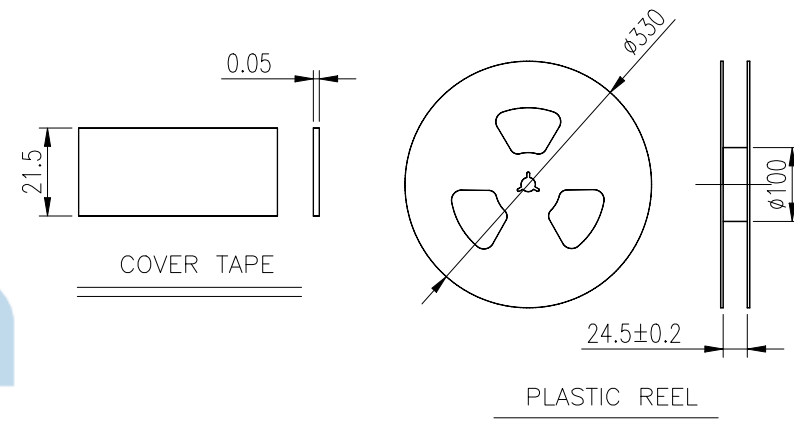
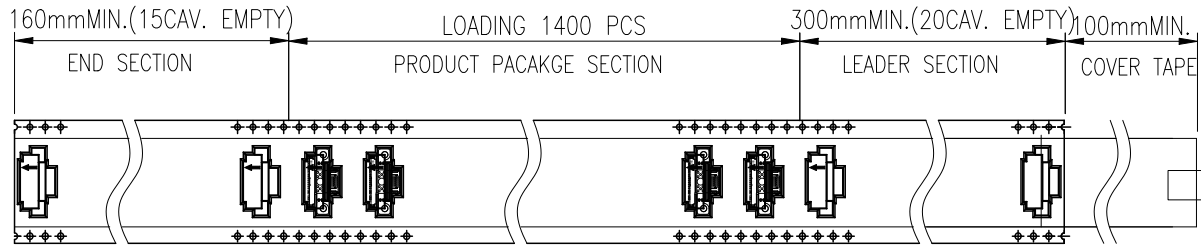

NOTES 2:

1. MATERIAL:

- 1.1 REEL AND AXLE: PS,BLUE
- 1.2 CARRIER TAPE: PET, LUCID
- 1.3 COVER TAPE: PS,TRANSPARENT
- 1.4 SHIPPING CARTON: CORRUGATED FIBER

2. DIMENSION:

- 2.1 REEL: W=24.5, ØA=330
- 2.2 CARRIER TAPE: T=0.30 W=24.0
- 2.3 COVER TAPE: T=0.05 W=21.5
- 2.4 SHIPPING CARTON: L=335mm, W=335mm, H=365mm

3. QUANTITY :

- 3.1 PRIMAY PACKING: 1400 PCS/REEL
- 3.2 SECONARY PACKING: 12 REELS/CARTON(16800 PCS/CARTON)

4. PEELING RESISTANCE: 0.1~1.3N

- 4.1 PEELING SPEED: 300mm/minutes
- 4.2 PEELING ANGLE: 165° ~180°

THIS DOCUMENT IS THE SOLE PROPERTY OF BBJconn Technology Co.,Ltd. Corporation AND SHOULD NOT BE USED IN WHOLE PRIOR WRITTEN PERMISSION.		深圳市步步精科技有限公司 .X: ±0.38 .X': ±3' .XX: ±0.25 .X'': ±2' .XXX: ±0.13 .X'': ±1'		NAME: TYPE-C 24P 母座 L=7.90 CH=0.78 四脚插 沉板0.80 304外壳带弹 端子双排SMT PJ NO: 126-221-160032-M3G SIZE:A4 DRW NO:	
APPD	JM_Zheng			FINISH:SEE NOTES MAT'L:SEE NOTES	
CHKD	Tang	SCALE:N/A REV:A0 UNIT:mm PAGE:1/2			
PDWG NO:0851-1	DR	LYX			