

| REV | ECN NO | CONTENT | DATE | ENGINEER |
|-----|--------|-----------------|------|----------|
| A0 | | INITIAL RELEASE | / | SGF |

SPECIFICATION:

1.ELECTRICAL CHARACTERISTICS:

- 1.1 CURRENT RATING: 3A
- 1.2 TEMPERATURE RANGE: -40 °C ~ 85 °C
- 1.3 CONTACT RESISTANCE: 30 MILLIONHM MAX.
- 1.4 DIELECTRIC WITHSTANDING VOLTAGE: 100 VAC r.m.s
- 1.5 INSULATION RESISTNACE: 100 MEGOHMS MIN.

2.MECHANICAL CHARACTERISTICS

- 2.1 INSERTION FORCE: 5~20N
- 2.2 EXTRACTION FORCE: Initial:8~20N,ATER TEST 6~20N
- 2.3 DURABILITY:10,000CYCLES

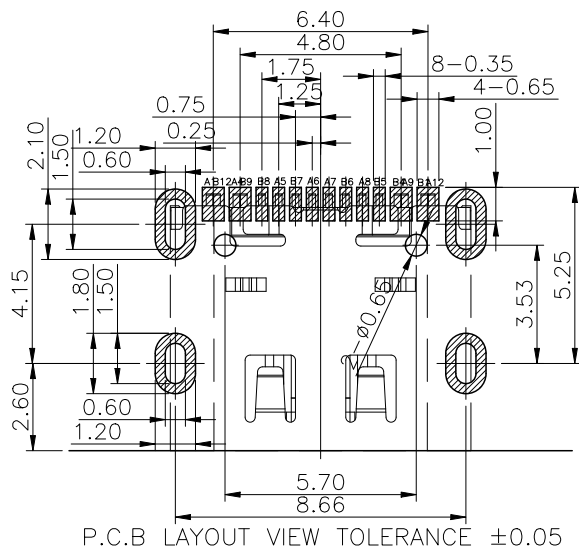
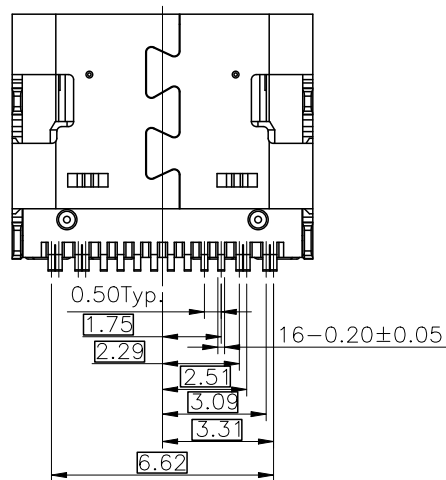
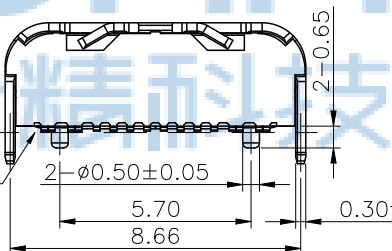
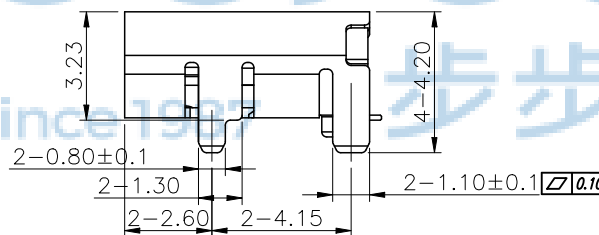
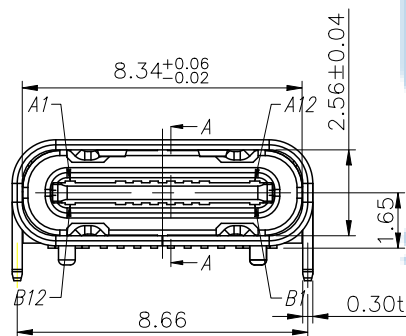
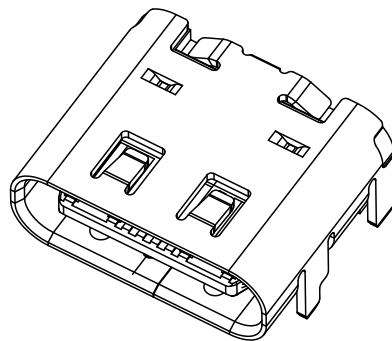
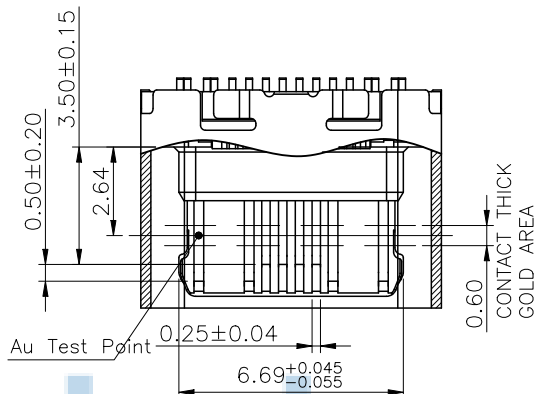
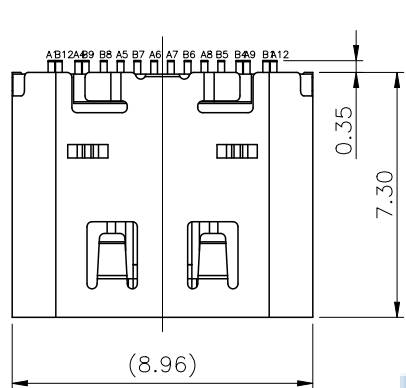

| PIN ASSIGNMENT | | | | | | | | | | | | BLADE | SHELL |
|----------------|------|------|------|------|----|----|------|------|------|------|-----|-------|-------|
| A1 | A2 | A3 | A4 | A5 | A6 | A7 | A8 | A9 | X10 | X11 | A12 | | |
| GND | TX1+ | TX1- | VBUS | CC1 | D+ | D- | SBU1 | VBUS | RX2+ | RX2- | GND | | |
| GND | RX1+ | RX1- | VBUS | SBU2 | D+ | D- | CC2 | VBUS | TX2+ | TX2- | GND | GND | GND |
| B12 | B11 | B10 | B9 | B8 | B7 | B6 | B5 | B4 | B3 | B2 | B1 | | |

| NO. | DESCRIPTION | QTY. | MATERIAL | FINISHED |
|-----|-----------------|-------|----------|----------------|
| 4 | MID PLATE | 1 PCS | SUS301 | None |
| 3 | CONTACT | 1 SET | C7025 | Au & Ni Plated |
| 2 | MOLDING HOUSING | 1 PCS | PA46 | None |
| 1 | SHELL | 1 PCS | SUS304 | Ni Plated |

THIS DOCUMENT IS THE SOLE PROPERTY OF BBJconn Technology Co.,Ltd. Corporation AND SHOULD NOT BE USED IN WHOLE PRIOR WRITTEN PERMISSION. PDWG NO: 0851-1

深圳市步步精科技有限公司

NAME: TYPE-C 16P 母座 板上四脚插 带柱 外壳 带弹 端子SMT L=7.30 CH=1.65 编带

APPD: JM_Zheng PJ NO: 126-221-160036-M3G

CHKD: LYX SIZE:A4 DRW NO:

FINISH:SEE NOTES MAT'L:SEE NOTES

SCALE:N/A REV:A0 UNIT:mm PAGE:1/2

| REV | ECN NO | CONTENT | DATE | ENGINEER |
|-----|--------|-----------------|------|----------|
| A0 | | INITIAL RELEASE | / | SGF |

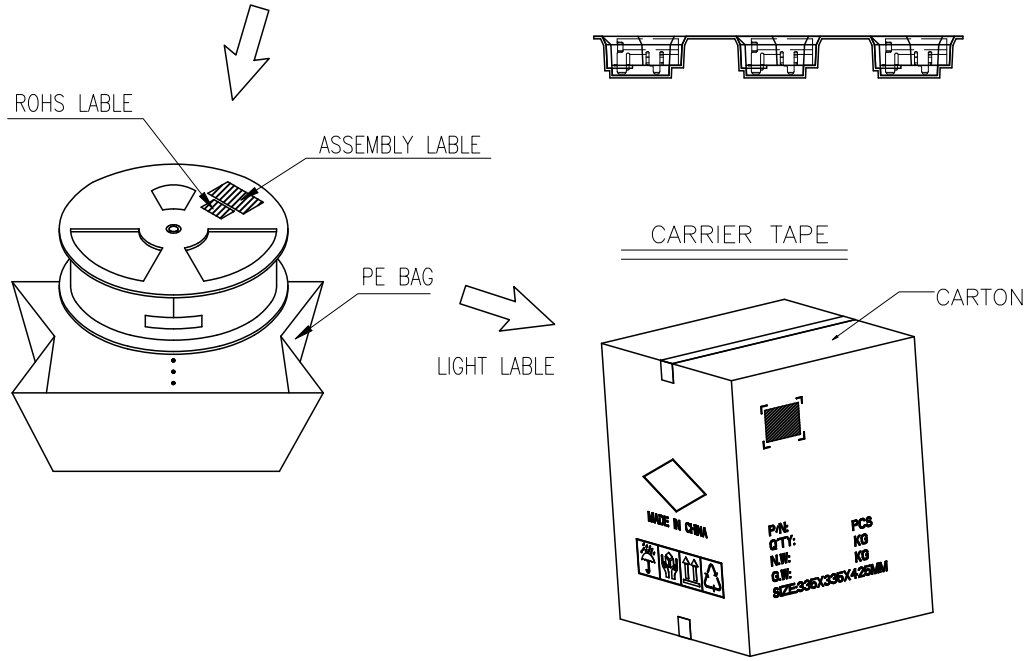
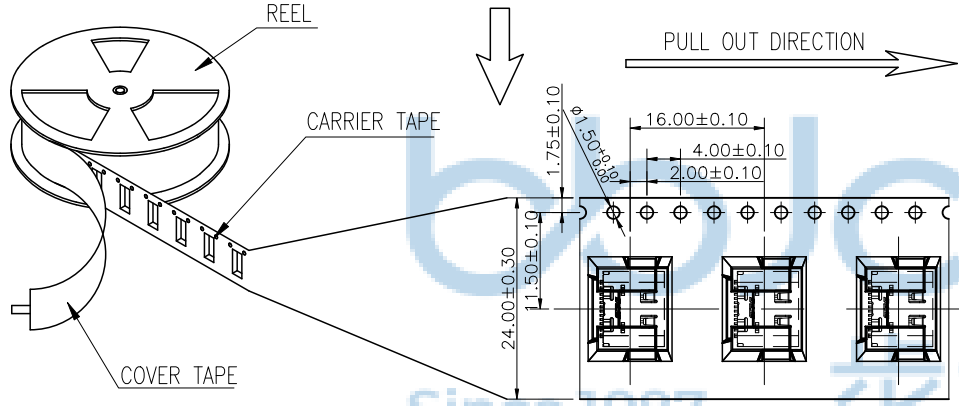
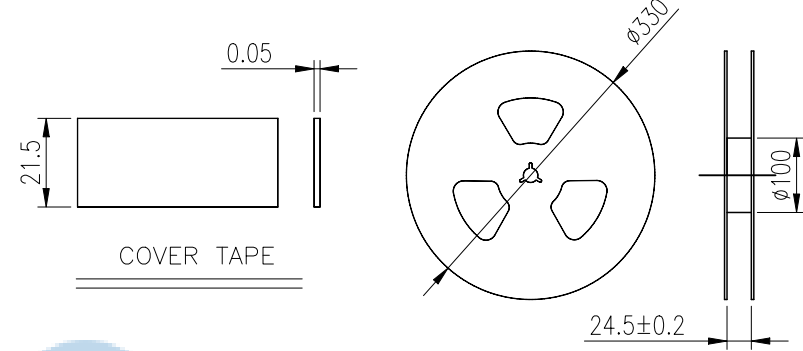
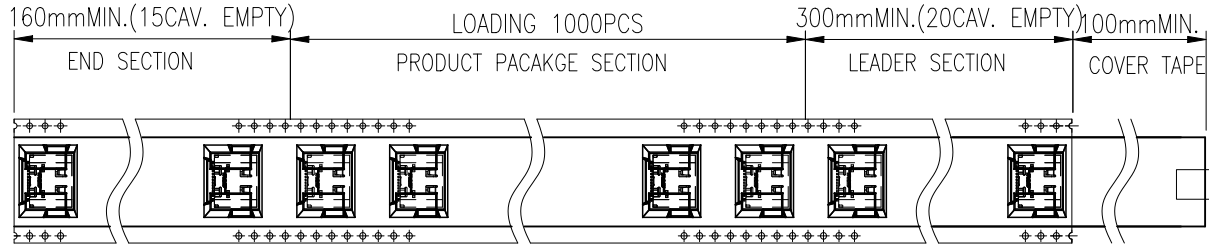

- NOTES 2:
- MATERIAL:
 - 1.1 REEL AND AXLE: PS,BLUE
 - 1.2 CARRIER TAPE: PET, LUCID
 - 1.3 COVER TAPE: PS,TRANSPARENT
 - 1.4 SHIPPING CARTON: CORRUGATED FIBER
 - DIMENSION:
 - 2.1 REEL: W=24.5, φA=330
 - 2.2 CARRIER TAPE: T=0.50 W=24.0
 - 2.3 COVER TAPE: T=0.05 W=21.5
 - 2.4 SHIPPING CARTON: L=335mm, W=335mm, H=425mm
 - QUANTITY :
 - 3.1 PRIMAY PACKING: 1000PCS/REEL
 - 3.2 SECONARY PACKING: 12 REELS/CARTON(12000PCS/CARTON)
 - PEELING RESISTANCE: 0.1~1.3N
 - 4.1 PEELING SPEED: 300mm/minutes
 - 4.2 PEELING ANGLE: 165°~180°



| | | | |
|-----------------------------------------------------------------------------------------------------------------------------------------|----------|------------------------------------------------------------|-------------------------------------------------------------------------------|
| THIS DOCUMENT IS THE SOLE PROPERTY OF BBJconn Technology Co.,Ltd. Corporation AND SHOULD NOT BE USED IN WHOLE PRIOR WRITTEN PERMISSION. | | 深圳市步步精科技有限公司 | |
| .X: ±0.38 .XX: ±0.25 .XXX: ±0.13 X': ±3" X'': ±2" XX': ±1" | | NAME: TYPE-C 16P 母座 板上四脚插 带柱 外壳 带弹 端子SMT L=7.30 CH=1.65 编带 | |
| APPD | JM_Zheng | PJ NO: 126-221-160036-M3G SIZE:A4 DRW NO: | FINISH:SEE NOTES MAT'L:SEE NOTES SCALE:N/A REV:A0 UNIT:mm PAGE:2/2 |
| CHKD | LYX | | |
| PDWG NO: 0851-1 | DR | SGF | |