

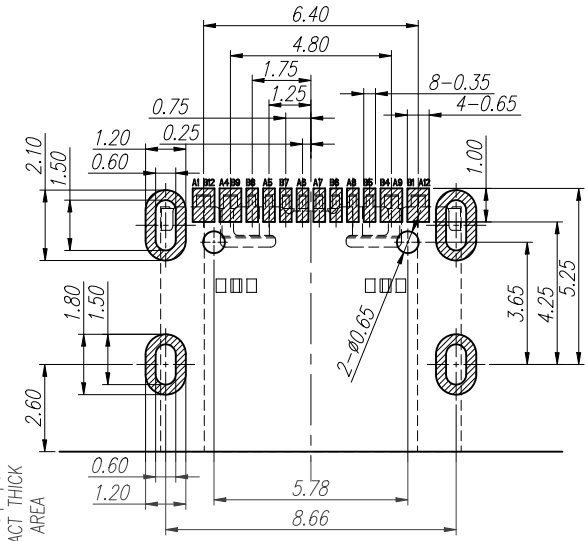

REV.	ECN NO.	CONTENT	DATE	ENGINEER
A0		Initial release	/	SGF



SPECIFICATION:

- ELECTRICAL CHARACTERISTICS:
 - CURRENT RATING: 3A/5A
 - TEMPERATURE RANGE: -40 °C ~ 85 °C
 - CONTACT RESISTANCE: 30 MILLIONHM MAX.
 - DIELECTRIC WITHSTANDING VOLTAGE: 100 VAC r.m.s
 - INSULATION RESISTNACE: 100 MEGOHMS MIN.
- MECHANICAL CHARACTERISTICS
 - INSERTION FORCE: 5~20N
 - EXTRACTION FORCE: Initial:8~20N,ATER TEST 6~20N
 - DURABILITY:10,000CYCLES
- THE SHELL LENTH IS LESS THAN THE MINIMUM SPECIFIED BY THE USB TYPE C STANDARD,AS SUCH IS CONNOT INDENOENDENTLY BE GUARANTEED TO MEET ALL TYPE C MECHANICAL REQUIREMENTS.

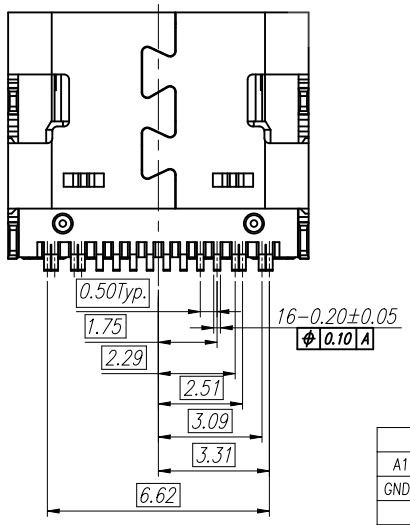
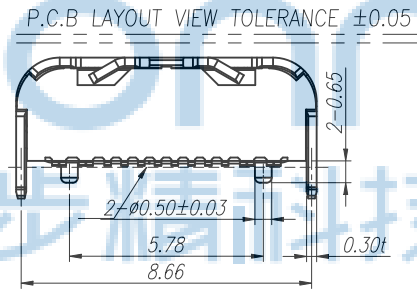
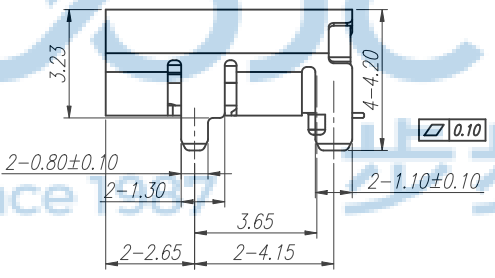
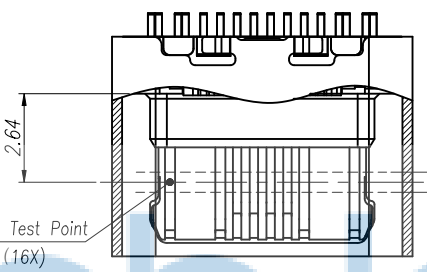
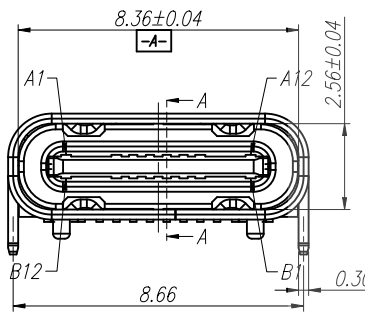
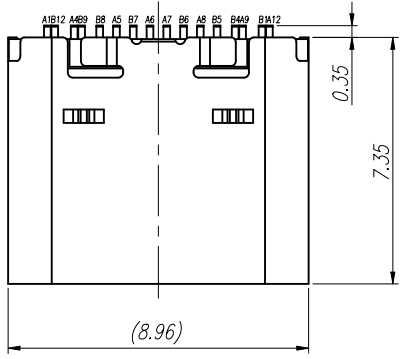
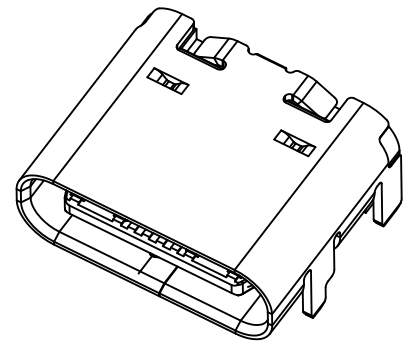

PIN ASSIGNMENT												BLADE	SHELL
A1	A2	A3	A4	A5	A6	A7	A8	A9	A10	A11	A12		
GND	TX1+	TX1-	VBUS	CC1	D+	D-	SBU1	VBUS	RX2-	RX2+	GND		
GND	RX1+	RX1-	VBUS	SBU2	D-	D+	CC2	VBUS	TX2-	TX2+	GND	GND	GND
B12	B11	B10	B9	B8	B7	B6	B5	B4	B3	B2	B1		

TABLE A

NO.	DESCRIPTION	QTY.	MATERIAL	FINISHED
4	MID PLATE	1 PCS	SUS301	None
3	CONTACT	1 SET	C2680	Au15u & Ni Plated
2	MOLDING HOUSING	1 PCS	PA46	None
1	SHELL	1 PCS	SUS304	Ni Plated

THIS DOCUMENT IS THE SOLE PROPERTY OF BBJconn Technology Co.,Ltd. Corporation AND SHOULD NOT BE USED IN WHOLE OR IN PART WITHOUT PRIOR WRITTEN PERMISSION.
PDWNG.NO: 0851-1

深圳市步步精科技有限公司

NAME:TYPE-C 16P 母座 板上四脚插 端子SMT L=7.35 带柱 不锈钢304外壳 过5A电流 镀金15u 编带

APPD. JM_Zheng
CHKD. LYX
DR. SGF

PJ. NO.: 126-221-160046-M3G
SIZE: A4
FINISH: SEE NOTES
SCALE: N/A

REV.: A0
UNIT: mm
PAGE: 1/2

REV.	ECN NO.	CONTENT	DATE	ENGINEER
AO		Initial release	/	SGF

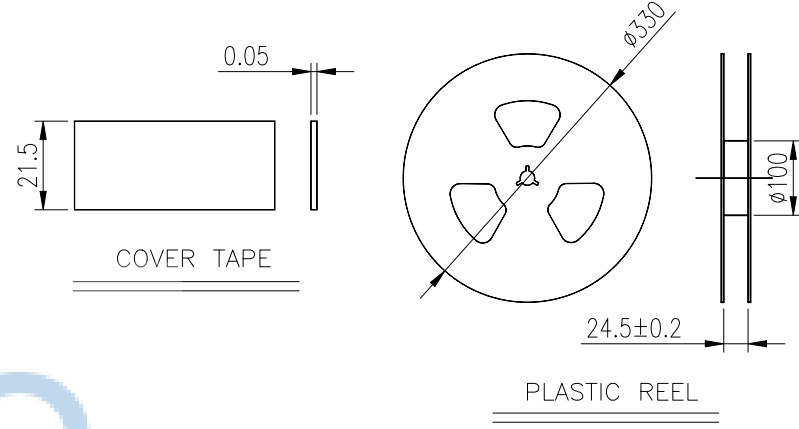
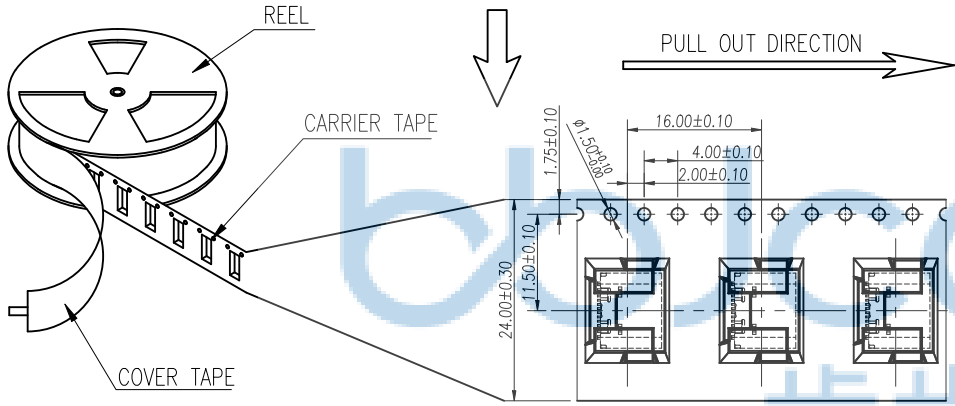
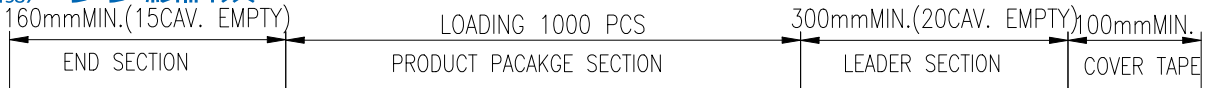

- NOTES 2:
- MATERIAL:
 - REEL AND AXLE: PS,BLUE
 - CARRIER TAPE: PET, LUCID
 - COVER TAPE: PS,TRANSPARENT
 - SHIPPING CARTON: CORRUGATED FIBER
 - DIMENSION:
 - REEL: W=24.5, øA=330
 - CARRIER TAPE: T=0.50 W=24.0
 - COVER TAPE: T=0.05 W=21.5
 - SHIPPING CARTON: L=335mm, W=335mm, H=425mm
 - QUANTITY :
 - PRIMAY PACKING: 1000PCS/REEL
 - SECONDARY PACKING: 10 REELS/CARTON(10000PCS/CARTON)
 - PEELING RESISTANCE: 0.1~1.3N
 - PEELING SPEED: 300mm/minutes
 - PEELING ANGLE: 165° ~180°

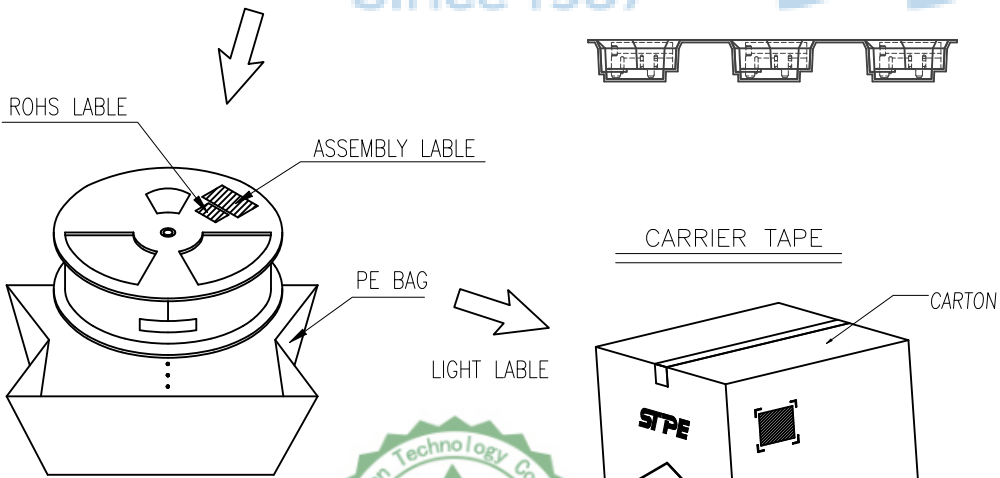

THIS DOCUMENT IS THE SOLE PROPERTY OF BBJconn Technology Co.,Ltd. Corporation AND SHOULD NOT BE USED IN WHOLE OR IN PART WITHOUT PRIOR WRITTEN PERMISSION.		深圳市步步精科技有限公司 工程 部	
PDWG.NO: 0851-1		.X: ±0.38 .XX: ±0.25 .XXX: ±0.13 X': ±3" .X': ±2" .XX': ±1"	NAME: TYPE-C 16P 母座 板上四脚插 端子SMT L=7.35 带柱 不锈钢304外壳 过5A电流 镀金15u 编带 APPD. JM_Zheng CHKD. LYX DR. SGF
		PJ. NO.: 126-221-160046-M3G SIZE: A4 DRW NO.:	FINISH: SEE NOTES MAT'L.: SEE NOTES SCALE: N/A REV.: AO UNIT: mm PAGE: 2/2