

REV.	ECN NO	CONTENT	DATE	ENGINEER
A0		Initial release	/	GZY

SPECIFICATION:

- ELECTRICAL CHARACTERISTICS:
 - CURRENT RATING: 5A
 - TEMPERATURE RANGE: -40 °C ~ 85 °C
 - CONTACT RESISTANCE: 30 MILLIONHM MAX.
 - DIELECTRIC WITHSTANDING VOLTAGE: 100 VAC r.m.s
 - INSULATION RESISTNACE: 100 MEGOHMS MIN.
- MECHANICAL CHARACTERISTICS
 - INSERTION FORCE: 5~20N
 - EXTRACTION FORCE: Initial:8~20N ATER TEST 6~20N;
 - DURABILITY:10,000CYCLES
- THE SHELL LENTH IS LESS THAN THE MINIMUM SPECIFIED BY THE USB TYPE C STANDARD.AS SUCH IS CONNOT INDENOENDENTLY BE GUARANTEED TO MEET ALL TYPE C MECHANICAL REQUIREMENTS.

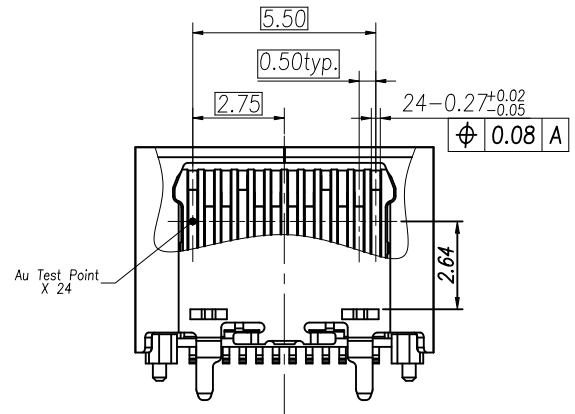
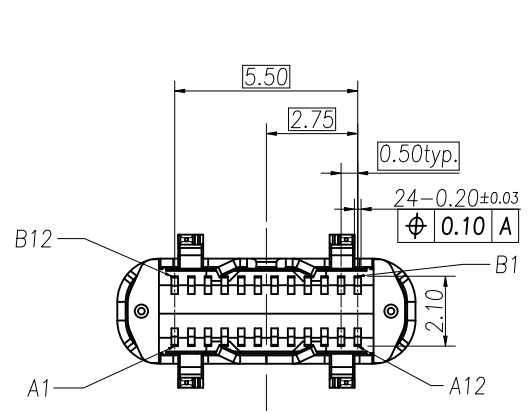
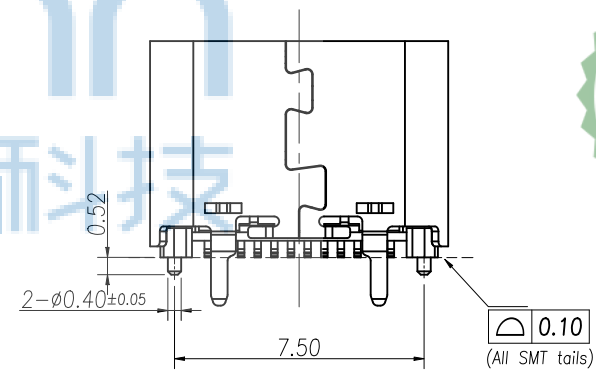
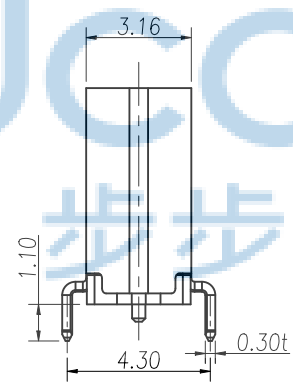
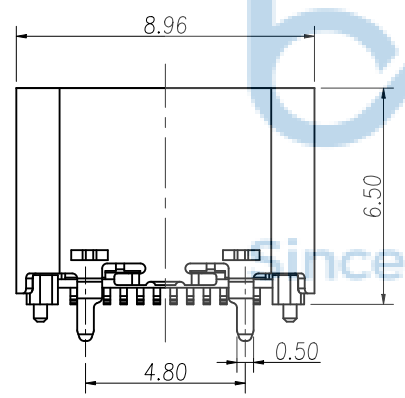
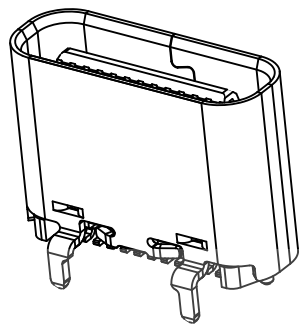
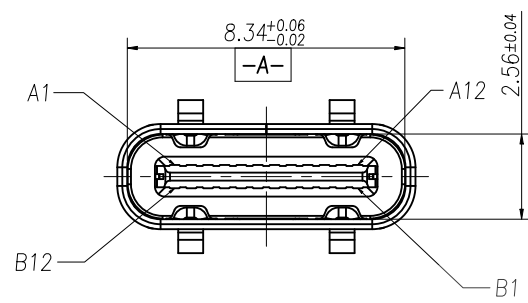

THIS DOCUMENT IS THE SOLE PROPERTY OF BBJconn Technology Co.,Ltd. Corporation AND SHOULD NOT BE USED IN WHOLE OR IN PART WITHOUT PRIOR WRITTEN PERMISSION. PDWG,NO: 0851-1		深圳市步步精科技有限公司	
.X: ±0.38 .XX: ±0.25 .XXX: ±0.13		X': ±3' X'': ±2' X'X': ±1'	
APPD. JM_Zheng	CHKD. LYX	DR. GZY	NAME: TYPE-C 24P 母座 直立式 四脚插 带柱 端子 SMT H=6.50 镀金3u 编带
PJ. NO.: 126-224-240006-M3G		SIZE: A4 DRW NO.:	
FINISH: SEE NOTES		MAT'L.: SEE NOTES	
SCALE: N/A	REV.: A0	UNIT: mm	PAGE: 1/3

REV.	ECN NO	CONTENT	DATE	ENGINEER
A0		Initial release	/	GZY

ASSEMBLY CAP

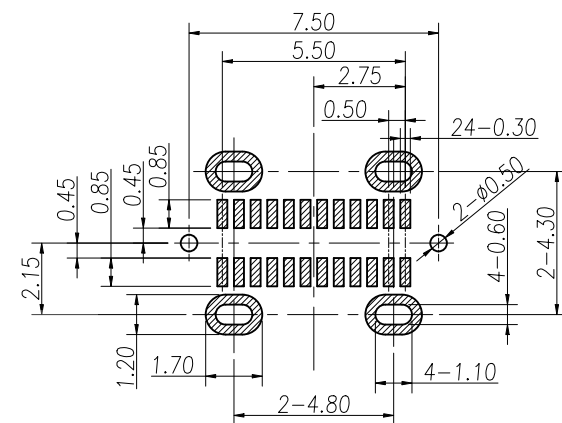
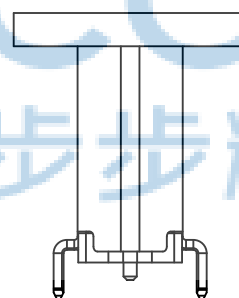
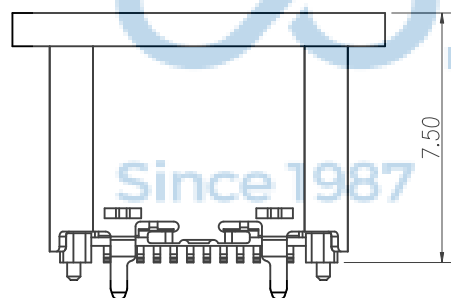
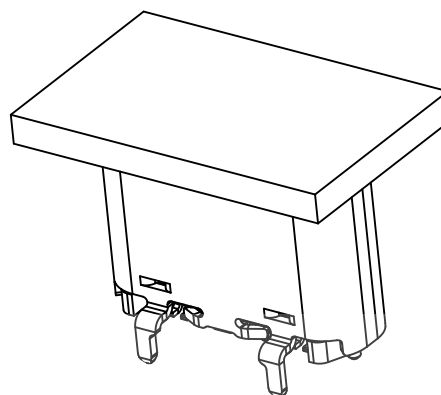
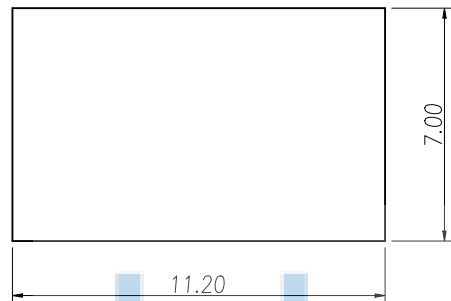

P.C.B LAYOUT VIEW
TOLERANCE ±0.05

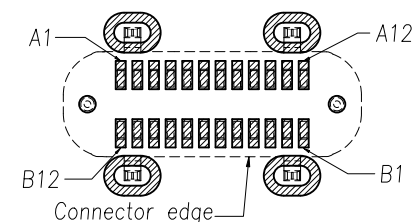

NO.	DESCRIPTION	QTY.	MATERIAL	FINISHED
6	CAP	1 PCS	PLASTIC	UL94V-0
5	MID PLATE	1 PCS	STAINLESS STEEL	None
4	CONTACT 2	1 SET	COPPER ALLOY	CONTACT AREA : Au 3u" Min., Ni 30~80u"
3	CONTACT 1	1 SET	COPPER ALLOY	SOLDER AREA : Matte Tin 50u" Min., Ni 30~80u"
2	HOUSING	1 PCS	PLASTIC	UL94V-0
1	SHELL	1 PCS	STAINLESS STEEL	Ni 50~100u"

THIS DOCUMENT IS THE SOLE PROPERTY OF **BBJconn Technology Co., Ltd.**

深圳市步步精科技有限公司

NAME: TYPE-C 24P 母座 直立式 四脚插 带柱 端子SMT H=6.50 镀金3u 编带

PJ. NO.: 126-224-240006-M3G

SIZE: A4 DRW NO.:

FINISH: SEE NOTES MAT'L.: SEE NOTES

SCALE: N/A REV.: A0 UNIT: mm PAGE: 2/3

APPD. JM_Zheng

CHKD. LYX

DR. GZY

PDWG.NO: 0851-1

PIN ASSIGNMENT												BLADE	SHELL
A1	A2	A3	A4	A5	A6	A7	A8	A9	A10	A11	A12		
GND	TX1+	TX1-	VBUS	CC1	D+	D-	SBU1	VBUS	RX2-	RX2+	GND		
GND	RX1+	RX1-	VBUS	SBU2	D-	D+	CC2	VBUS	TX2-	TX2+	GND	GND	GND
B12	B11	B10	B9	B8	B7	B6	B5	B4	B3	B2	B1		

REV.	ECN NO	CONTENT	DATE	ENGINEER
A0		Initial release	/	GZY

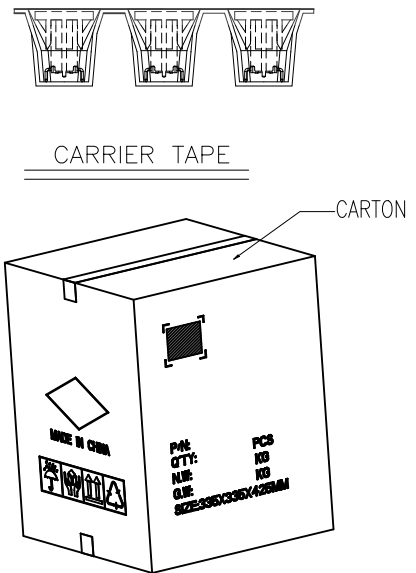
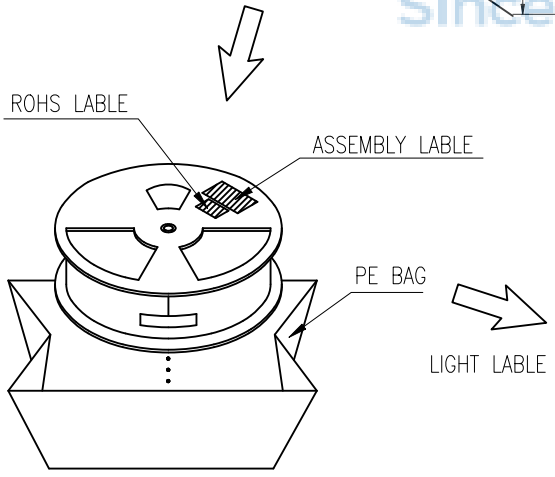
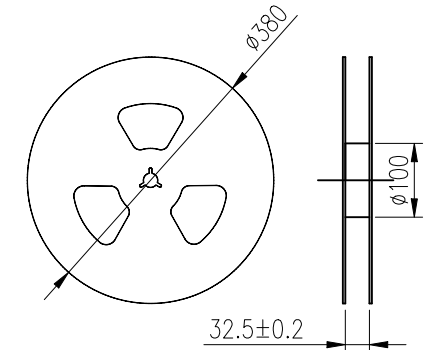
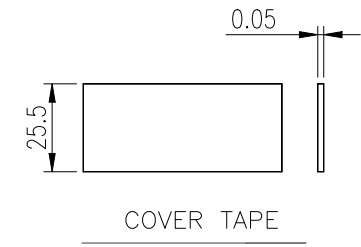
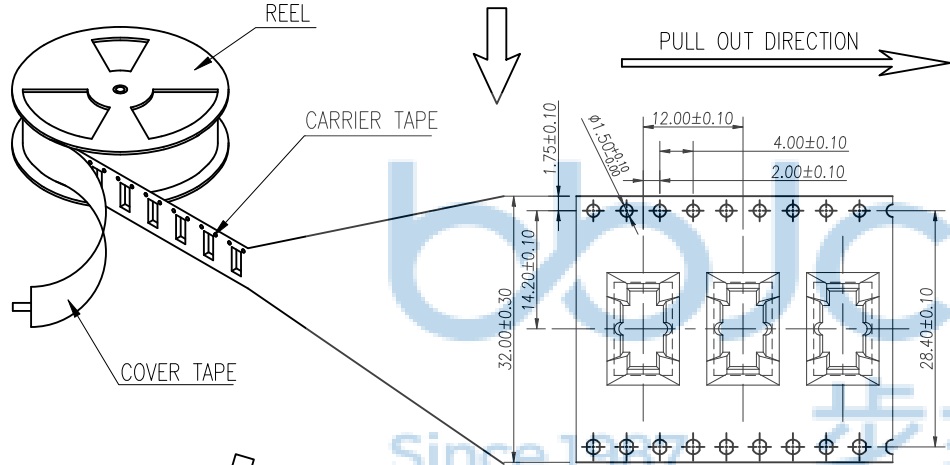
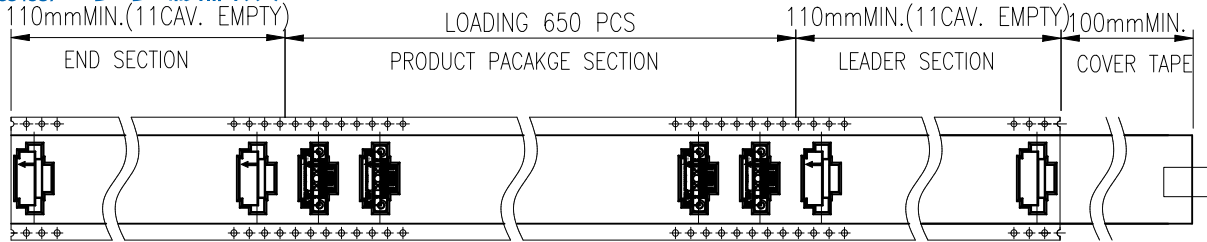

NOTES 2:

- MATERIAL:
 - REEL AND AXLE: PS,BLUE
 - CARRIER TAPE: PET, LUCID
 - COVER TAPE: PS,TRANSPARENT
 - SHIPPING CARTON: CORRUGATED FIBER
- DIMENSION:
 - REEL: W=32.5, φA=380
 - CARRIER TAPE: T=0.50 W=32.0
 - COVER TAPE: T=0.05 W=25.5
 - SHIPPING CARTON: L=386mm, W=386mm, H=425mm
- QUANTITY :
 - PRIMAY PACKING: 650 PCS/REEL
 - SECONARY PACKING: 10 REELS/CARTON(6500PCS/CARTON)
- PEELING RESISTANCE: 0.1~1.3N
 - PEELING SPEED: 300mm/minutes
 - PEELING ANGLE: 165° ~180°



THIS DOCUMENT IS THE SOLE PROPERTY OF BBJconn Technology Co.,Ltd. Corporation AND SHOULD NOT BE USED IN WHOLE OR IN PART WITHOUT PRIOR WRITTEN PERMISSION. PDWG,NO: 0851-1		深圳市步步精科技有限公司	
.X: ±0.38 .XX: ±0.25 .XXX: ±0.13		X': ±3' X'': ±2' X'X': ±1'	
APPD.	JM_Zheng	NAME: TYPE-C 24P 母座 直立式 四脚插 带柱 端子SMT H=6.50 镀金3u 编带	
CHKD.	LYX	PJ. NO.: 126-224-240006-M3G	
DR.	GZY	SIZE: A4 DRW NO.:	
		FINISH: SEE NOTES MAT'L.: SEE NOTES	
		SCALE: N/A REV.: A0 UNIT: mm PAGE: 3/3	