

REV.	ECN NO.	CONTENT	DATE	ENGINEER
A0		Initial release	/	LYL

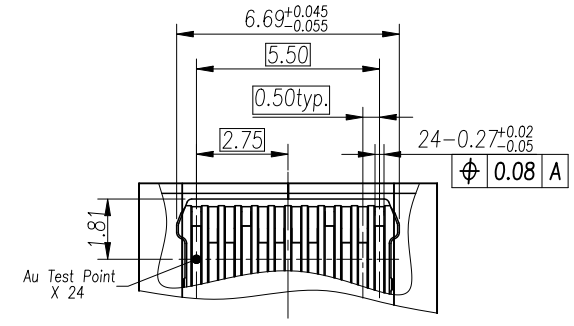

SPECIFICATION:

- ELECTRICAL CHARACTERISTICS:
 - CURRENT RATING: 5A
 - TEMPERATURE RANGE: -40 °C ~ 85 °C
 - CONTACT RESISTANCE: 30 MILLIONHM MAX.
 - DIELECTRIC WITHSTANDING VOLTAGE: 100 VAC r.m.s
 - INSULATION RESISTANCE: 100 MEGOHMS MIN.
- MECHANICAL CHARACTERISTICS
 - INSERTION FORCE: 5~20N
 - EXTRACTION FORCE: Initial:8~20N;
 - DURABILITY:10,000CYCLES
- THE SHELL LENTH IS LESS THAN THE MINIMUM SPECIFIED BY THE USB TYPE C STANDARD,AS SUCH IS CONNOT INDENOENTLY BE GUARANTEED TO MEET ALL TYPE C MECHANICAL REQUIREMENTS.

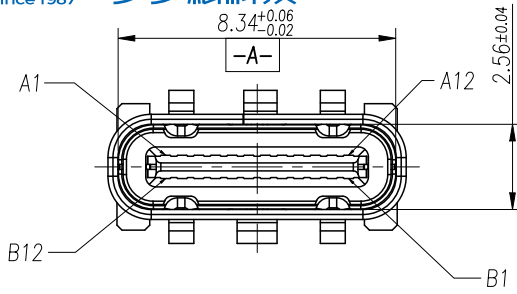
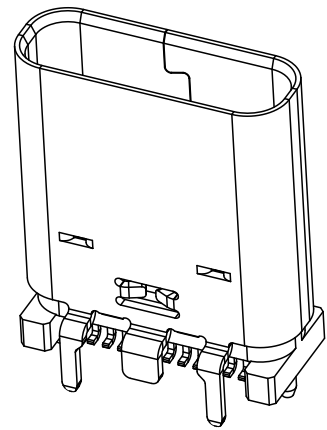
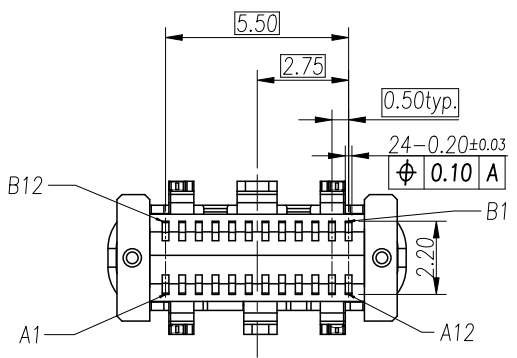
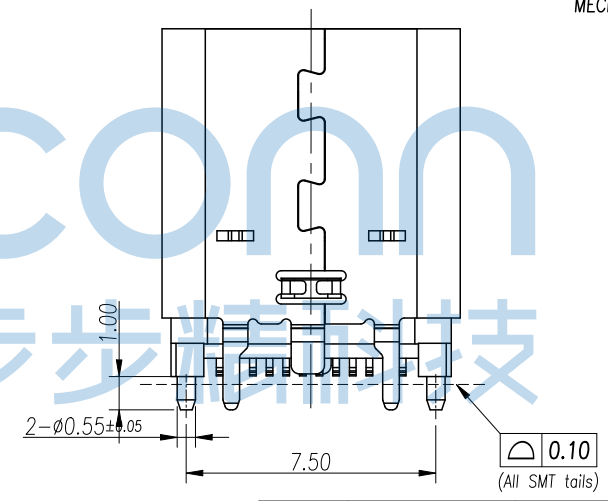
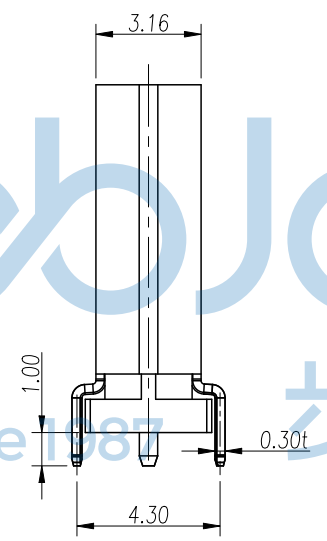
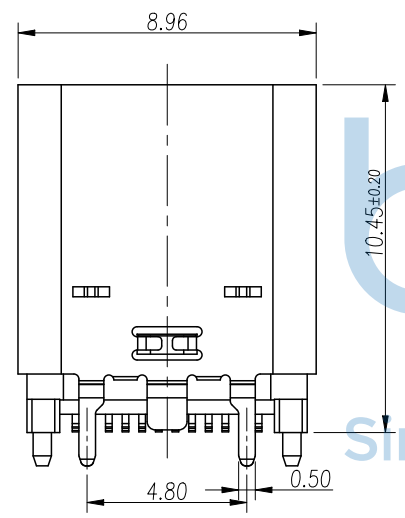

5	MID PLATE	1 PCS	SUS301 T=0.15	None
4	CONTACT 2	1 SET	C7025 T=0.15	Ni 50~100u" Plated; After Au 3u" Plated On Contact Area And Solder Area
3	CONTACT 1	1 SET	C7025 T=0.15	
2	IM HOUSING	1 PCS	LCP BLACK UL94V-0	None
1	SHELL	1 PCS	SUS304 T=0.30	Ni 50~120u" Plated
NO.	DESCRIPTION	QTY.	MATERIAL	FINISHED

THIS DOCUMENT IS THE SOLE PROPERTY OF **BBJconn Technology Co.,Ltd.**
Corporation AND SHOULD NOT BE USED IN WHOLE OR IN PART WITHOUT PRIOR WRITTEN PERMISSION.

深圳市步步精科技有限公司

NAME: TYPE-C 24P 母座 直立式 四脚插 带柱 端子SMT H=10.45 镀金3u" 编带

APPD. JM_Zheng

CHKD. LYX

DR. LYL

PJ. NO.: 126-224-240007-M3G

SIZE: A4 | DRW NO.:

FINISH: SEE NOTES | MAT'L.: SEE NOTES

SCALE: N/A | REV.: A0 | UNIT: mm | PAGE: 1/3

REV.	ECN NO.	CONTENT	DATE	ENGINEER
A0		Initial release	/	LYL

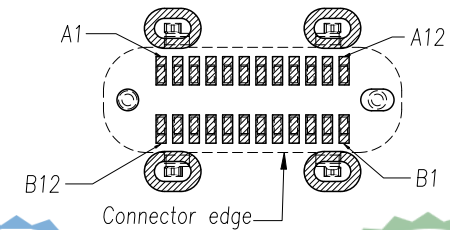
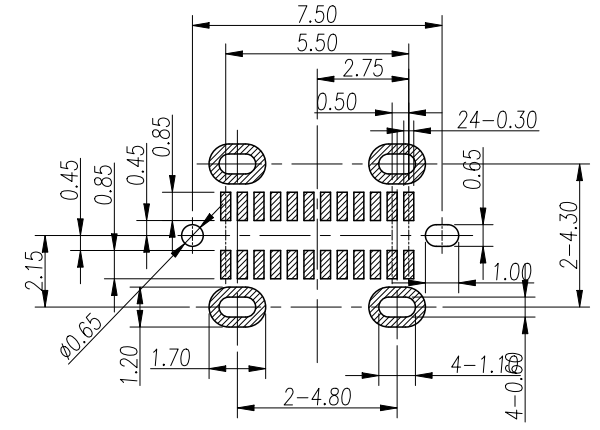
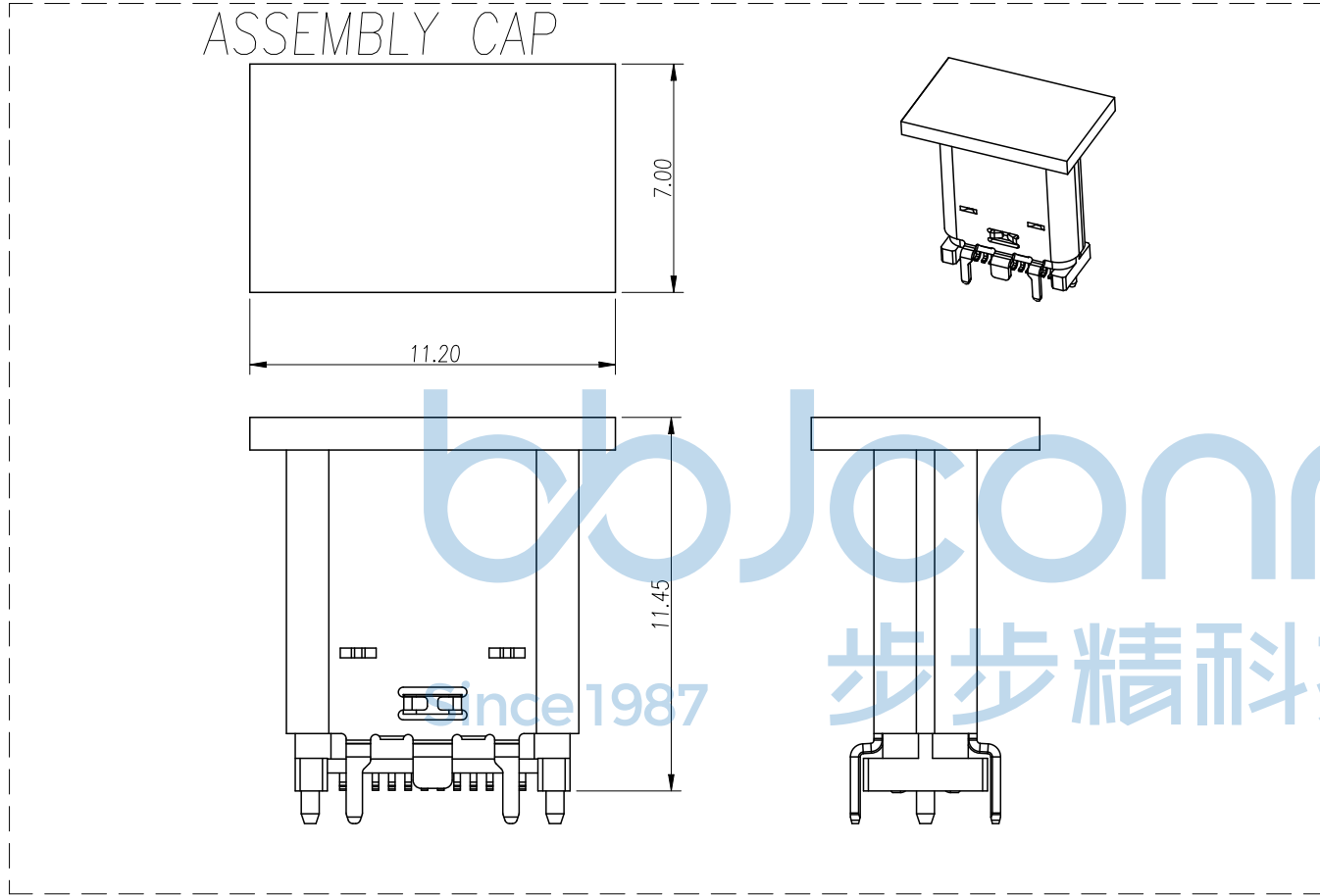

PIN ASSIGNMENT													
A1	A2	A3	A4	A5	A6	A7	A8	A9	A10	A11	A12	BLADE	SHELL
GND	TX1+	TX1-	VBUS	CC1	D+	D-	SBU1	VBUS	RX2-	RX2+	GND	GND	GND
GND	RX1+	RX1-	VBUS	SBU2	D-	D+	CC2	VBUS	TX2-	TX2+	GND		
B12	B11	B10	B9	B8	B7	B6	B5	B4	B3	B2	B1		

THIS DOCUMENT IS THE SOLE PROPERTY OF BBJconn Technology Co., Ltd. Corporation AND SHOULD NOT BE USED IN WHOLE OR IN PART WITHOUT PRIOR WRITTEN PERMISSION.

PDWG.NO: 0851-1

APPD. JM_Zheng
CHKD. LYX
DR. LYL

NAME: TYPE-C 24P 母座 直立式 四脚插 带柱 端子SMT H=10.45 镀金3u" 编带
PJ. NO.: 126-224-240007-M3G
SIZE: A4 | DRW NO.:
FINISH: SEE NOTES | MAT'L.: SEE NOTES
SCALE: N/A | REV.: A0 | UNIT: mm | PAGE: 2/3

深圳市步步精科技有限公司

REV.	ECN NO	CONTENT	DATE	ENGINEER
AO		Initial release	/	LYL

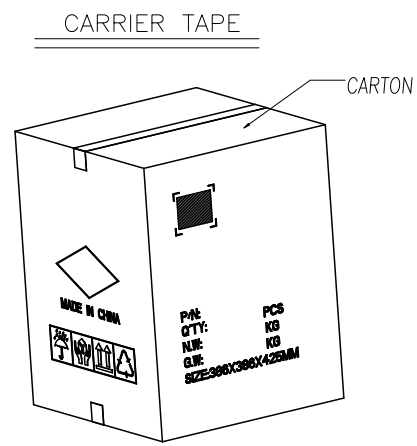
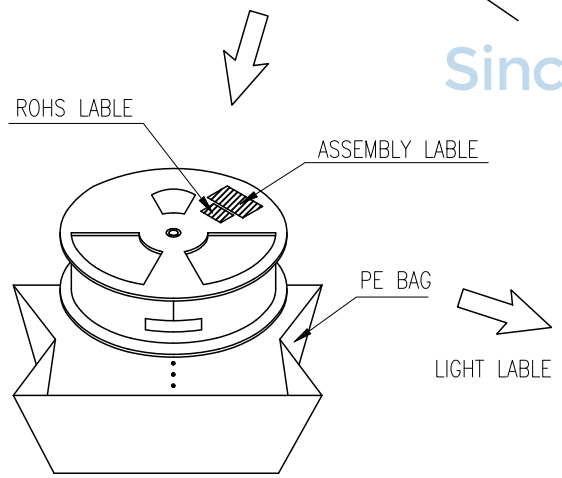
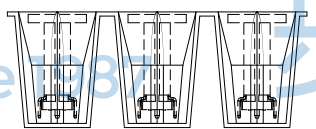
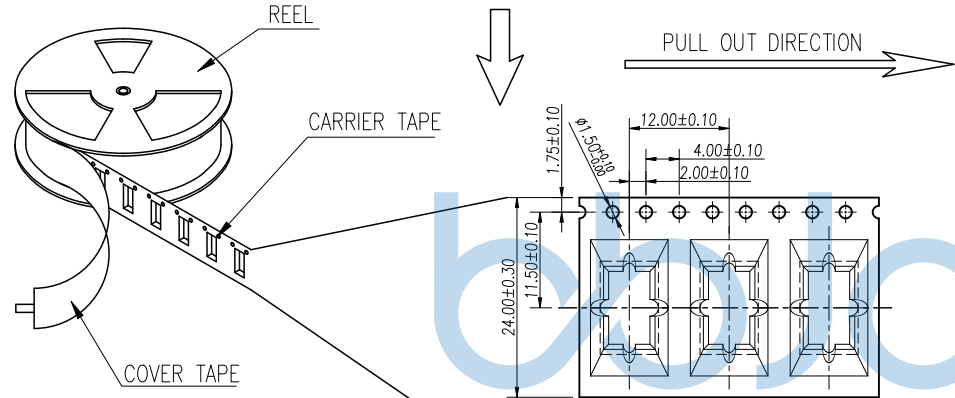
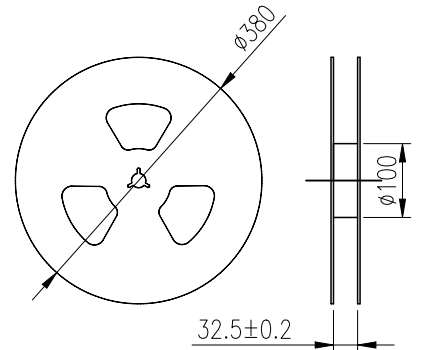
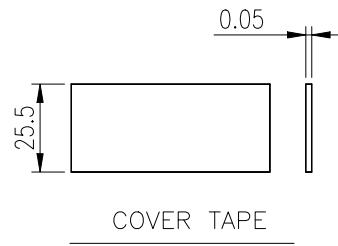
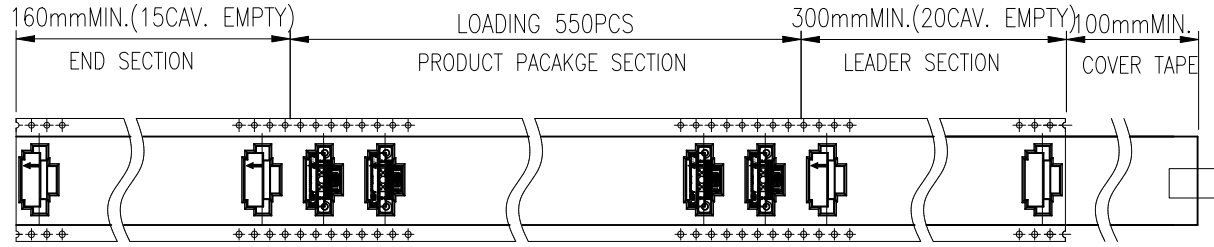

- NOTES 2:
- MATERIAL:
 - 1.1 REEL AND AXLE: PS,BLUE
 - 1.2 CARRIER TAPE: PET, LUCID
 - 1.3 COVER TAPE: PS,TRANSPARENT
 - 1.4 SHIPPING CARTON: CORRUGATED FIBER
 - DIMENSION:
 - 2.1 REEL: W=24.5, φA=380
 - 2.2 CARRIER TAPE: T=0.50 W=24.0
 - 2.3 COVER TAPE: T=0.05 W=21.3
 - 2.4 SHIPPING CARTON: L=386mm, W=386mm, H=425mm
 - QUANTITY:
 - 3.1 PRIMAY PACKING: 550PCS/REEL
 - 3.2 SECONARY PACKING: 12 REELS/CARTON(6600PCS/CARTON)
 - PEELING RESISTANCE: 0.1~1.3N
 - 4.1 PEELING SPEED: 300mm/minutes
 - 4.2 PEELING ANGLE: 165°~180°



THIS DOCUMENT IS THE SOLE PROPERTY OF BBJconn Technology Co.,Ltd. Corporation AND SHOULD NOT BE USED IN WHOLE OR IN PART WITHOUT PRIOR WRITTEN PERMISSION. PDWG.NO: 0851-1		深圳市步步精科技有限公司 .X: ±0.38 .X': ±3' .XX: ±0.25 .X'': ±2' .XXX: ±0.13 .XX': ±1'		NAME: TYPE-C 24P 母座 直立式 四脚插 带柱 端子SMT H=10.45 镀金3u" 编带 APPD. JM_Zheng CHKD. LYX DR. LYL	
		PJ. NO.: 126-224-240007-M3G SIZE: A4 DRW NO.:		FINISH: SEE NOTES MAT'L.: SEE NOTES SCALE: N/A REV.: AO UNIT: mm PAGE: 3/3	