

RECOMMENDED P.C.B Dimension
Tolerances:±0.05mm

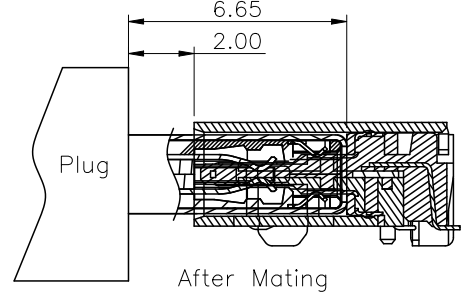

REV	ECN NO	CONTENT	DATE	ENGINEER
A0		INITIAL RELEASE	/	SGF

- 1.MATERIAL:
MOLDING: PA9T UL94 V-0
CONTACT:COPPER ALLOY.
SHELL: SUS304-H,T=0.30±0.03mm
50u" NICKEL PLATING OVER ALL.
SHILD:SUS304-H,T=0.12±0.03mm
- 2.MECHANICAL:
INSERTION: 5~20N.
EXTRACTION: 8~20N.
DURABILITY: 10000 CYCLES
- 3.ELECTRICAL:
CURRENT: 5A MAX FOR VBUS;
1.25A FOR GND,0.25A FOR OTHER OTHER.
VOLTAGE: 20VDC MAX
WITHSTANDING VOLTAGE: 100V AC.
CONTACT RESISTANCE: 40mΩ MAX.
INSULATION RESISTANCE: 100MΩ MIN.
- 4.ENVIRONMENTAL
TEMPERATURE RANGE: -30°C TO +80°C

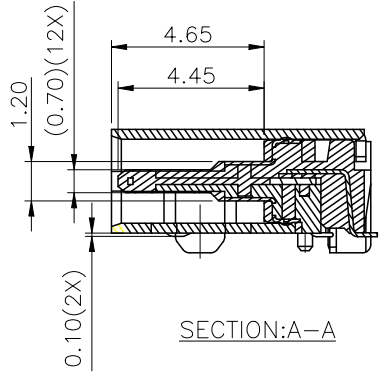
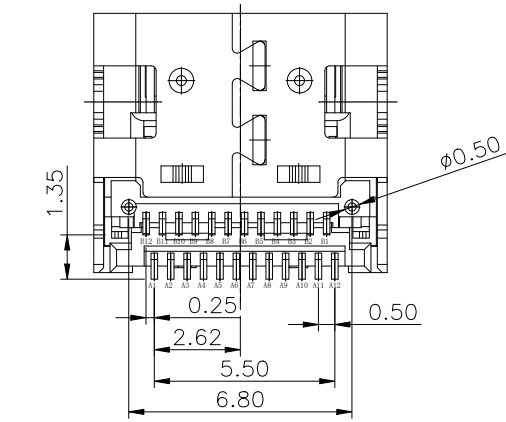
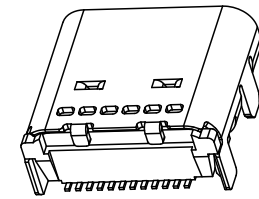

PIN 定义:

PIN NUMBER	SIGNAL NAME	PIN NUMBER	SIGNAL NAME
A1	GND	B12	GND
A2	SSTXp1	B11	SSRXp1
A3	SSTXn1	B10	SSRXn1
A4	Vbus	B9	Vbus
A5	CC1	B8	SBU2
A6	Dp1	B7	Dn2
A7	Dn1	B6	Dp2
A8	SBU1	B5	CC2
A9	Vbus	B4	Vbus
A10	SSRXn2	B3	SSTXn2
A11	SSRXp2	B2	SSTXp2
A12	GND	B1	GND

THIS DOCUMENT IS THE SOLE PROPERTY OF BBJconn Technology Co.,Ltd. Corporation AND SHOULD NOT BE USED IN WHOLE PRIOR WRITTEN PERMISSION.

PDWG NO: 0228-1

深圳市步步精科技有限公司

NAME: TYPE-C 24P 母座 板上四脚插 端子双排SMT 带柱 L=7.90 不锈钢外壳 PA9T蓝胶 编带

PJ NO: 126-221-240004-T7G

SIZE:A4 DRW NO:

FINISH:SEE NOTES MAT'L:SEE NOTES

SCALE:N/A REV:A0 UNIT:mm PAGE:1/3

APPD: JM_Zheng

CHKD: LYX

DR: SGF

REV	ECN NO	CONTENT	DATE	ENGINEER
A0		INITIAL RELEASE	/	SGF

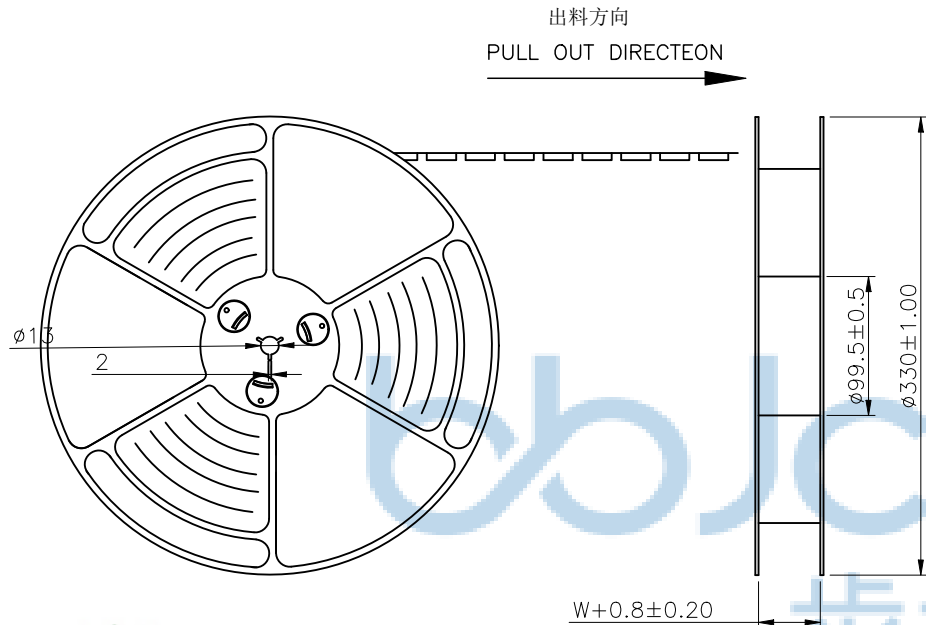

NOTES

- 帶子引導長度
LEAD TAPE LENGTH
出料方向
PULL OUT DIRECTION

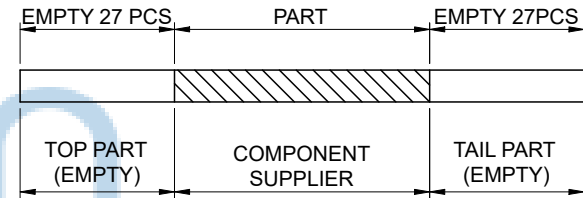

- 上帶 剝力力為: 0.1~1.3N(10.2gf~130gf)
PEELING OFF FORCE OF TOP TAPE: 0.1~1.3N(10.2gf~130gf)
出貨運輸過程中一定注意:
THIS REQUIREMENT SHOULD BE APPLIED AT SHIPMENT:
卷帶在運輸過程中不能散開
PEELING OFF SHOULD NOT BE ALLOWED DURING TRANSPORTATION

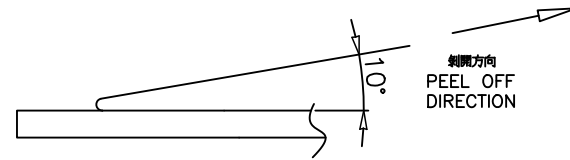
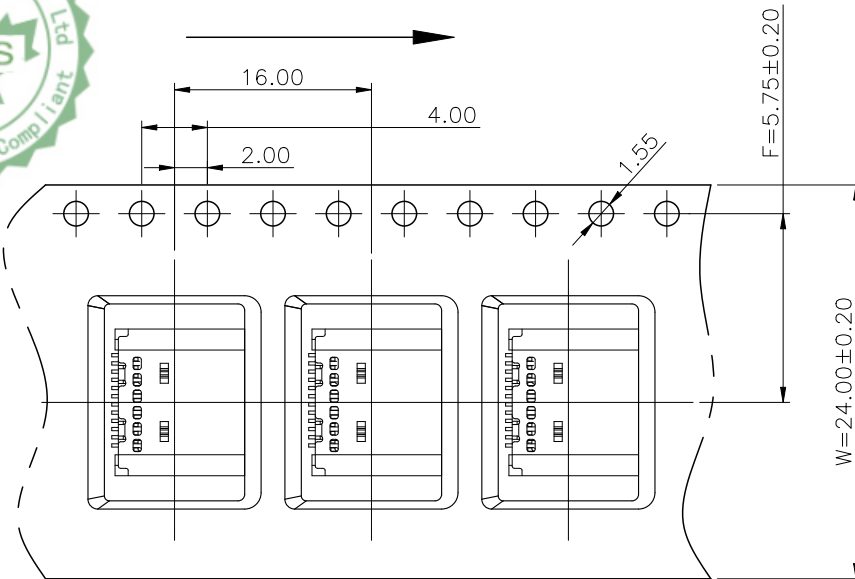

THIS DOCUMENT IS THE SOLE PROPERTY OF BBJconn Technology Co., Ltd. Corporation AND SHOULD NOT BE USED IN WHOLE PRIOR WRITTEN PERMISSION.	bbJconn 深圳市步步精科技有限公司		NAME: TYPE-C 24P 母座 板上四脚插 端子双排SMT 带柱 L=7.90 不锈钢外壳 PA9T蓝胶 编带		
	.X: ±0.38 .XX: ±0.25 .XXX: ±0.13	X': ±3' .X': ±2' .XX': ±1'	APPD	JM_Zheng	PJ NO: 126-221-240004-T7G SIZE:A4 DRW NO:
PDWG NO: 0228-1	CHKD	LYX	DR	SGF	FINISH:SEE NOTES MAT'L:SEE NOTES SCALE:N/A REV:A0 UNIT:mm PAGE:2/3

REV	ECN NO	CONTENT	DATE	ENGINEER
AO		INITIAL RELEASE	/	SGF

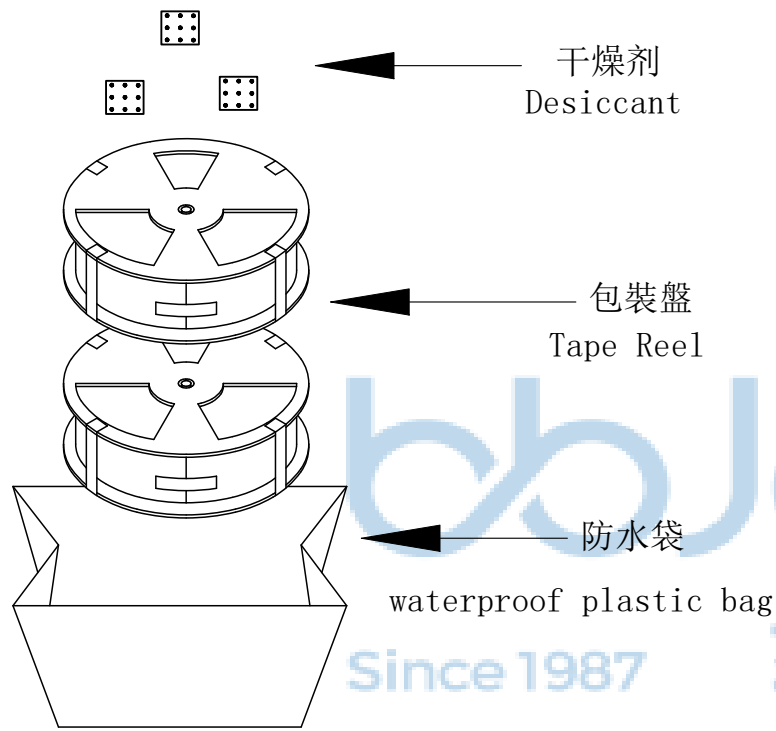

Label pasting location (facing the back of the circular hole on the roll)
标签粘贴处 (朝卷带圆孔反面)

Location of label sticking (label)

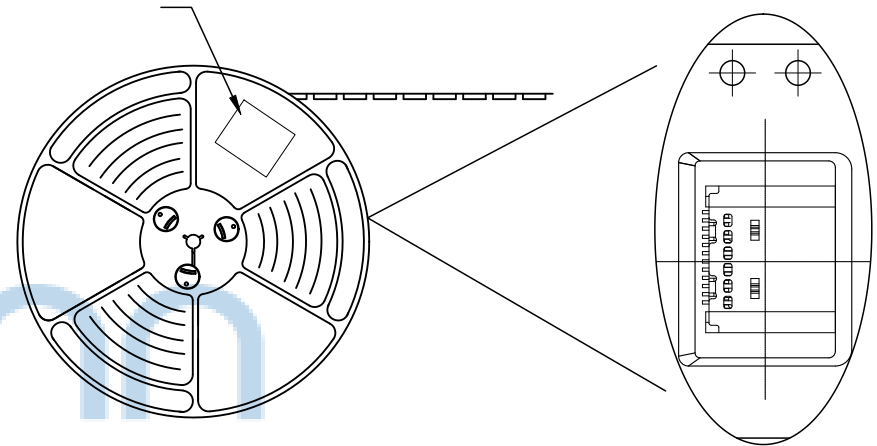

NOTE:
1. 每卷包装数量及每箱装箱数量如左下表格。
Packing q'ty of each reel & carton as below table shown.
2. 以上胶带覆盖下包装带经包装冷封包装
Use cover tape to cover and hot melt machine to seal up.
3. 将装满产品的卷盘放入纸箱并以胶带封口
Put reels in the carton and use adhesive tape to seal up.

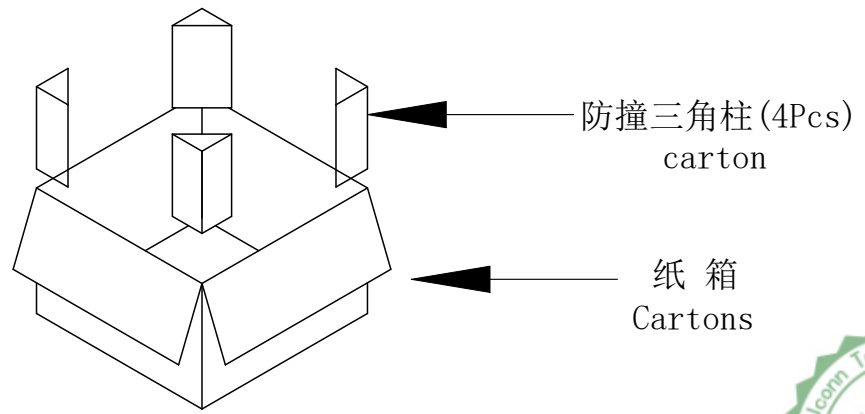

包装数量(PACKING CAPACITY)			重量 WEIGHT (Kg)		
PCS/REEL	REELS/CARTON	PCS/CARTON	N.W./PCS	N.W./BOX	G.W./BOX
900	10	9000			

THIS DOCUMENT IS THE SOLE PROPERTY OF BBJconn Technology Co.,Ltd. Corporation AND SHOULD NOT BE USED IN WHOLE PRIOR WRITTEN PERMISSION.		PDWG NO: 0228-1		DR SGF		深圳市步步精科技有限公司 NAME: TYPE-C 24P 母座 板上四脚插 端子双排SMT 带柱 L=7.90 不锈钢外壳 PA9T蓝胶 编带 APPD JM_Zheng CHKD LYX PJ NO: 126-221-240004-T7G SIZE:A4 DRW NO: FINISH:SEE NOTES MAT'L:SEE NOTES SCALE:N/A REV:A0 UNIT:mm PAGE:3/3	
---	--	-----------------	--	--------	--	---	--