

REV.	ECN NO	CONTENT	DATE	ENGINEER
A0		Initial release	/	TSP

NOTES:

- MATERIAL:**  
MOLDING: LCP UL94 V-0  
CONTACT: COPPER ALLOY.  
  
SHELL: SUS304-H, T=0.30±0.03mm  
50u" NICKEL PLATING OVER ALL.  
SHILD: SUS304-H, T=0.12±0.03mm
- MECHANICAL:**  
INSERTION: 5~20N.  
EXTRACTION: 8~20N.  
DURABILITY: 10000 CYCLES
- ELECTRICAL:**  
CURRENT: 5A MAX FOR VBUS;  
1.25A MAX FOR OTHER.  
VOLTAGE: 20VDC MAX  
WITHSTANDING VOLTAGE: 100V AC.  
CONTACT RESISTANCE: 40mΩ MAX.  
INSULATION RESISTANCE: 100MΩ MIN.
- ENVIRONMENTAL**  
TEMPERATURE RANGE: -30° C TO +80° C

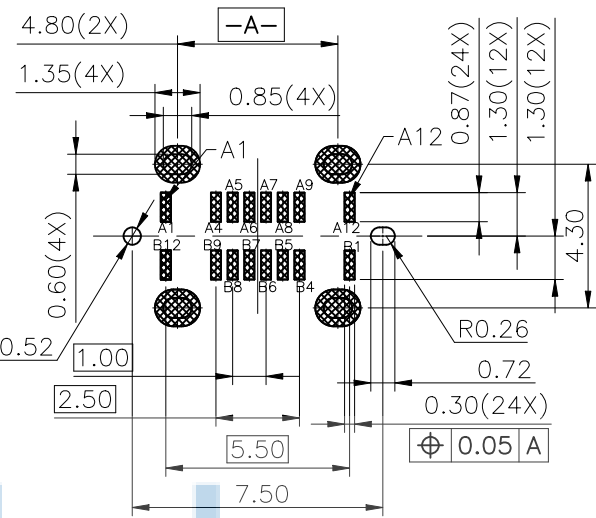

**RECOMMENDED PCB LAYOUT(TOP VIEW)**  
TOLERANCE UNSPECIFIED ±0.05mm

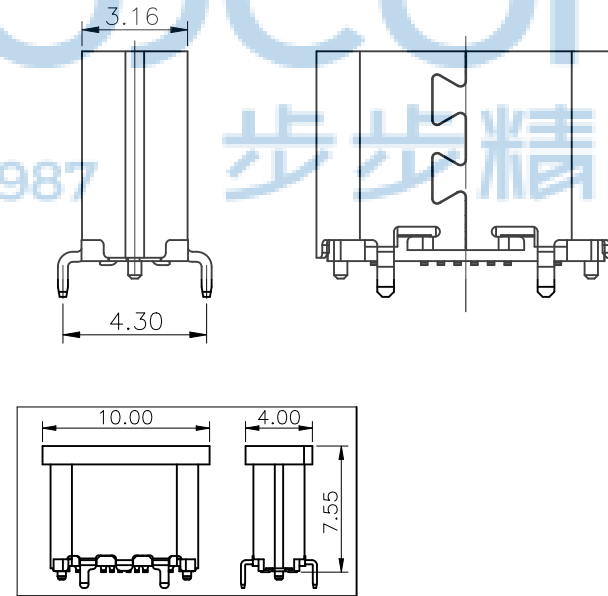
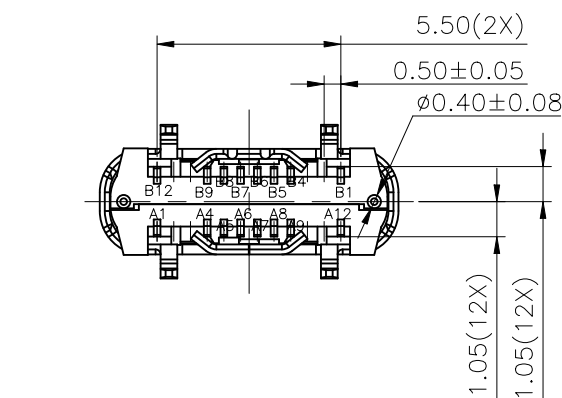
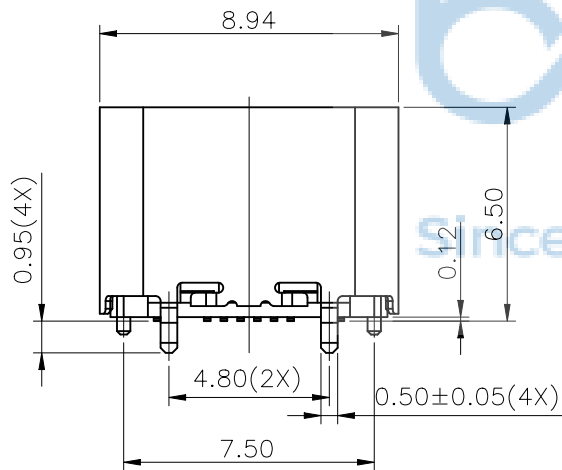
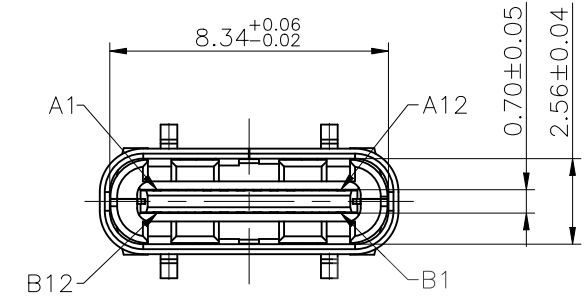

A1	GND	B12	GND
A4	VBUS	B9	VBUS
A5	CC1	B8	SBU2
A6	DP1	B7	DN2
A7	DN1	B6	DP2
A8	SBU1	B5	CC2
A9	VBUS	B4	VBUS
A12	GND	B1	GND
PIN	SIGNAL NAME	PIN	SIGNAL NAME

THIS DOCUMENT IS THE SOLE PROPERTY OF BBJconn Technology Co.,Ltd. Corporation AND SHOULD NOT BE USED IN WHOLE OR IN PART WITHOUT PRIOR WRITTEN PERMISSION.

PDWG.NO: 0366-2

APPD. JM\_Zheng  
CHKD. LYX  
DR. TSP

**深圳市步步精科技有限公司**  
NAME: TYPE-C 16P 母座 直立式  
SMT 四脚插 带柱 H=6.50  
PJ. NO.: 126-224-160001-T7G  
SIZE: A4 DRW NO.:  
FINISH: SEE NOTES MAT'L.: SEE NOTES  
SCALE: N/A REV.: A0 UNIT: mm PAGE: 1/3

REV.	ECN NO	CONTENT	DATE	ENGINEER
A0		Initial release	/	TSP

出料方向  
PULL OUT DIRECTEON

NOTES

1. 帶子引導長度  
LEAD TAPE LENGTH  
出料方向  
PULL OUT DIRECTEON

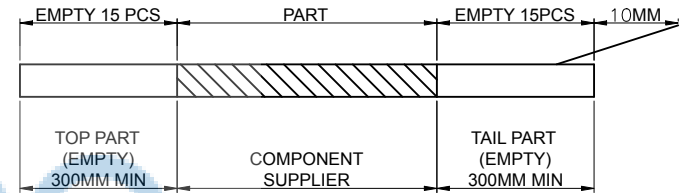
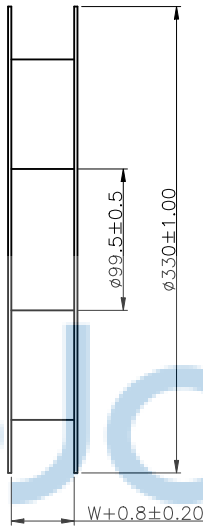
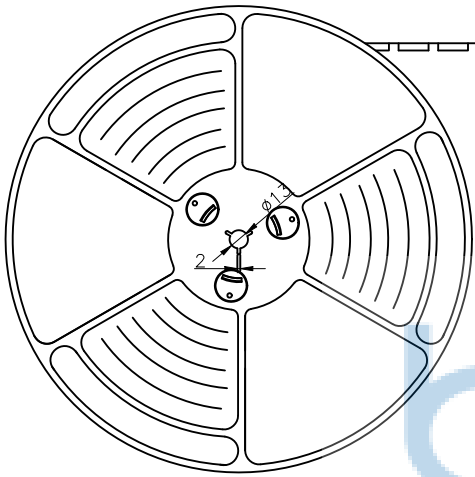

2. 上帶 剝力為 : 0.1~1.3N(10.2gf~130gf)  
PEELING OFF FORCE OF TOP TAPE: 0.1~1.3N(10.2gf~130gf)

出貨運輸過程中一定注意:  
THIS REQUIREMENT SHOULD BE APPLIED AT SHIPMENT:  
卷帶在運輸過程中不能散開  
PEELING OFF SHOULD NOT BE ALLOWED DURING TRANSPORTATION

Since 1987

步步精科技

出料方向

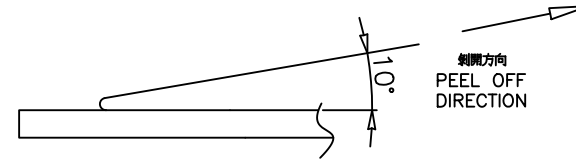
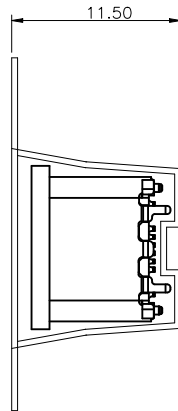
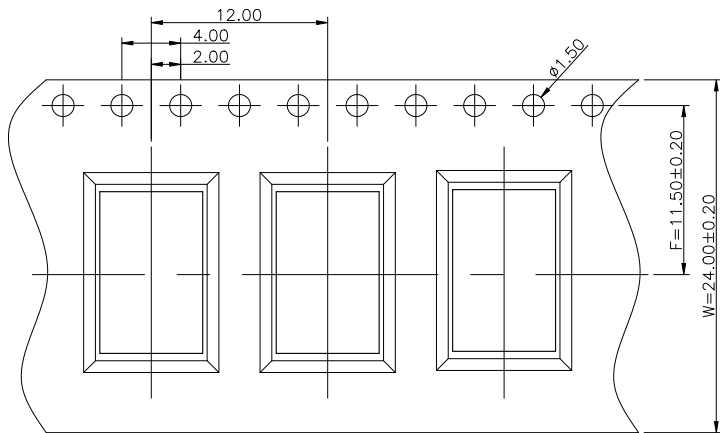

THIS DOCUMENT IS THE SOLE PROPERTY OF BBJconn Technology Co., Ltd. Corporation AND SHOULD NOT BE USED IN WHOLE OR IN PART WITHOUT PRIOR WRITTEN PERMISSION.		<b>深圳市步步精科技有限公司</b>	
.X: ±0.38 .XX: ±0.25 .XXX: ±0.13		X': ±3' .X': ±2' .XX': ±1'	
APPD.	JM_Zheng	NAME: TYPE-C 16P 母座 直立式 SMT 四脚插 带柱 H=6.50	
CHKD.	LYX	PJ. NO.: 126-224-160001-T7G	
DR.	TSP	SIZE: A4 DRW NO.:	
PDWG.NO: 0366-2		FINISH: SEE NOTES MAT'L.: SEE NOTES	
		SCALE: N/A REV.: A0 UNIT: mm PAGE: 2/3	

REV.	ECN NO	CONTENT	DATE	ENGINEER
A0		Initial release	/	TSP

Location of label sticking (label)

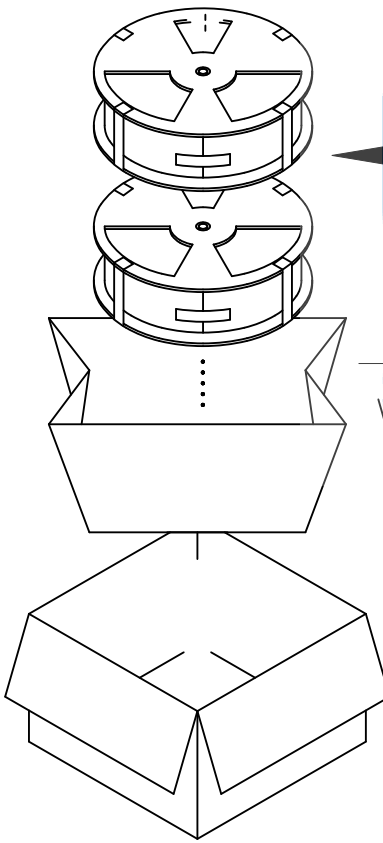
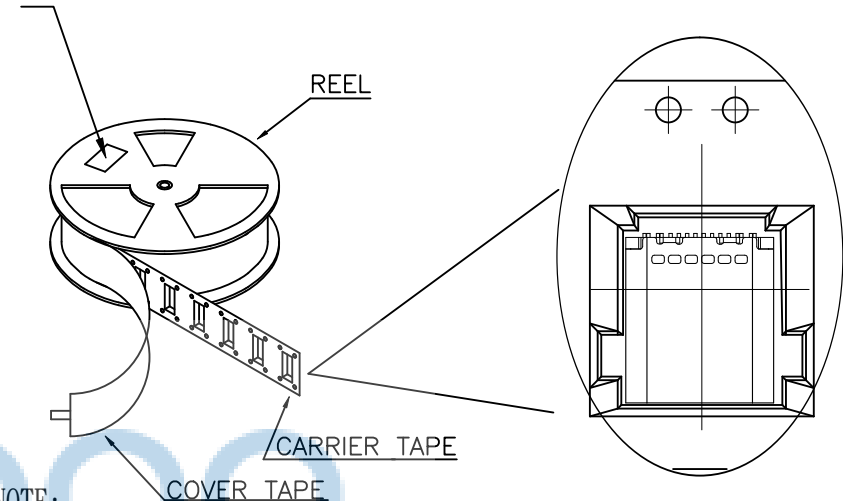

tape reel

waterproof plastic bag

carton

NOTE:

1. 每捲包裝數量及每箱裝箱數量如左下表格。  
Packing q'ty of each reel & carton as below table shown.
2. 以上膠帶覆蓋下包裝帶經包裝機熱熔包裝  
Use cover tape to cover and hot melt machine to seal up.
3. 每個紙箱放2個珍珠棉  
Every carton use 2pcs EPE.
4. 將裝滿產品的卷盤放入紙箱并以膠帶封口  
Put reels in the carton and use adhesive tape to seal up.



產品料號 (PRODUCT No.)	包裝容量 (PACKING CAPACITY)			重量 WEIGHT (Kg)		
	PCS/REEL	REELS/CARTON	PCS/CARTON	N.W./PCS	N.W./BOX	G.W./BOX
	600	10	6000			

THIS DOCUMENT IS THE SOLE PROPERTY OF BBJconn Technology Co.,Ltd. Corporation AND SHOULD NOT BE USED IN WHOLE OR IN PART WITHOUT PRIOR WRITTEN PERMISSION.		深圳市步步精科技有限公司 .X: ±0.38    .X': ±3" .XX: ±0.25    .X': ±2" .XXX: ±0.13    .XX': ±1"		NAME: TYPE-C 16P 母座 直立式 SMT 四脚插 带柱 H=6.50 PJ. NO.: 126-224-160001-T7G SIZE: A4   DRW NO.:	
APPD.	JM_Zheng			FINISH: SEE NOTES    MAT'L.: SEE NOTES	
CHKD.	LYX	PDWG.NO: 0366-2		SCALE: N/A    REV.: A0    UNIT: mm    PAGE: 3/3	
DR.	TSP				