

REV.	ECN NO	CONTENT	DATE	ENGINEER
A0			2023 20/04	

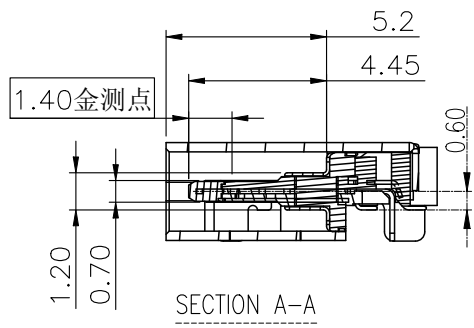

- MATERIAL:**
MOLDING: LCP UL94 V-0
CONTACT: COPPER ALLOY.
PLATED GOLD ON CONTACT AREA,
G/F GOLD ON SOLDER AREA,
50u" NICKEL PLATING OVER ALL.
SHELL: SUS304-H, T=0.30±0.03mm
50u" NICKEL PLATING OVER ALL.
EMI SHILD: SUS304-H, T=0.12±0.03mm
LATCH: SUS301-H, T=0.15±0.03mm
- MECHANICAL:**
INSERTION: 5~20N.
EXTRACTION: 8~20N.
DURABILITY: 10000 CYCLES
- ELECTRICAL:**
CURRENT: 5A MIN FOR VBUS;
0.25A MIN FOR OTHER.
VOLTAGE: 5VAC MAX
WITHSTANDING VOLTAGE: 100V AC.
CONTACT RESISTANCE: 40mΩ MAX.
INSULATION RESISTANCE: 100MΩ MIN.
- ENVIRONMENTAL**
TEMPERATURE RANGE: -30° C TO +80° C

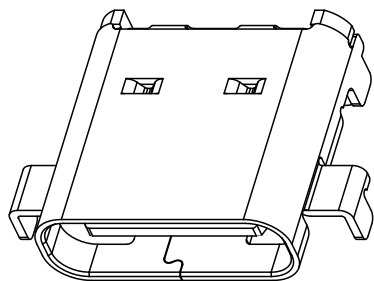
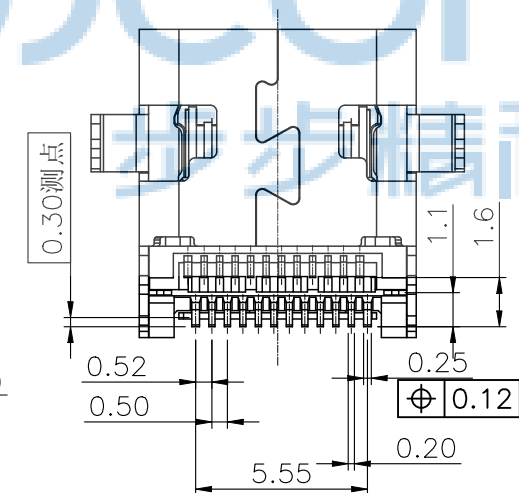
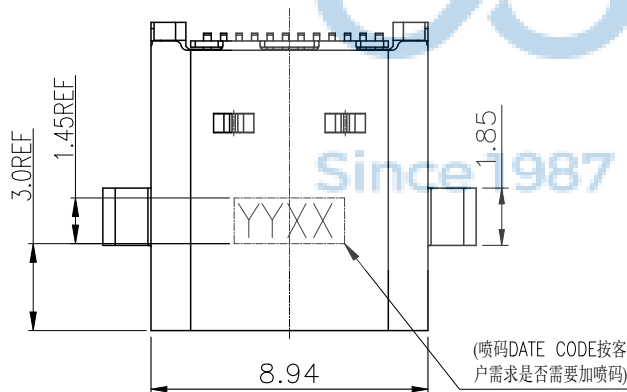
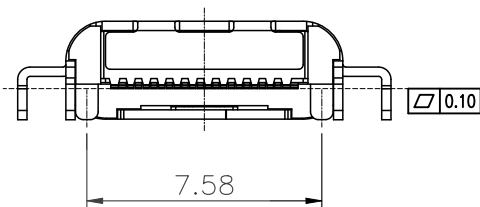
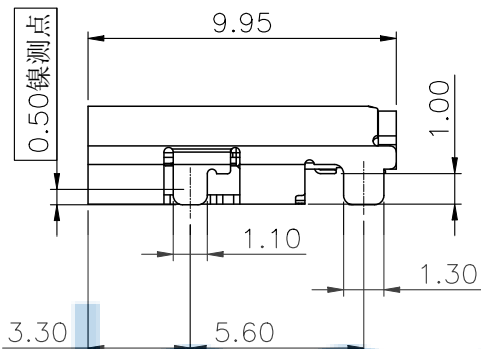
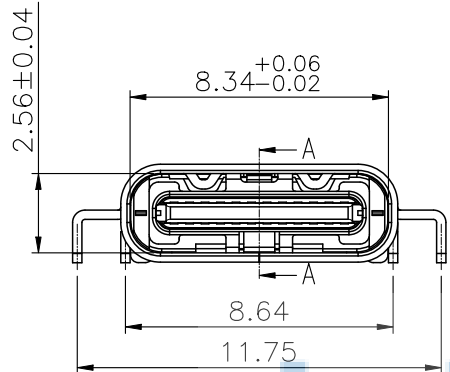

THIS DOCUMENT IS THE SOLE PROPERTY OF BBJconn Technology Co., Ltd. Corporation AND SHOULD NOT BE USED IN WHOLE OR IN PART WITHOUT PRIOR WRITTEN PERMISSION. PDWG.NO: 0228-1	深圳市步步精科技有限公司 .X: ±0.38 .X': ±3" .XX: ±0.25 .X'': ±2" .XXX: ±0.13 .XX': ±1"		NAME:	
			TYPE-C 24P 母座 四脚插 L=9.95 CH=0.60 沉板1.0 端子双排SMT 单壳	
	APPD. JM_Zheng 23/05'02	PJ. NO.: 126-221-240005-J4G SIZE: A4 DRW NO.:	FINISH: SEE NOTES MAT'L.: SEE NOTES	
	CHKD. LYX 23/05'02		SCALE: N/A REV.: A3 UNIT: mm PAGE: 1/1	
DR. LHC 23/05'02				

USB TYPE-C PIN ASSIGNMENTS

PIN NUMBER	SIGNAL NAME	PIN NUMBER	SIGNAL NAME
A1	GND	B12	GND
A2	SSTXp1	B11	SSRXp1
A3	SSTXn1	B10	SSRXn1
A4	VBUS	B9	VBUS
A5	CC1	B8	SBU2
A6	Dp1	B7	Dn2
A7	Dn1	B6	Dp2
A8	SBU1	B5	CC2
A9	VBUS	B4	VBUS
A10	SSRXn2	B3	SSTXn2
A11	SSRXp2	B2	SSTXp2
A12	GND	B1	GND

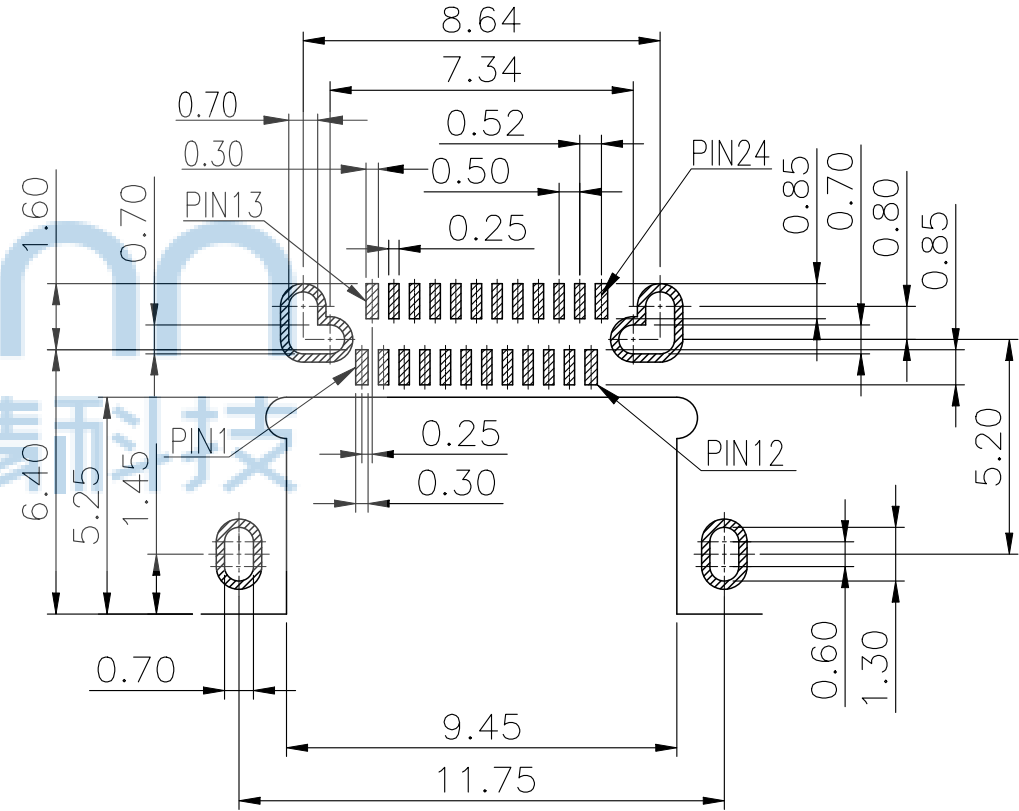

RECOMMENDED PCB LAYOUT



THIS DOCUMENT IS THE SOLE PROPERTY OF BBJconn Technology Co.,Ltd. Corporation AND SHOULD NOT BE USED IN WHOLE OR IN PART WITHOUT PRIOR WRITTEN PERMISSION.		深圳市步步精科技有限公司	
APPD.	JM_Zheng	23/05'02	NAME: TYPE-C 24P 母座 四脚插 L=9.95 CH=0.60 沉板1.0 端子双排SMT 单壳
CHKD.	LYX	23/05'02	PJ. NO.: 126-221-240005-J4G
DR.	LHC	23/05'02	SIZE: A4 DRW NO.:
PDWG.No: 0228-1		FINISH: SEE NOTES MAT'L.: SEE NOTES	
		SCALE: N/A REV.: A3 UNIT: mm PAGE: 1/1	

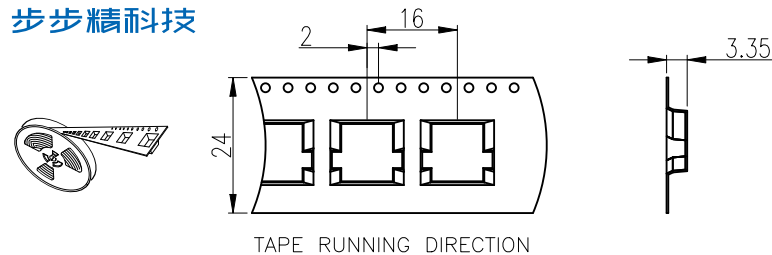

第一步: 产品摆入载带中(应注意产品摆放方向和载带拉出方向要正确)

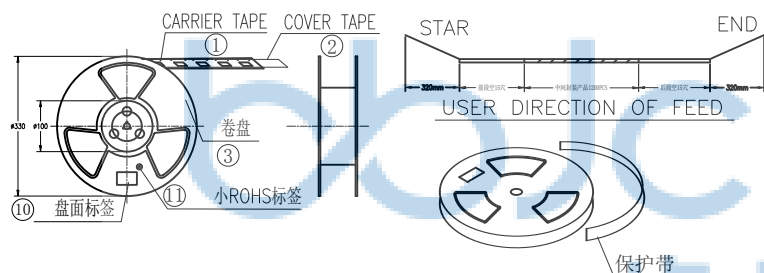

第二步: 封带贴标签(应注意封带不能盖孔不能超边, 标签位置正确)

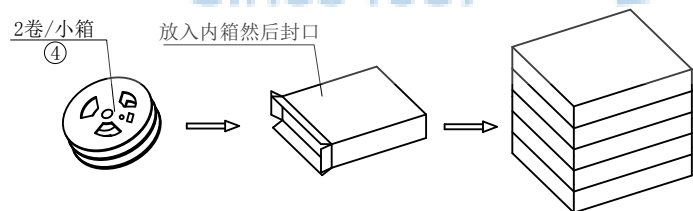

第三步: 装内箱封口(应注意卷盘标签面朝上, 封口整齐)

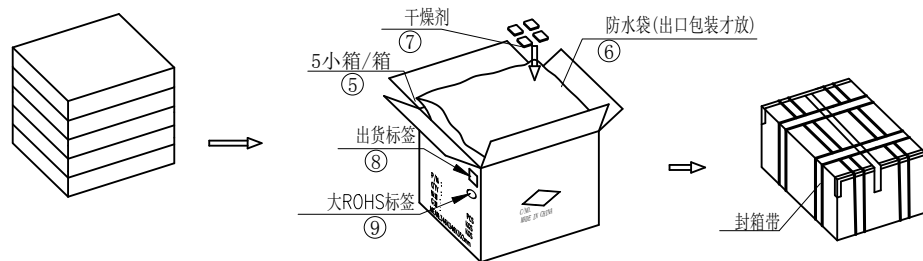

第四步: 装外箱贴标签(应注意封口整齐, 标签位置正确)

- NOTE: 1. 如图所示, 将成品按规定之包装数量置入CARRIER TAPE中, 再将COVER TAPE贴合, 并于卷盘上贴上盘面标签和ROHS标签各一张。
 2. 每2卷装入一小箱, 计2400PCS/小箱;
 3. 每5小箱装入一外箱内, 每箱置四袋干燥剂, 共. 12000PCS/箱;
 4. 纸箱封盖后以封箱胶封箱, 并于侧面贴上出货标签和ROHS标签;
 5. 标签;若客户另有贴标签要求, 则按其订单注明之要求贴;
 6. 外箱以封箱带绑固;若为出口包装, 请在每箱内套一防水袋。
 7. 纸箱尺寸及印刷见包材图面。
 未满足之零数箱, 需以缓冲材料填满。(总毛重仅作参考, 出货以实称为准)
 8. 本包装方式适用产品: USB C TYPE 3.1沉板母座

产品数量	产品单重	产品净重	参考总毛重
12000PCS	0.595g		



⑪	小ROHS标签	10	PCS	Ø15.7
⑩	盘面标签	10	PCS	
⑨	大ROHS标签	1	PCS	Ø40.0
⑧	出货标签	1	PCS	
⑦	干燥剂	5	BAG	
⑥	防水袋	1	PCS	
⑤	外纸箱	1	PCS	346*346*352 K=K 内径
④	内纸箱	5	PCS	332*332*61mm A3B 内径
③	卷盘	10	SET	Ø330*100mm, W=24mm
②	COVER TAPE	1200	10	PCS W=21.3mm, 20.3M/REEL
①	CARRIER TAPE			W=24mm, T=0.30mm, 19.7M/REEL
序号	包材名称	PCS/盘	盘/箱	单位 备注
		包装总数量		



THIS DOCUMENT IS THE SOLE PROPERTY OF BBJconn Technology Co., Ltd. Corporation AND SHOULD NOT BE USED IN WHOLE OR IN PART WITHOUT PRIOR WRITTEN PERMISSION. PDWG.No: 0228-1		深圳市步步精科技有限公司 NAME: TYPE-C 24P 母座 四脚插 L=9.95 CH=0.60 沉板1.0 端子双排SMT 单壳 APPD. JM_Zheng 23/05'02 CHKD. LYX 23/05'02 DR. LHC 23/05'02 PJ. NO.: 126-221-240005-J4G SIZE: A4 DRW NO.: FINISH: SEE NOTES MAT'L.: SEE NOTES SCALE: N/A REV.: A3 UNIT: mm PAGE: 1/1	
---	--	--	--