

REV.	ECN NO	CONTENT	DATE	ENGINEER
AO				

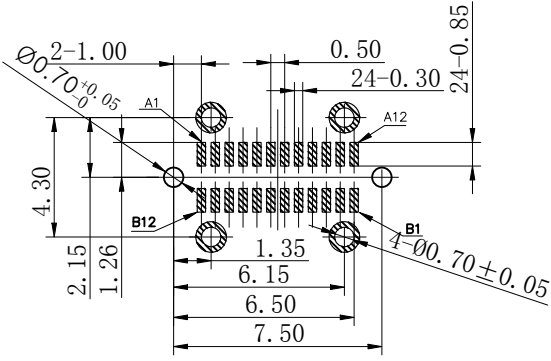

RECOMMENDED 公差±0.05C.B LAYOUT

- NOTE:
- MATERIAL:
    - INSULATOR: HIGH TEMPERATURE PLASTIC UL 94 V-0;LCP
    - CONTACT: COPPER ALLOY
    - SHELL:STAINLESS STEEL
  - ELECTRICAL CHARACTERISTICS;
    - CONTACT RESISTANCE: 40mΩ Max FOR INITIAL. 30mΩ CHANGE AFTER TEST. MEASURE AT 20mV, 100mA.
    - CONTACT CURRENT RATING: 5A FOR VBUS PIN; 1.25A FOR VCONN PIN.
    - DIELECTRIC WITHSTANDING VOLTAGE: 100V AC R.M.S.
    - INSULATION RESISTANCE 100MΩ Min
    - OPERATING TEMPERATURE: -40°C ~ 85°C
  - MECHANICAL CHARACTERISTICS:
    - MATING FORCE: 5~20 N.
    - UNMATED FORCE: 8~20N AFTER TEST
    - DURABILITY: 10,000 CYCLES
  - PLATING
    - TERMINAL CONTACT: (SEE TAB) GOLD PLATING ALL OVER 50u" Min NICKEL AND 80u"Min Tin ALL OVER 50u" Min NICKEL ON SOLDER AREA
    - SHELL: 50u" Min. NICKEL ALL OVER,

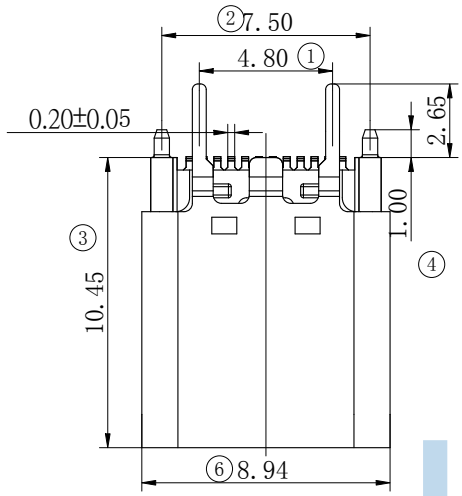
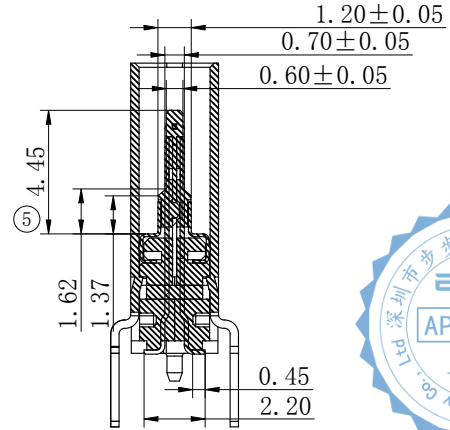
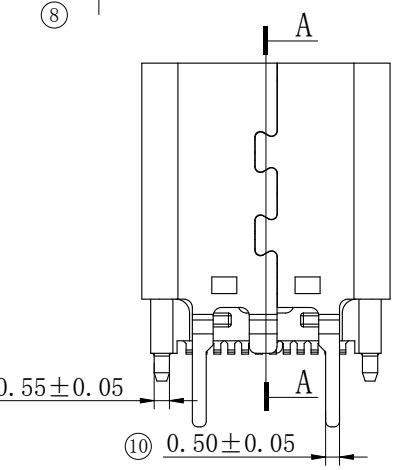
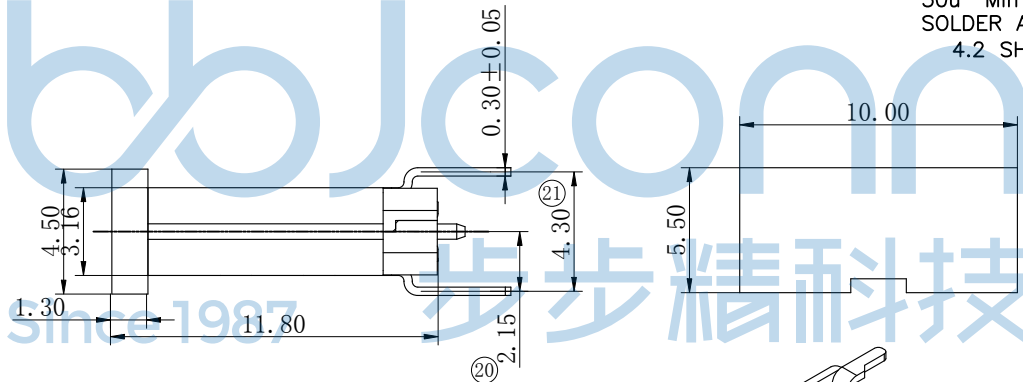
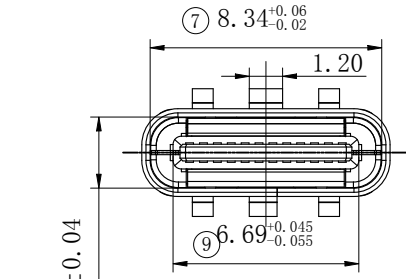

SECTION "A-A"

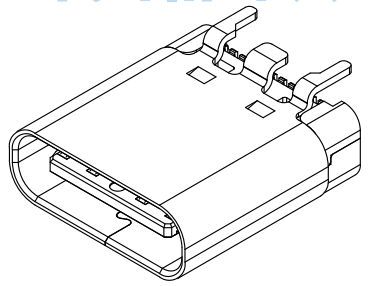

THIS DOCUMENT IS THE SOLE PROPERTY OF BBJconn Technology Co.,Ltd. Corporation AND SHOULD NOT BE USED IN WHOLE OR IN PART WITHOUT PRIOR WRITTEN PERMISSION.		深圳市步步精科技有限公司 .X: ±0.38    .X': ±3" .XX: ±0.25    .X'': ±2" .XXX: ±0.13    .X'X': ±1"		NAME:TYPE-C 24P 母座 直立式 四脚插 带柱 H=10.50 端子SMT 外壳脚长2.65 (C-TF419-LH47XXY)	
APPD.	JM_Zheng	PJ. NO.: 126-224-240001-J6G		SIZE: A4   DRW NO.:	
CHKD.	LYX	FINISH: SEE NOTES		MAT'L.: SEE NOTES	
PDWG.NO:	0469-2	DR.	LHC	SCALE: N/A	REV.: AO   UNIT: mm   PAGE: 1/2

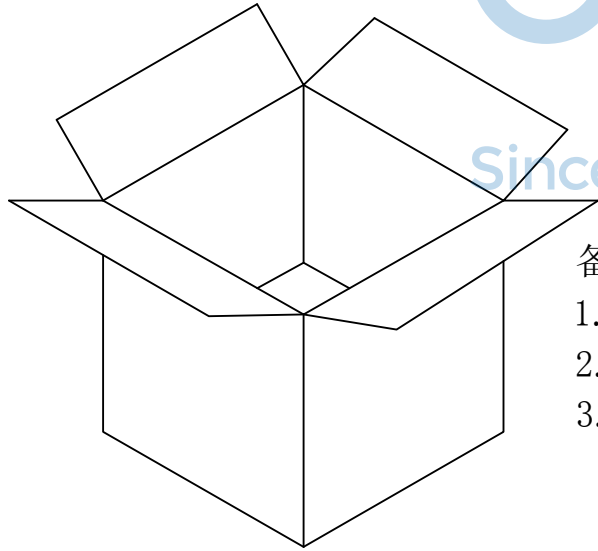
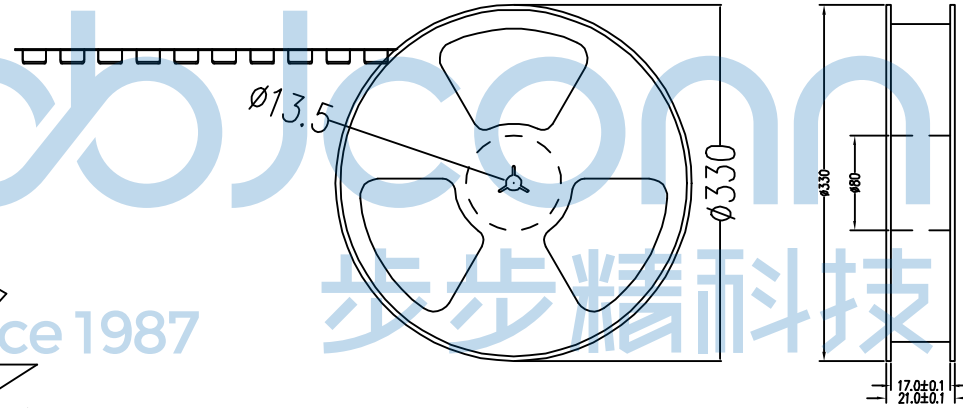
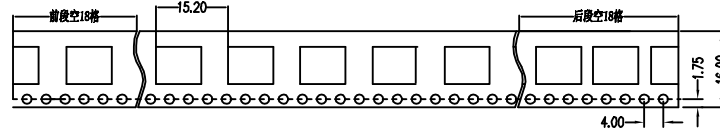
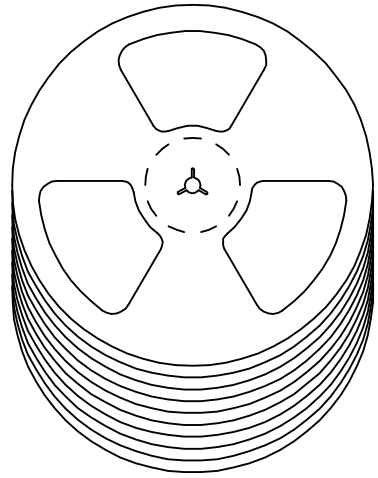

备注:

1. 包装数量: 270 /PCS/卷, 10卷/箱。
2. 包装袋长度: 每卷前后各空10-20个空格, 中间包装。
3. 材质:  
 载体: 聚丙烯 (PS), 阻抗 $10^{6-9} \Omega$   
 上带: 聚乙烯 (PET), 阻抗 $10^{6-11} \Omega$   
 卷盘: 聚苯乙烯。

纸箱规格: 345\*345\*23MM  
 纸箱规格: 345\*345\*35MM

THIS DOCUMENT IS THE SOLE PROPERTY OF BBJconn Technology Co.,Ltd. Corporation AND SHOULD NOT BE USED IN WHOLE OR IN PART WITHOUT PRIOR WRITTEN PERMISSION.		深圳市步步精科技有限公司	
PDWG.NO: 0469-2		APPD. JM_Zheng CHKD. LYX DR. LHC	NAME:TYPE-C 24P 母座 直立式 四脚插 带柱 H=10.50 端子SMT 外壳脚长2.65 (C-TF419-LH47XXY) PJ. NO.: 126-224-240001-J6G SIZE: A4   DRW NO.: FINISH: SEE NOTES   MAT'L.: SEE NOTES SCALE: N/A   REV.: A0   UNIT: mm   PAGE: 2/2