

REV.	ECN NO.	CONTENT	DATE	ENGINEER
A0		Initial release	/	SGF

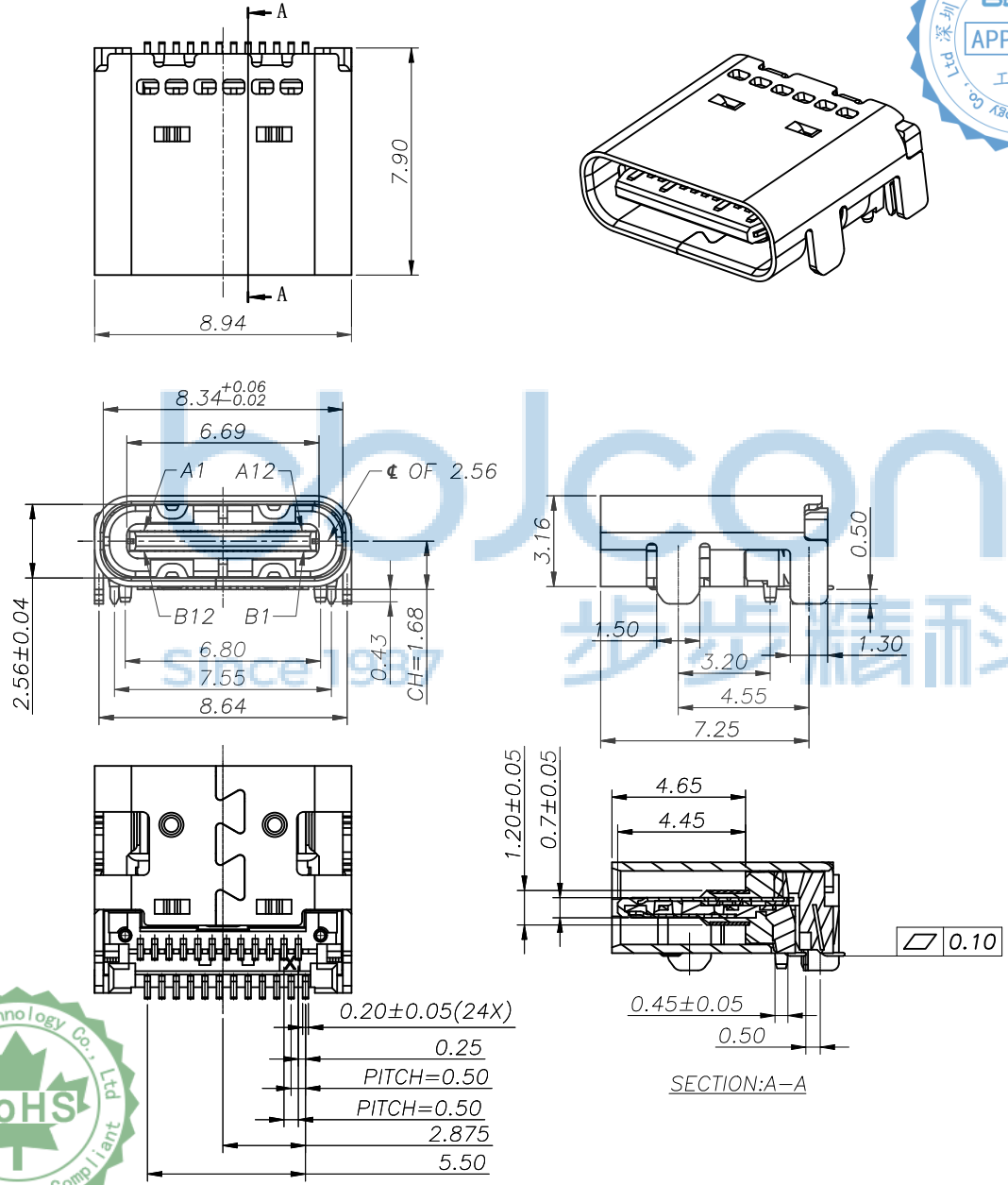

NOTE:

- MATERIAL SPECIFICATION:
 - HOUSING: HIGH TEMPERATURE RESISTANT PLASTIC, PA9T UL94 V-0.
 - CONTACTS: COPPER ALLOY C18150
 - MID PLATE: STAINLESS STEEL SUS301
 - FRONT SHELL: STAINLESS STEEL SUS304
 - EMI PLATE: STAINLESS STEEL SUS304
- PLATING SPECIFICATION:
 - CONTACTS:
 - Ni 50u" MIN. UNDER PLATED OVER ALL.
 - Au PLATED ON THE FUNCTIONAL AREA OF CONTACT.
 - (GOLD PLATING THICKNESS FOLLOW THE P/N)
 - PLATING SPECIFICATIONS OF THE SOLDER AREA FOLLOW THE P/N
 - FRONT SHELL:
 - Ni 30u" MIN. UNDER PLATED OVER ALL.
 - MID PLATE:
 - Ni 30u" MIN. UNDER PLATED OVER ALL.
 - Sn 80u" MIN. PLATED OVER ALL
 - EMI PLATE:
 - CLEAR ONLY
- MECHANICAL PERFORMANCE,
 - INSERTION FORCE: 0.5~2.0kgf.
 - REMOVAL FORCE: 0.8kgf~2.0kgf.
 - DURABILITY: 10000 CYCLES.
- ELECTRICAL PERFORMANCE,
 - CURRENT RATING: 5.0A
VOLTAGE RATING: 5.0V
 - LLCR:
 - VBUS & GND PINS AND OTHER PINS: 40mA/PIN MAX.
 - LLCR MAX. CHANGE OF ALL PINS: 10mA.
 - INSULATION RESISTANCE: 100M Ω MIN
 - DIELECTRIC WITHSTAND VOLTAGE, AC 100V FOR 1 MINUTE.
- ENVIRONMENTAL PERFORMANCE:
 - OPERATING TEMPERATURE: -25°C~+85°C.
- IR REFLOW:
 - THE PEAK TEMPERATURE ON THE BOARD SHALL BE MAINTAINED FOR 10 SECONDS AT 260°C.
- Salt spray: 48 hour



THIS DOCUMENT IS THE SOLE PROPERTY OF BBJconn Technology Co., Ltd. Corporation AND SHOULD NOT BE USED IN WHOLE OR IN PART WITHOUT PRIOR WRITTEN PERMISSION. PDWG.NO: 0049-1	深圳市步步精科技有限公司		NAME: TYPE-C 24P 母座 双排SMT 四脚插 带柱 带凸点 L=7.90 CH=1.68 镀金3u 编带		
	.X: ±0.38 .XX: ±0.25 .XXX: ±0.13	X': ±3' .X': ±2' .XX': ±1'	APPD. JM_Zheng	PJ. NO.: 126-221-240003-M8G	
	OR IN PART WITHOUT PRIOR WRITTEN PERMISSION.	CHKD. LYX		SIZE: A4 DRW NO.:	
	DR. SGF	FINISH: SEE NOTES		MAT'L.: SEE NOTES	
SCALE: N/A		REV.: A0	UNIT: mm	PAGE: 1/3	

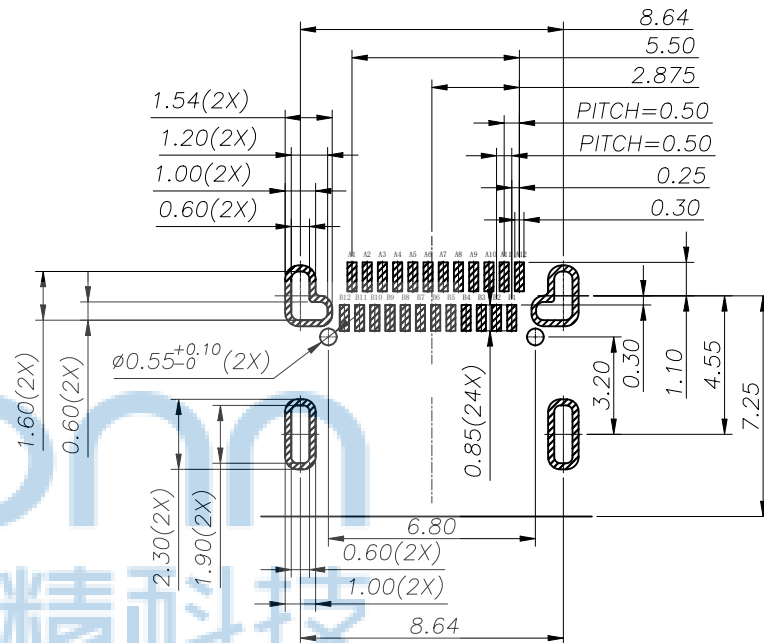
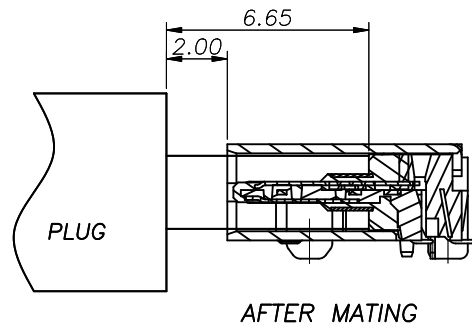

USB TYPE-C PIN ASSIGNMENTS

PIN NUMBER	SIGNAL NAME	PIN NUMBER	SIGNAL NAME
A1	GND	B12	GND
A2	TXp1	B11	RXp1
A3	TXn1	B10	RXn1
A4	VBUS	B9	VBUS
A5	CC1	B8	SBU2
A6	Dp1	B7	Dn2
A7	Dn1	B6	Dp2
A8	SBU1	B5	CC2
A9	VBUS	B4	VBUS
A10	RXn2	B3	TXn2
A11	RXp2	B2	TXp2
A12	GND	B1	GND

RECOMMENDED PCB LAYOUT(TOP VIEW)
THICKNESS 0.60MM;DEFAULT TOLERANCE:±0.05



THIS DOCUMENT IS THE SOLE PROPERTY OF BBJconn Technology Co.,Ltd. Corporation AND SHOULD NOT BE USED IN WHOLE OR IN PART WITHOUT PRIOR WRITTEN PERMISSION.		深圳市步步精科技有限公司	
PDWG.NO: 0049-1	APPD. JM_Zheng	NAME: TYPE-C 24P 母座 双排SMT 四脚插 带柱 带凸点 L=7.90 CH=1.68 镀金3u 编带	
	CHKD. LYX	PJ. NO.: 126-221-240003-M8G	
	DR. SGF	SIZE: A4 DRW NO.:	
		FINISH: SEE NOTES	MAT'L.: SEE NOTES
		SCALE: N/A	REV.: A0 UNIT: mm PAGE: 2/3

REV.	ECN NO.	CONTENT	DATE	ENGINEER
A0		Initial release	/	SGF

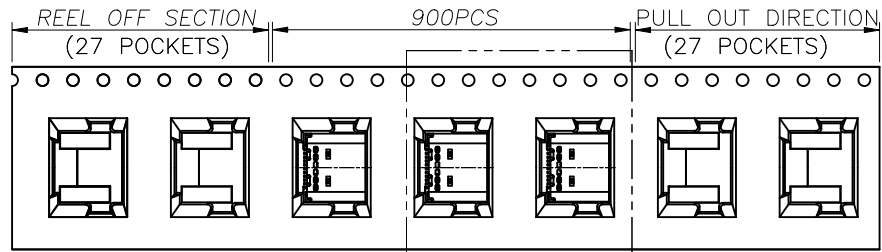

SEE DETAIL X

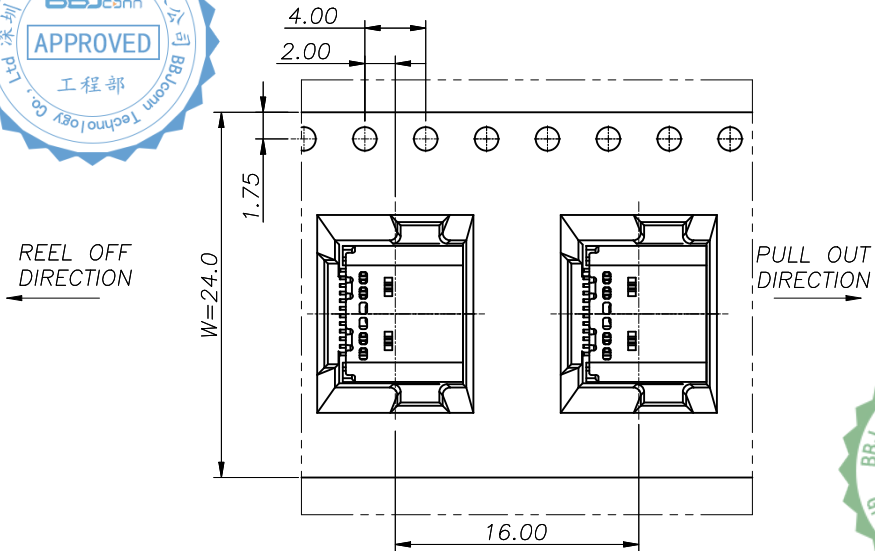
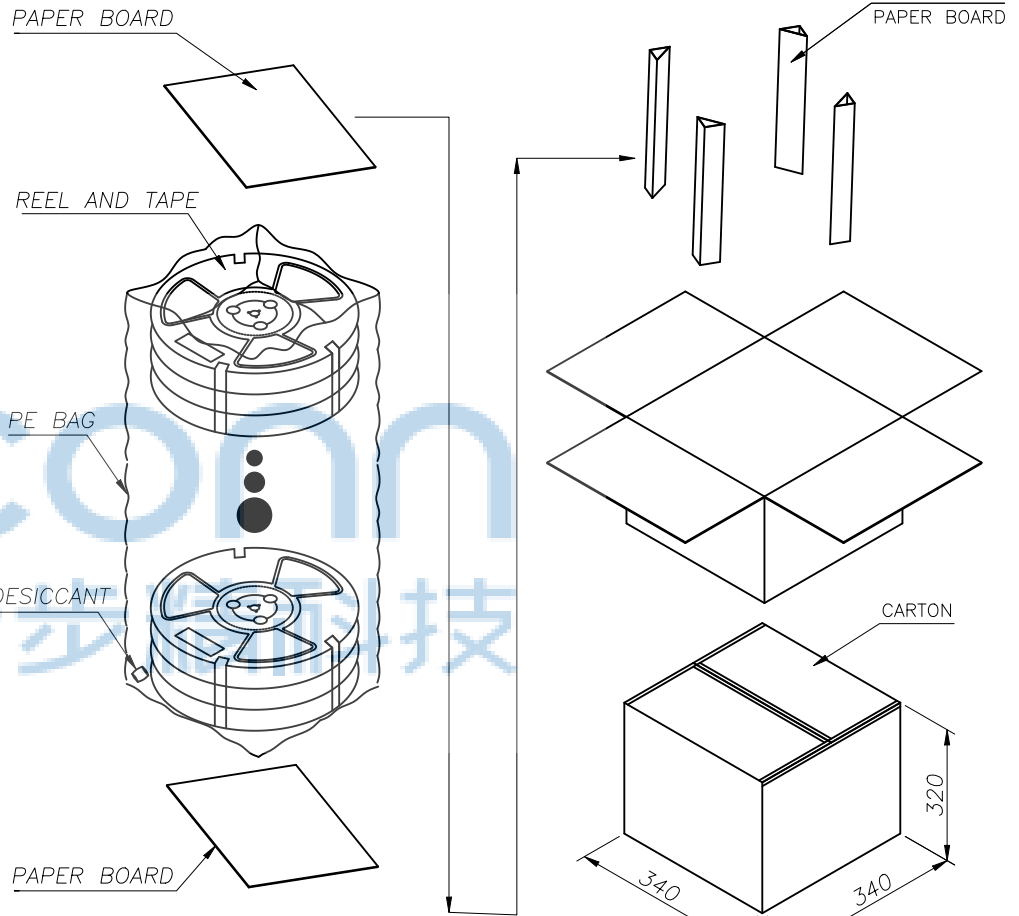
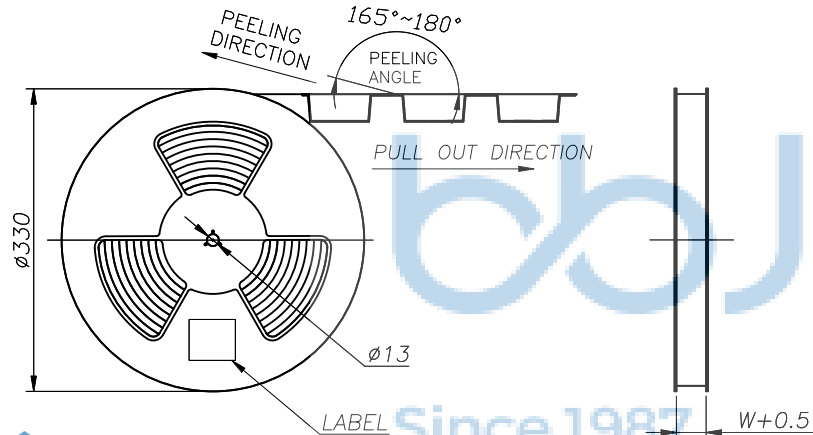

	REEL	CARTON
CONNECTOR (PCS)	900	9000

THIS DOCUMENT IS THE SOLE PROPERTY OF BBJconn Technology Co., Ltd. Corporation AND SHOULD NOT BE USED IN WHOLE OR IN PART WITHOUT PRIOR WRITTEN PERMISSION.
PDWG.NO: 0049-1

深圳市步步精科技有限公司		NAME: TYPE-C 24P 母座 双排SMT 四脚插 带柱 带凸点 L=7.90 CH=1.68 镀金3u 编带	
		PJ. NO.: 126-221-240003-M8G	
APPD. JM_Zheng	SIZE: A4		DRW NO.:
CHKD. LYX	FINISH: SEE NOTES		MAT'L.: SEE NOTES
DR. SGF	SCALE: N/A	REV.: A0	UNIT: mm

E