

REV.	DESCRIPTION	NAME	DATE
A	NEWS ISSUE		

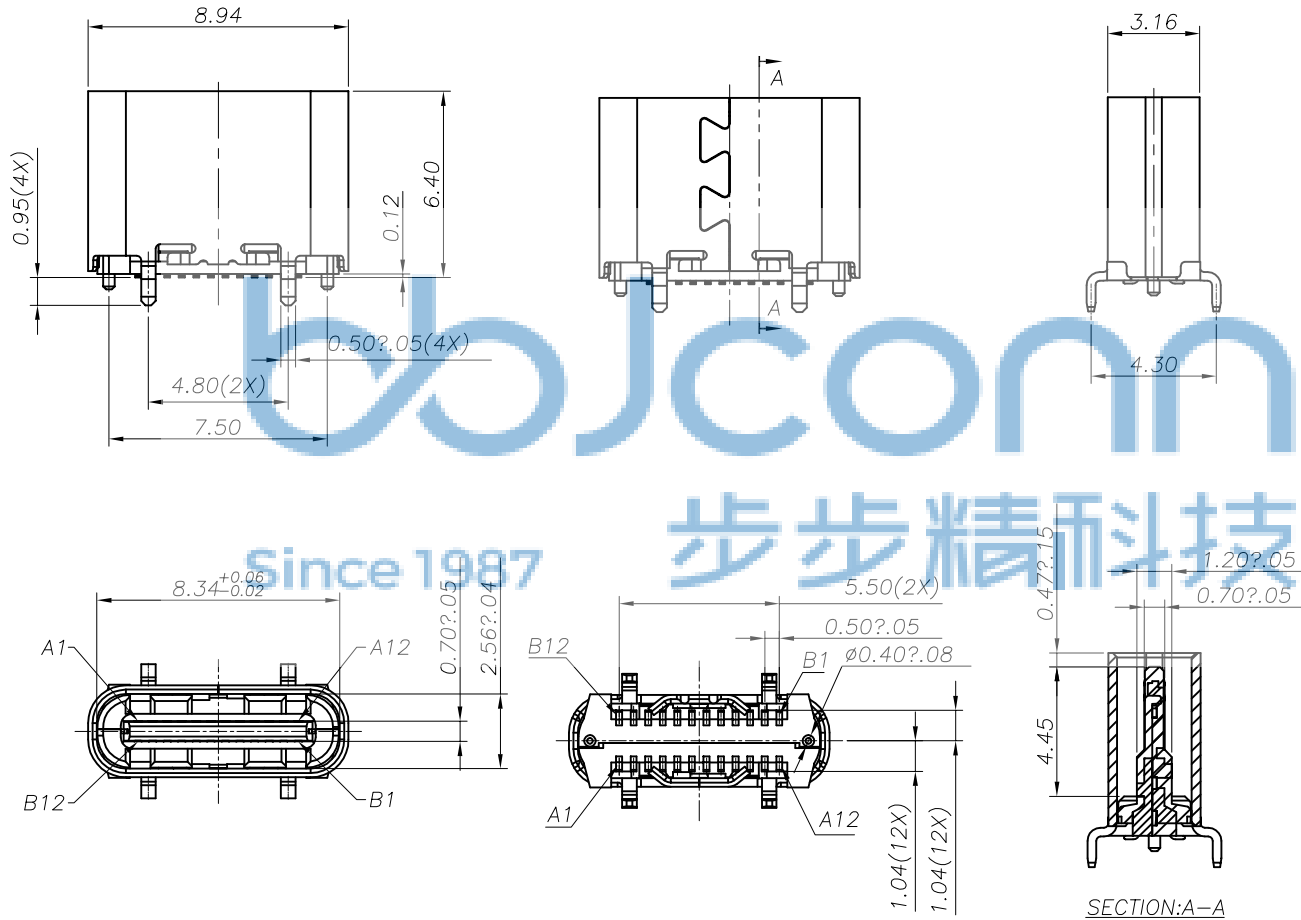

NOTE:

1. MATERIAL SPECIFICATION:

1. HOUSING: HIGH TEMPERATURE RESISTANT PLASTIC, UL94 V-0. PA9T
2. TERMINAL: COPPER ALLOY (C1815)
3. MID PLATE: STAINLESS STEEL (SUS301)
4. FRONT SHELL: STAINLESS STEEL (SUS304)

2. PLATING SPECIFICATION:

2-1. TERMINAL:

- Ni 50u" MIN. UNDER PLATED OVER ALL.
- Au PLATED ON THE FUNCTIONAL AREA OF CONTACT.
- (GOLD PLATING THICKNESS FOLLOW THE P/N)

PLATING SPECIFICATIONS OF THE SOLDER AREA FOLLOW THE P/N

2-2. FRONT SHELL:

- Ni 50u" MIN. UNDER PLATED OVER ALL.

2-3. MID PLATE:

- CLEAR ONLY

3. MECHANICAL PERFORMANCE,

- 3-1. INSERTION FORCE: 0.5~2.0kgf.
- 3-2. REMOVAL FORCE: 0.8kgf~2.0kgf.
- 3-3. DURABILITY: 10000 CYCLES.

4. ELECTRICAL PERFORMANCE,

- 4-1. VOLTAGE RATING: 5 V DC/AC (RMS. max)
CURRENT RATING: 5 AMPS. FOR TOTAL VBUS/GND PINS;
1.25AMPS FOR CC PIN, 0.25 AMPS. FOR ALL OTHER CONTACT.
- 4-2. LLCR:
VBUS & GND PINS AND OTHER PINS: 40mΩ /PIN MAX.
LLCR MAX. CHANGE OF ALL PINS: 10mΩ.
- 4-3. INSULATION RESISTANCE: 100MΩ MIN
- 4-4. DIELECTRIC WITHSTAND VOLTAGE, AC 100V FOR 1 MINUTE.

5. ENVIRONMENTAL PERFORMANCE:

- OPERATING TEMPERATURE: -25° C~+85° C.

6. IR REFLOW:

- THE PEAK TEMPERATURE ON THE BOARD SHALL BE MAINTAINED FOR 10 SECONDS AT 260° C.

SECTION:A-A

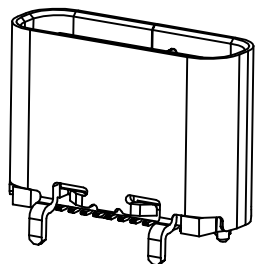

TOLERANCE UNSPECIFIED	
.0	±0.35
.00	±0.25
.000	±0.15
X.°	±2.00°
CUSTOMER DRAWING	

深圳市步步精科技有限公司

TITLE: TYPE-C 24P 母座 直立式 H=6.4 四脚插 带柱
端子SMT PA9T黑胶 镀金1u 锡脚G-F (GAP-ACF014-6R)

DRAWN/ DATE	设计 LHC	SIZE:A4	UNIT:MM	PART. NO:	
CHECKED/ DATE	LYX	SCALE: 1:1	PROJECTION	REV.: 版本	
APPROVED/ DATE	LJP	DWG. PATH	0049-1	SHEET: 页码	

REV.	DESCRIPTION	NAME	DATE
A	NEWS ISSUE		

USB TYPE-C PIN ASSIGNMENTS

PIN NUMBER	SIGNAL NAME	PIN NUMBER	SIGNAL NAME
A1	GND	B12	GND
A2	SSTXp1	B11	SSRXp1
A3	SSTXn1	B10	SSRXn1
A4	Vbus	B9	Vbus
A5	CC1	B8	SBU2
A6	Dp1	B7	Dn2
A7	Dn1	B6	Dp2
A8	SBU1	B5	CC2
A9	VBUS	B4	Vbus
A10	SSRXn2	B3	SSTXn2
A11	SSRXp2	B2	SSTXp2
A12	GND	B1	GND

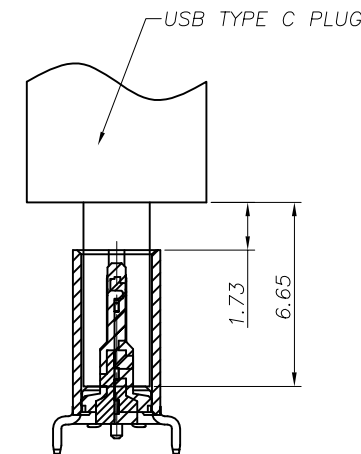
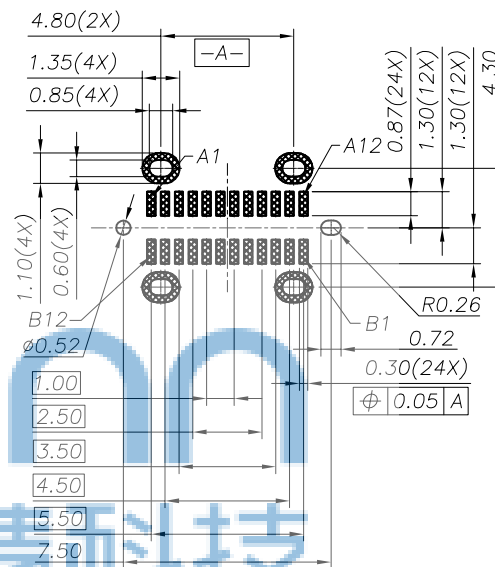

FEMALE AND MALE MATCHING DRAWING

RECOMMENDED PCB LAYOUT(TOP VIEW)
THICKNESS 0.8±.10MM;DEFAULT TOLERANCE:±.05

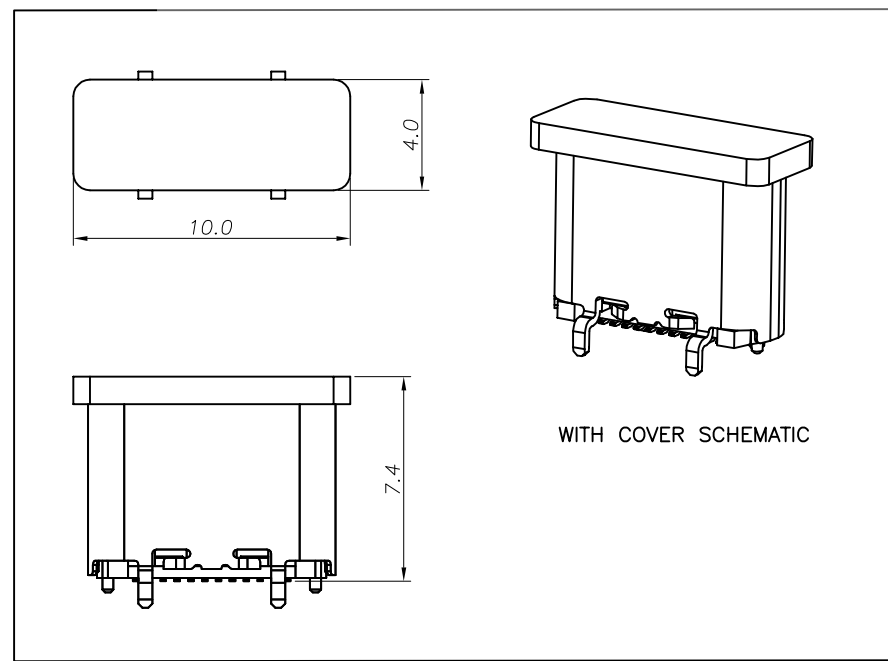

WITH COVER SCHEMATIC



TOLERANCE UNSPECIFIED .0 ±0.35 .00 ±0.25 .000 ±0.15 X ° ±2.00° CUSTOMER DRAWING		深圳市步步精科技有限公司		
DRAWN/ DATE: 设计 LHC		SIZE: A4	UNIT: MM	PART. NO:
CHECKED/ DATE: LYX		SCALE: 1:1	PROJECTION	REV.: 版本
APPROVED/ DATE: LJP		DWG. PATH	0049-1	SHEET: 页码

REV.	DESCRIPTION	NAME	DATE
A	NEWS ISSUE		

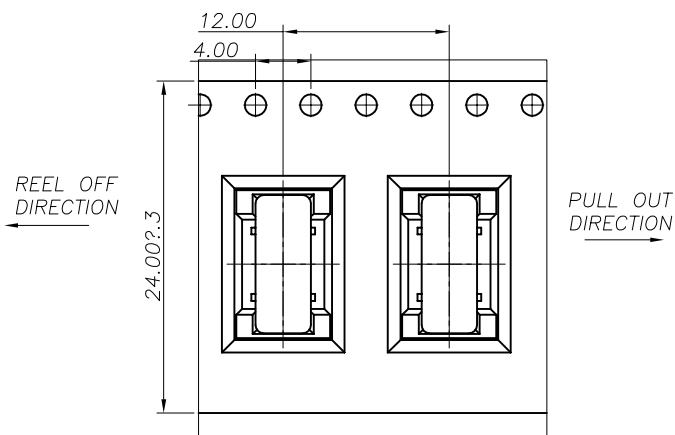
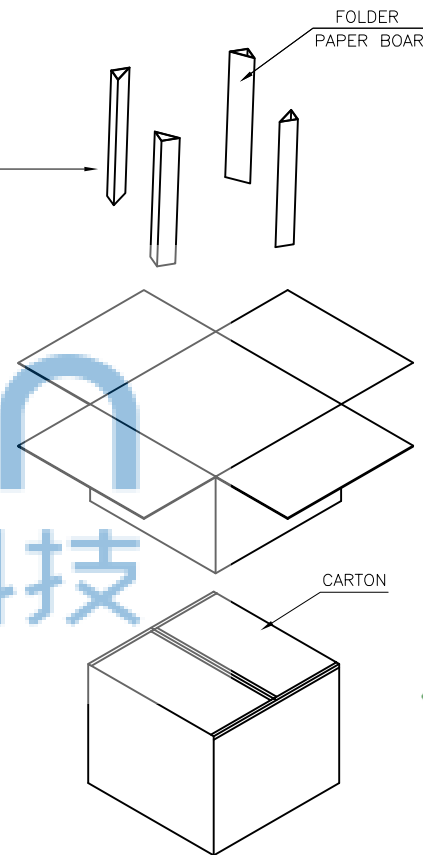
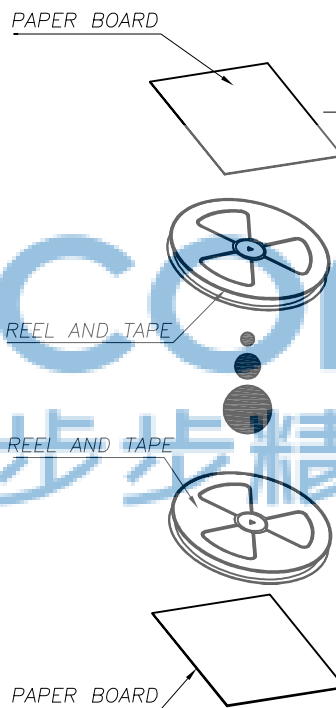
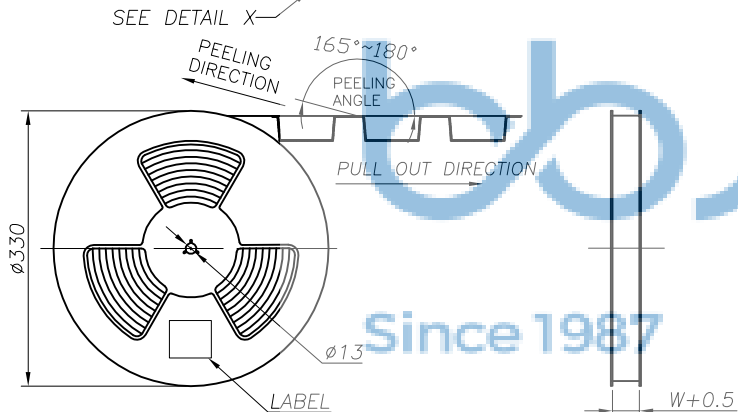
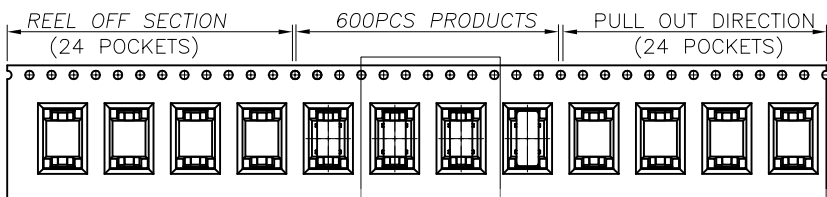

	REEL/TRAY	CARTON
CONNECTOR (PCS)	600	6000

<p>TOLERANCE UNSPECIFIED</p> <p>.0 ±0.35</p> <p>.00 ±0.25</p> <p>.000 ±0.15</p> <p>X.° ±2.00°</p> <p>CUSTOMER DRAWING</p>		<p>深圳市步步精科技有限公司</p> <p>TITLE: TYPE-C 24P 母座 直立式 H=6.4 四脚插 带柱 端子SMT PA9T黑胶 镀金1u 锡脚G-F (GAP-ACF014-6R)</p>	
DRAWN/ DATE	设计 LHC	SIZE:A4	UNIT:MM. PART. NO:
CHECKED/ DATE	LYX	SCALE: 1:1	PROJECTION REV.: 版本
APPROVED/ DATE	LJP	DWG. PATH	0049-1 SHEET: 页码