

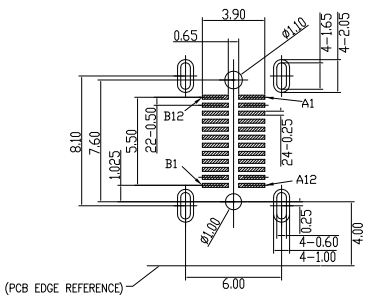

REV.	DESCRIPTION	NAME	DATE
A	NEWS ISSUE		

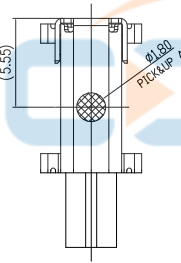

RECOMMENDED P.C.B LAYOUT
TOLERANCE ± 0.05mm (TOP VIEW)

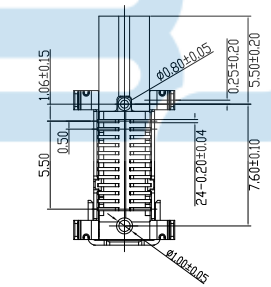
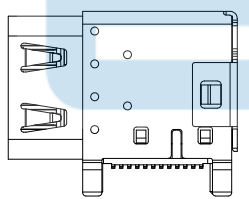
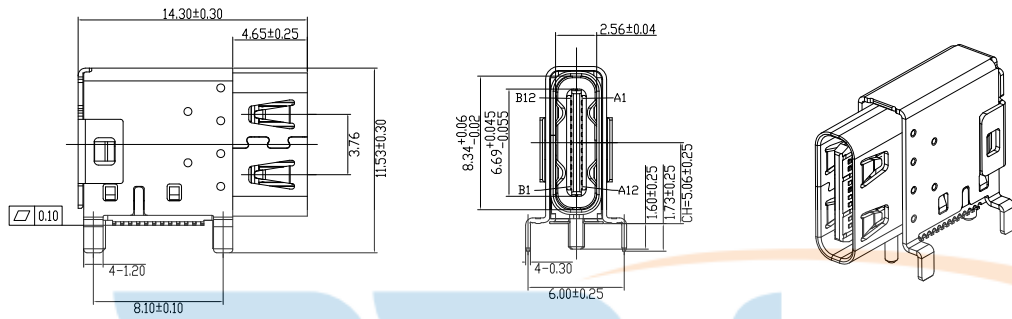
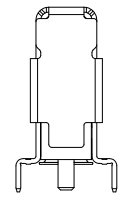
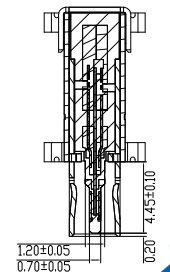

MATERIALS

1. HOUSING : LCP (UL 94V-0), BLACK.
2. TERMINAL : COPPER ALLOY, GOLD PLATED ON CONTACT AREA, GOLD FLASH PLATING ON SOLDER TAIL, NICKEL UNDERPLATED OVER ALL.
3. MID PLATE : STAINLESS STEEL.
4. SHELL : STAINLESS STEEL, NICKEL PLATING.

SPECIFICATION

1. CURRENT RATING : 5.0A FOR Vbus PIN, 1.25A FOR Vconn PIN, 0.25A FOR OTHER PINS.
2. VOLTAGE RATING : 20V DC MAX.
3. CONTACT RESISTANCE : 40mΩ.
4. INSULATION RESISTANCE : 100MΩ MIN.
5. DIELECTRIC WITHSTANDING VOLTAGE : 100 VAC MIN.
6. OPERATING TEMPERATURE : -40°C TO +85°C.
7. MATING FORCE : 5~20N.
8. UNMATING FORCE : 8~20N.
9. DURABILITY : 10,000 CYCLES.
10. RECOMMENDED PROCESS : THE PEAK TEMPERATURE ON THE BOARD SHALL MAINTAIN 260°C.



ITEM	DESCRIPTION	Q'TY	MATERIAL	FINISH	REMARK
5	TERMINAL	24	COPPER ALLOY	MATING SIDE: Au 30u*MIN; SOLDER TAIL: Gold FLASH, 50u* NICKEL OVERALL.	T=0.12
4	OUT SHELL	1	STAINLESS STEEL	NICKEL PLATING	T=0.30
3	MAIN SHELL	1	STAINLESS STEEL	NICKEL PLATING	T=0.30
2	MID PLATE	1	STAINLESS STEEL	NICKEL PLATING	T=0.15
1	MAIN HOUSING	1	HIGH TEMPERATURE		BLACK UL94V-0

BILL OF MATERIAL



公差尺寸表
Tolerance

x ±0.50 x* ±2*
x ±0.30 x* ±1*
xx ±0.10 xx* ±0.5*
xxx ±0.05

BBJconn 深圳市步步精科技有限公司

TITLE: TYPE-C 24PIN 母座L=14.3 侧插 带柱 端子SMT
CH=5.06 双外壳 带EMS弹片 编带

DRAWN/ DATE	设计 LYX	SIZE: A4	UNIT: MM.	PART. NO: UC.01.42-1W-0002
CHECKED/ DATE	审核 HMY	SCALE: 1:1	PROJECTION	REV.: 版本
APPROVED/ DATE	核准 LJP	DWG. PATH	0482-1	SHEET: 页码

USB TYPE-C PIN ASSIGNMENTS

PIN NUMBER	A1	A2	A3	A4	A5	A6	A7	A8	A9	A10	A11	A12
SIGNAL NAME	GND	SSTxp1	SSTXn1	Vbus	CC1	Dp1	Dn1	SBU1	Vbus	SSRXn2	SSRxp2	GND
PIN NUMBER	B12	B11	B10	B9	B8	B7	B6	B5	B4	B3	B2	B1
SIGNAL NAME	GND	SSRXp1	SSRXn1	Vbus	SBU2	Dn2	Dp2	CC2	Vbus	SSTXn2	SSTxp2	GND



PULL OUT DIRECTION

COVER TAPE

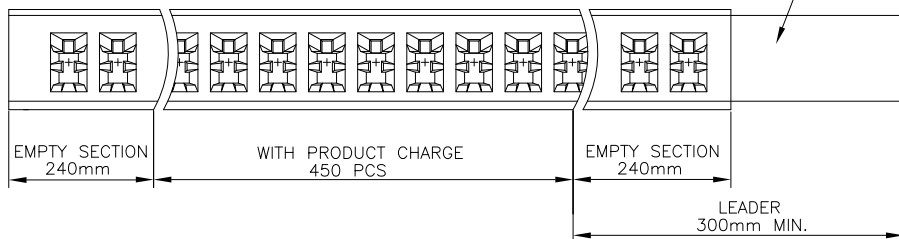

REV.	DESCRIPTION	NAME	DATE
A	NEWS ISSUE		



REELX8

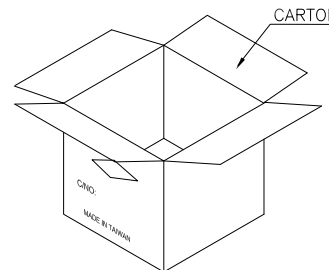
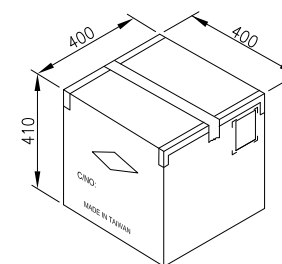
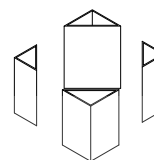
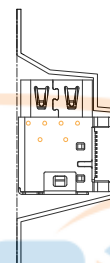
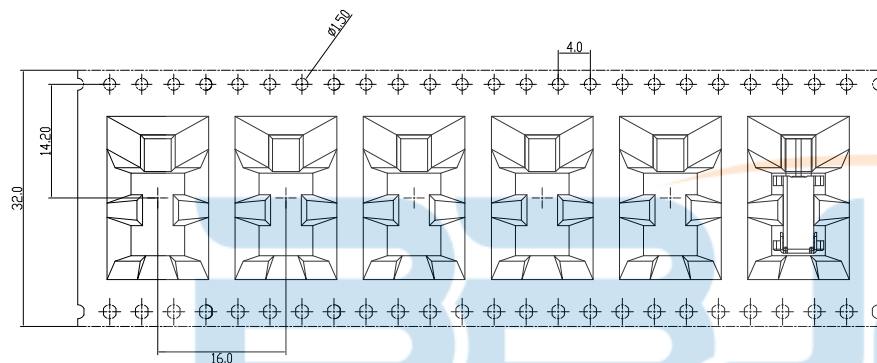
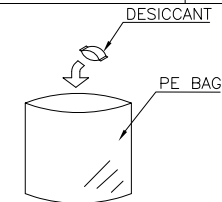

CARTON

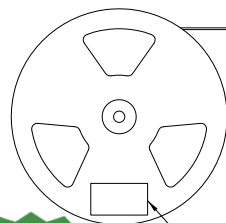
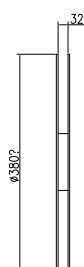

LABEL

PULL OUT DIRECTION



PACKAGE

- SIZE :
REEL : $\phi 380 \times 32$ mm
CARTON : $400 \times 400 \times 410$ mm (LxWxH)
- QUANTITY :
450 PCS / REEL
8 REEL / CARTON = 3,600 PCS

公差尺寸表
Tolerance

x	± 0.50	x'	$\pm 2'$
X	± 0.30	X'	$\pm 1'$
XX	± 0.10	XX'	$\pm 0.5'$
XXX	± 0.05		

BBJconn 深圳市步步精科技有限公司

TITLE: TYPE-C 24PIN 母座L=14.3 侧插 带柱 端子SMT
CH=5.06 双外壳 带EMS弹片 编带

DRAWN/ DATE	设计 LYX	SIZE:A4	UNIT:MM.	PART. NO: UC.01.42-1W-0002	
CHECKED/ DATE	审核 HMY	SCALE: 1:1	PROJECTION		REV.: 版本
APPROVED/ DATE	核准 LJP	DWG. PATH	0482-1		SHEET: 页码