

RECOMMENDED P.C.B. LAYOUT
TOLERANCE UNSPECIFIED ±0.05mm

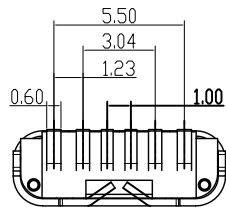

REV.	DESCRIPTION	NAME	DATE
A	NEWS ISSUE		

- Material:
 - InsertMolding:LCP UL 94V-0 Black
 - Contact:Copper Alloy, T=0.20mm
 - Shell:Stainless Steel, T=0.30mm
- Electrical:
 - Rated Voltage:30V AC/DC Maximum
 - Current Rating:3A For Vbus
1.25A For GND Pin, 0.25A For Other.
 - Insulation Resistance:100MΩ Min
 - Contact Resistance:50mΩ Max
- Mechanical:
 - Insert Force:5~20N;
 - Extract Force:Initial 8~20N,
After 10000 Cycles 6~20N;
 - Durability:8000 Cycles
- Plating
 - Terminal:Contact Area:G/F Gold Plate
Over 50u" Ni Min.Solder Area:100u"
Pure Tin Plate Over 50u" Ni Min.
 - Shell Ni:50u"Min.
- Ambient Temperature:-55° C To +85° C

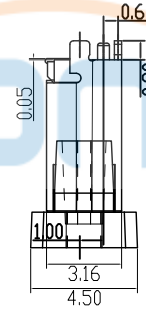
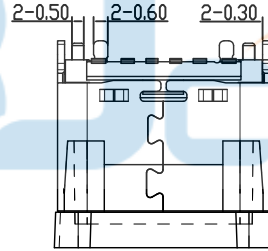
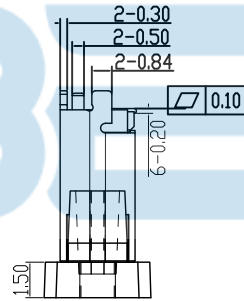
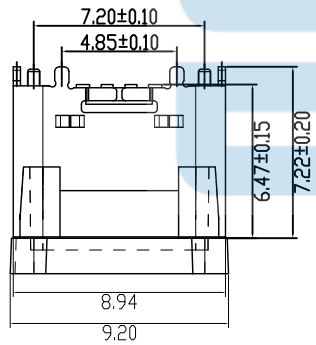

NO.	DESCRIPTION	MATERIAL	REMARKS	QTY
3	SHELL	STAINLESS STEEL	Ni/Cu Plated	1PCS
2	CONTACT	BRASS	Au Plated	1SET
1	MD	HIGH TEMPERATURE PLASTIC	BLACK	1PCS

USB TYPE-C PIN ASSIGNMENTS

PIN NUMBER	A1	A2	A3	A4	A5	A6	A7	A8	A9	A10	A11	A12
SIGNAL NAME					CC1				Vbus			GND
PIN NUMBER	B12	B11	B10	B9	B8	B7	B6	B5	B4	B3	B2	B1
SIGNAL NAME	GND			Vbus				CC2				

TOLERANCE UNSPECIFIED
.0 ±0.35
.00 ±0.25
.000 ±0.15
X.° ±2.00°
CUSTOMER DRAWING

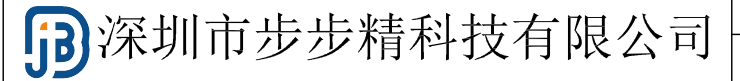

TITLE:
TYPE-C 6P 母座 直立式 H=6.47 四脚插 带定位柱 端子SMT

DRAWN/ DATE	设计 TSP	SIZE:A4	UNIT:MM.	PART. NO: UC.01.63-1W-0013
CHECKED/ DATE	审核 LYX	SCALE: 1:1	PROJECTION	REV.: 版本
APPROVED/ DATE	核准 LJP	DWG. PATH	0482-1	SHEET: 页码



REV.	DESCRIPTION	NAME	DATE
A	NEWS ISSUE		

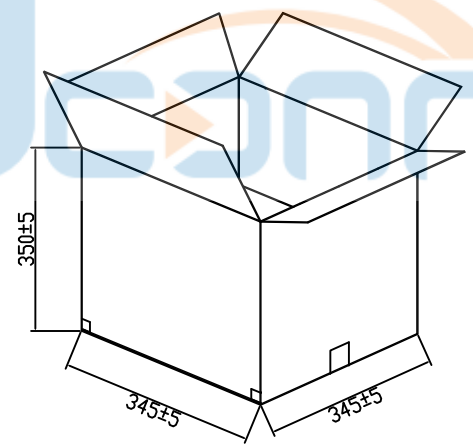
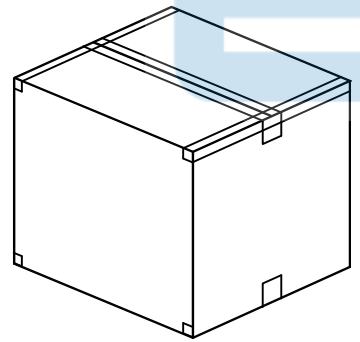
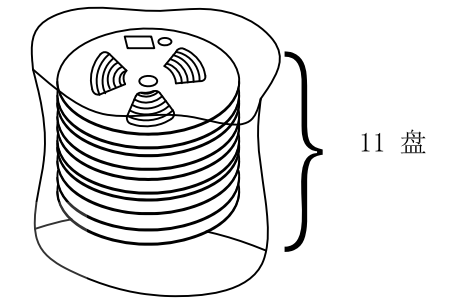
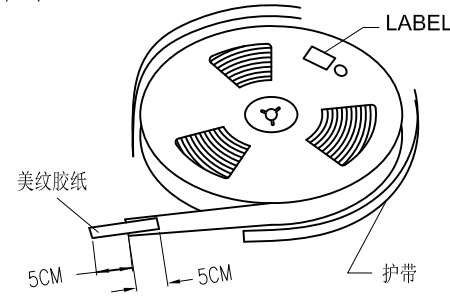
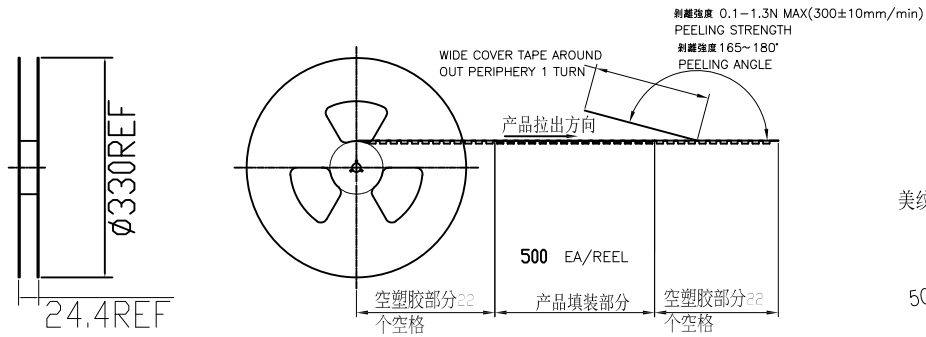

- 说明:
- 1, 将检查合格的产品, 放入承载带中, 一盘包装500PCS;
 - 2, 将11盘承载带放入纸箱中;
 - 3, 将纸箱封装好, 贴上标签.

每箱数量	净重(Kg)	毛重(Kg)
5500PCS	XXX	XXX



TOLERANCE UNSPECIFIED		深圳市步步精科技有限公司 TITLE: TYPE-C 6P 母座 直立式 H=6.47 四脚插 带定位柱 端子SMT			
.0	±0.35	SIZE:A4	UNIT:MM.	PART. NO: UC.01.63-1W-0013	
.00	±0.25	CHECKED/ DATE	设计 TSP	SCALE: 1:1	PROJECTION
.000	±0.15	APPROVED/ DATE	审核 LYX	DWG. PATH	REV.: 版本
X.°	±2.00°		核准 LJP		SHEET: 页码
CUSTOMER DRAWING				0482-1	