

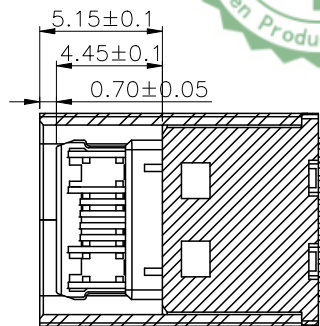

REV	ECN NO	CONTENT	DATE	ENGINEER
A0		INITIAL RELEASE	/	SGF

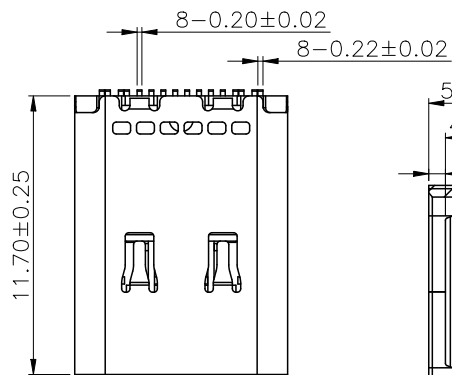

截面B-B

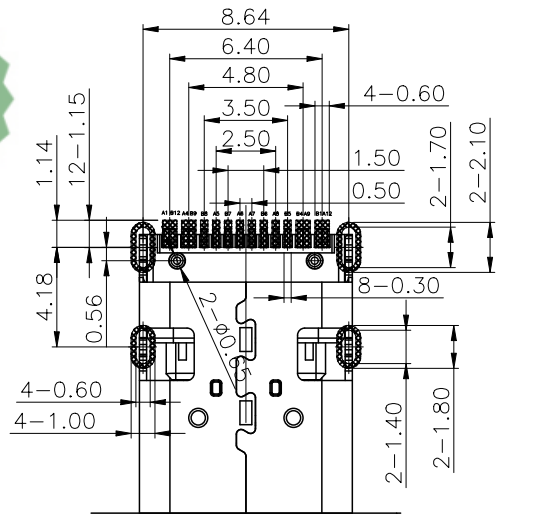

RECOMMEND P.C.B LAYOUT (CONNECTOR SIDE)  
TOLERANCE FOR PCB LAYOUT IS ± 0.05

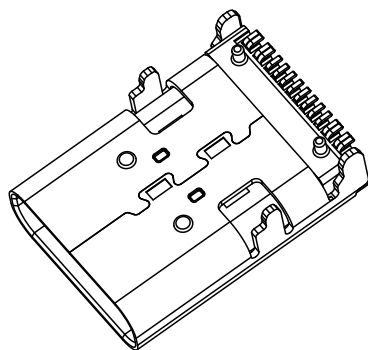
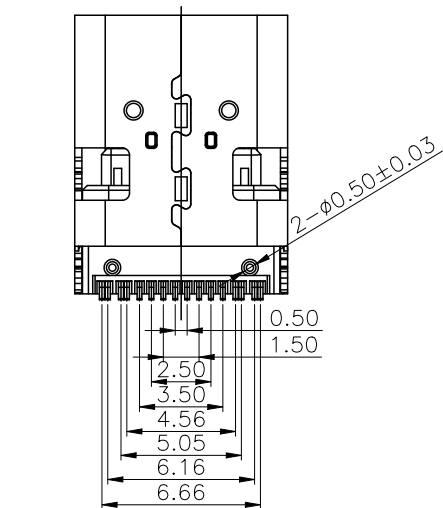
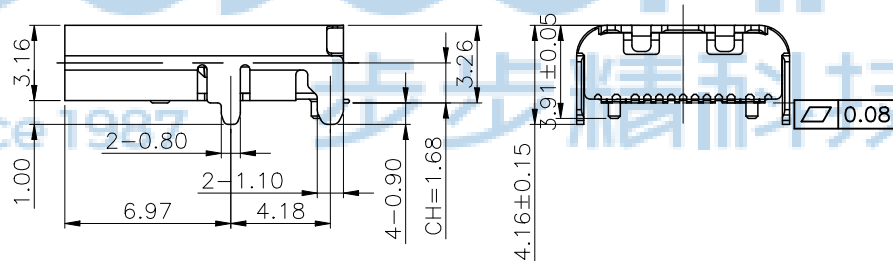
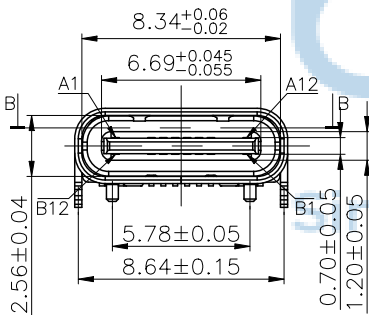

特性:

- 一、电气性能: ELECTRICAL
  1. 额定电流: 5.0A
  2. 接触阻抗: 40 MILLIOHMS MAX
  3. 耐电压: 100V AC / 1 mA MAX
  4. 绝缘阻抗: 150V DC/100 MEGA OHMS MIN
- 二、机械性能: MECHANICAL
  1. 插入力: 5~20N
  2. 拔出力: 8~20N
  3. 使用寿命: 10000次、拔出力 5N MIN
- 三、材料: MATERIAL
  1. 外壳: 不锈钢 SUS 304 T=0.30mm
  2. 胶芯: LCP UL94 V-0
  3. 端子: C7025 T=0.15
  4. 卡勾: 不锈钢 SUS 301 T=0.15mm
- 四、电镀: FINISH
  1. 端子: 接触点镀金1U"MIN  
PIN脚焊接区域镀锡80U"MIN
  2. 外壳: 镀镍50U"MIN (盐雾48H)
- 五、电镀品需做粘锡测试: 粘锡面积达到95%以上。
- 六、SMT回流焊 (峰值260° C±5° C) 不能起泡、熔胶、变色不良 (变形在公差范围以内)
- 七、工作温度: -40° C~+85° C
- 八、盐雾测试: 通过48H在浓度为5±1%盐水的盐雾测试无生锈现象。



USB TYPE-C PIN ASSIGNMENTS

PIN NUMBER	A1	A2	A3	A4	A5	A6	A7	A8	A9	A10	A11	A12
SIGNAL NAME	GND	/	/	Vbus	CC1	Dp1	Dn1	SBU1	Vbus	/	/	GND
PIN NUMBER	B12	B11	B10	B9	B8	B7	B6	B5	B4	B3	B2	B1
SIGNAL NAME	GND	/	/	Vbus	SBU2	Dn2	Dp2	CC2	Vbus	/	/	GND

THIS DOCUMENT IS THE  
SOLE PROPERTY OF  
BBJconn Technology Co.,Ltd.  
Corporation AND SHOULD  
NOT BE USED IN WHOLE  
PRIOR WRITTEN PERMISSION.  
PDWG NO: 0482-1

**深圳市步步精科技有限公司**

NAME: TYPE-C 16P 母座 SMT 板上四脚插 脚距4.18 外壳带弹 带中夹片 带柱 L=11.70 CH=1.68 编带

APPD: JM\_Zheng      PJ NO: 126-221-160010-H8G

CHKD: LYX      SIZE:A4      DRW NO:

FINISH:SEE NOTES      MAT'L:SEE NOTES

DR: SGF      SCALE:N/A      REV:A0      UNIT:mm      PAGE:1/2

REV	ECN NO	CONTENT	DATE	ENGINEER
AO		INITIAL RELEASE	/	SGF

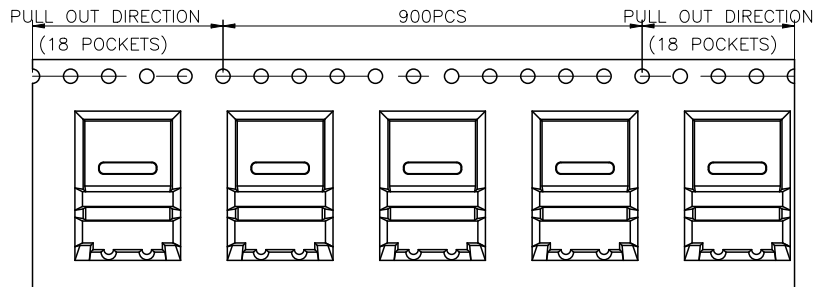

① 产品入载带示意图



内标签

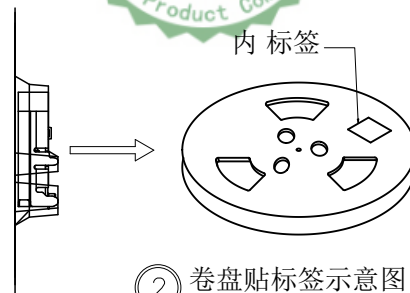

② 卷盘贴标签示意图

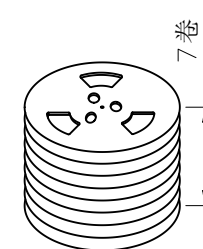

③ 7盘产品叠层示意图

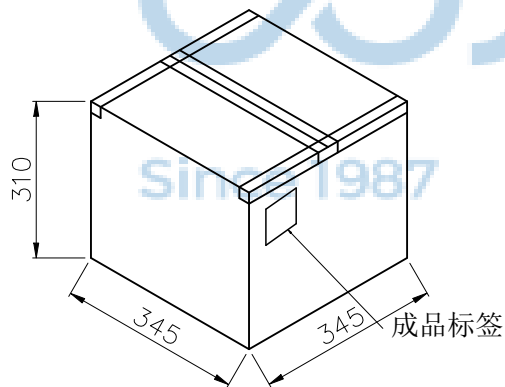

⑤ 外箱封箱示意图

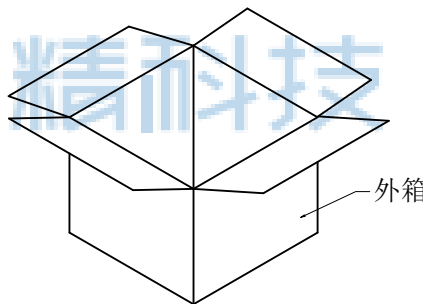

④ 产品入外箱示意图



包装说明:

1. 将检验好的成品;对插口朝前放入载带;每卷装900PCS产品;具体如图一所示
2. 将包装好的产品;每盘必需贴上内标签;具体如图二所示
3. 将贴好内标签的产品每7盘叠;具体如图三所示
5. 装好后并封好纸箱及贴好相关标签;具体如图五所示;  
(产品包装的标签,如客户有要求,请按客户要求包装出货)
6. 载带前面留18PCS空格,后面留18PCS空格
7. COVER与CARRY剥离力:50-125g,速度:300mm/分钟左右,剥离角度:165°-180°

	REEL	CARTON
CONNECTOR (PCS)	900	6300

THIS DOCUMENT IS THE  
SOLE PROPERTY OF  
BBJconn Technology Co.,Ltd.  
Corporation AND SHOULD  
NOT BE USED IN WHOLE  
PRIOR WRITTEN PERMISSION.  
PDWNG NO: 0482-1

**深圳市步步精科技有限公司**

.X: ±0.38 X': ±3'  
.XX: ±0.25 .X': ±2'  
.XXX: ±0.13 .XX': ±1'

NAME: TYPE-C 16P 母座 SMT 板上四脚插 脚距4.18 外壳带弹 带中夹片 带柱 L=11.70 CH=1.68 编带

APPD JM\_Zheng  
CHKD LYX  
DR SGF

PJ NO: 126-221-160010-H8G  
SIZE:A4 DRW NO:  
FINISH:SEE NOTES MAT'L:SEE NOTES  
SCALE:N/A REV:AO UNIT:mm PAGE:2/2