

REV.	ECN NO	CONTENT	DATE	ENGINEER
A0		Initial release	/	TSP

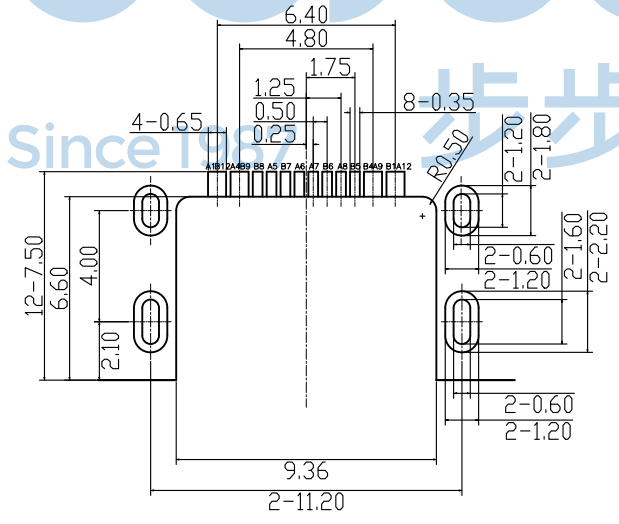

**SPECIFICATION:**

- ELECTRICAL CHARACTERISTICS:
  - CURRENT RATING: 3A
  - TEMPERATURE RANGE: -40 ° C ~ 85 ° C
  - CONTACT RESISTANCE: 30 MILLIONHM MAX.
  - DIELECTRIC WITHSTANDING VOLTAGE: 100 VAC r. m. s
  - INSULATION RESISTNACE: 100 MEGOHMS MIN.
- MECHANICAL CHARACTERISTICS
  - INSERTION FORCE: 5~20N
  - EXTRACTION FORCE: INITIALn:8~20N, ATER TEST 6~20N
  - DURABILITY:10,000 CYCLES
- THE SHELL LENTH IS LESS THAN THE MINIMUM SPECIFIED BY THE USB TYPE-C STANDARD. AS SUCH IS CONNOT INDENOENDENTLY BE GUARANTEED TO MEET ALL TYPE-C MECHANICAL REQUIREMENTS.

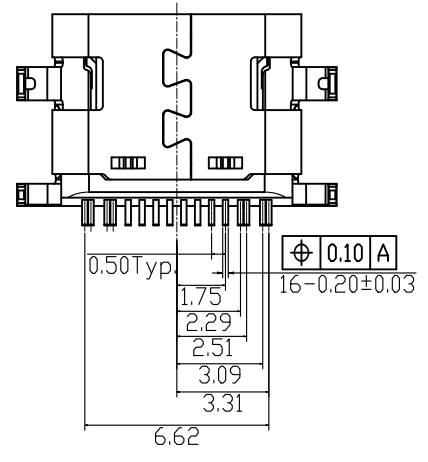
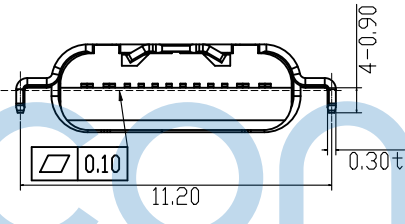
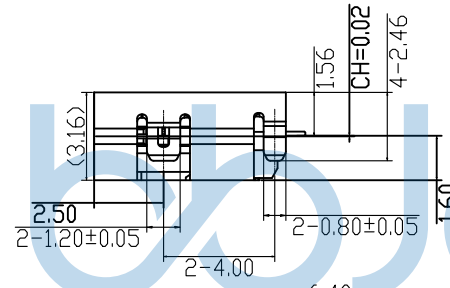
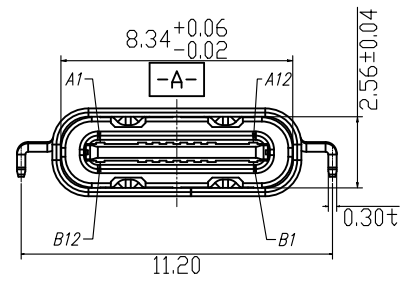
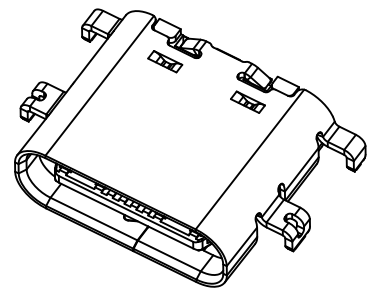
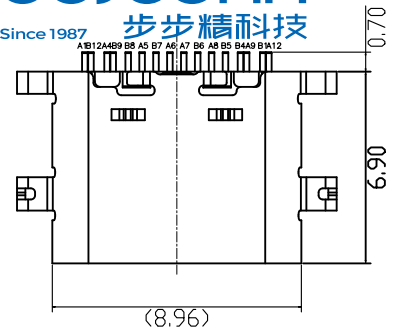

P.C.B LAYOUT VIEW TOLERANCE ±0.05



**USB TYPE-C PIN ASSIGNMENTS**

PIN NUMBER	A1	A2	A3	A4	A5	A6	A7	A8	A9	A10	A11	A12
SIGNAL NAME	GND			V <sub>BUS</sub>	CC1	Dp1	Dn1	SBU1	V <sub>BUS</sub>			GND
PIN NUMBER	B12	B11	B10	B9	B8	B7	B6	B5	B4	B3	B2	B1
SIGNAL NAME	GND			V <sub>BUS</sub>	SBU2	Dn2	Dp2	CC2	V <sub>BUS</sub>			GND

4	OUT_SHELL	1 PCS	STAINLESS STEEL	Ni Plated
3	CONTACT	1 SET	COPPER ALLOY	Au & Ni Plated
2	MOLDING HOUSING	1 PCS	PLASTIC	None
1	SHELL	1 PCS	STAINLESS STEEL	Ni Plated
NO.	DESCRIPTION	QTY.	MATERIAL	FINISHED

THIS DOCUMENT IS THE SOLE PROPERTY OF BBJconn Technology Co., Ltd. Corporation AND SHOULD NOT BE USED IN WHOLE OR IN PART WITHOUT PRIOR WRITTEN PERMISSION.

PDWG.NO: 0482-1 DR. TSP

NAME: TYPE-C 16P 母座 沉板1.6 四脚插 SMT L=6.90 CH=0.02 编带

PJ. NO.: 126-221-160013-H8G

SIZE: A4 DRW NO.:

FINISH: SEE NOTES MAT'L.: SEE NOTES

SCALE: N/A REV.: A0 UNIT: mm PAGE: 1/2

REV.	ECN NO	CONTENT	DATE	ENGINEER
A0		Initial release	/	TSP

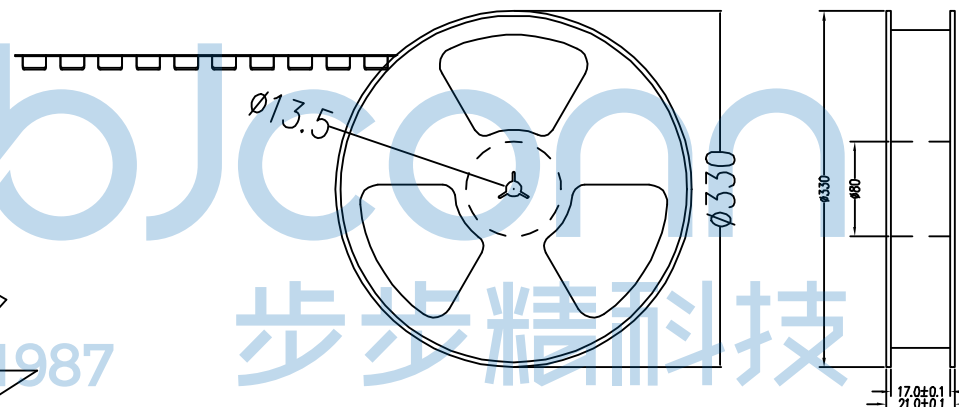
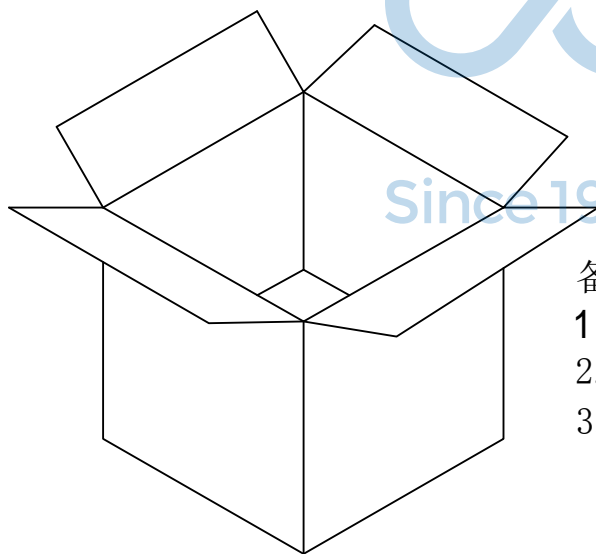
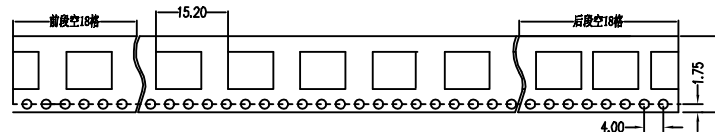
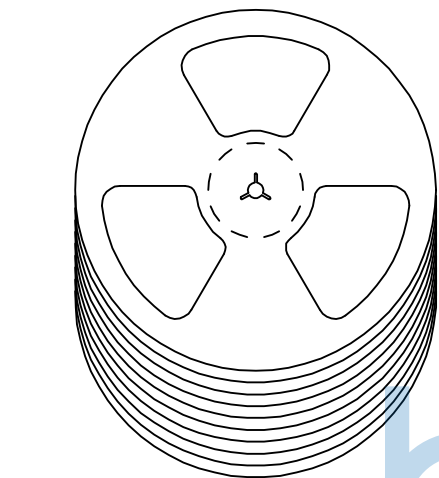

备注:

1. 包装数量：1000/PCS/卷，10卷/箱
2. 包装袋长度：每卷前后各空10-20个空格，中间包装。
3. 材质：  
载体：聚丙烯（PS），  
上带：聚乙烯（PET），  
卷盘：聚苯乙烯。

纸箱规格：345\*345\*23MM

纸箱规格：345\*345\*35MM

THIS DOCUMENT IS THE SOLE PROPERTY OF BBJconn Technology Co.,Ltd. Corporation AND SHOULD NOT BE USED IN WHOLE OR IN PART WITHOUT PRIOR WRITTEN PERMISSION.		<b>深圳市步步精科技有限公司</b>	
.X: ±0.38 .XX: ±0.25 .XXX: ±0.13		X': ±3" .X': ±2" .XX': ±1"	
APPD.	JM_Zheng	NAME: TYPE-C 16P 母座 沉板1.6 四脚插 SMT L=6.90 CH=0.02 编带	
CHKD.	LYX	PJ. NO.: 126-221-160013-H8G	
DR.	TSP	SIZE: A4   DRW NO.:	
PDWG,NO:	0482-1	FINISH: SEE NOTES   MAT'L.: SEE NOTES	
		SCALE: N/A   REV.: A0   UNIT: mm   PAGE: 2/2	