



REV.	DESCRIPTION	NAME	DATE
A	NEWS ISSUE		

SPECIFICATION:

1. ELECTRICAL CHARACTERISTICS:

- 1.1 CURRENT RATING: 5A
- 1.2 TEMPERATURE RANGE: -40 ° C ~ 85 ° C
- 1.3 CONTACT RESISTANCE: 30 MILLIONHM MAX.
- 1.4 DIELECTRIC WITHSTANDING VOLTAGE: 100 VAC r.m.s
- 1.5 INSULATION RESISTNACE: 100 MEGOHMS MIN.

2. MECHANICAL CHARACTERISTICS

- 2.1 INSERTION FORCE: 5~20N
- 2.2 EXTRACTION FORCE: Initial:8~20N, ATER TEST 6~20N
- 2.3 DURABILITY:10,000CYCLES

3. THE SHELL LENTH IS LESS THAN THE MINIMUM SPECIFIED BY THE USB TYPE C STANDARD. AS SUCH IS CONNOT INDENOENDENTLY BE GUARANTEED TO MEET ALL TYPE C MECHANICAL REQUIREMENTS.

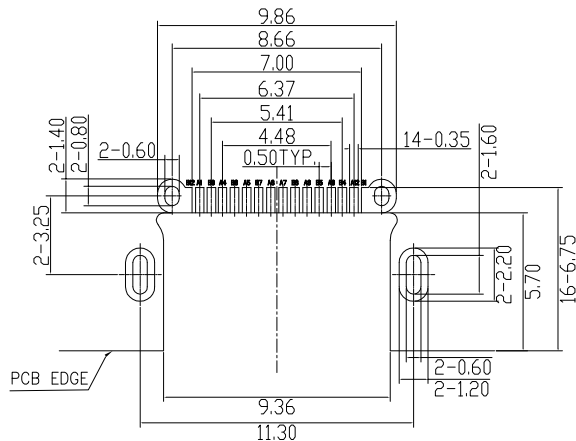
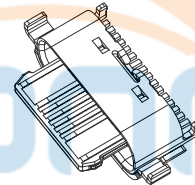
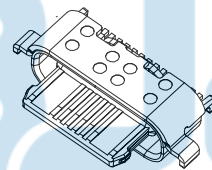
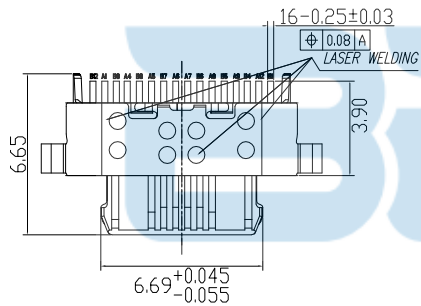
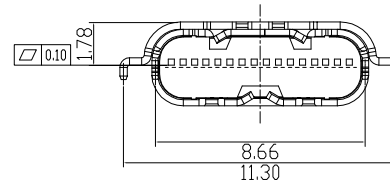
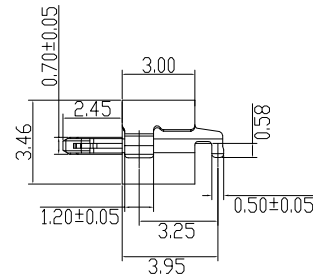
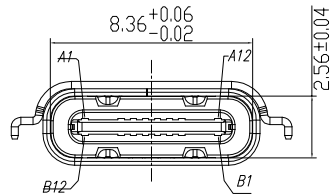

P.C.B LAYOUT VIEW TOLERANCE ±0.05

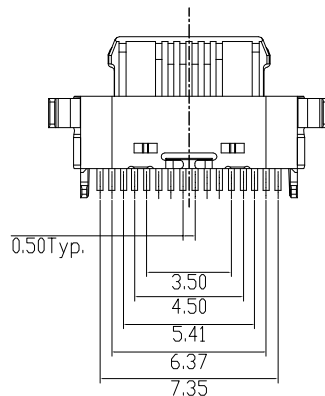

USB TYPE-C PIN ASSIGNMENTS

NO.	DESCRIPTION	QTY.	MATERIAL	FINISHED
2	IM HOUSING	1 PCS	HIGH TEM. PLASTIC+COPPER ALLOY +STAINLESS STEEL	TERMINAL Au & Ni Plated
1	SHELL+OUT SHELL	1 PCS	STAINLESS STEEL	Ni Plated

PIN NUMBER	A1	A2	A3	A4	A5	A6	A7	A8	A9	A10	A11	A12
SIGNAL NAME	GND			V _{bus}	CC1	Dp1	Dn1	SBU1	V _{bus}			GND
PIN NUMBER	B12	B11	B10	B9	B8	B7	B6	B5	B4	B3	B2	B1
SIGNAL NAME	GND			V _{bus}	SBU2	Dn2	Dp2	CC2	V _{bus}			GND

公差尺寸表
Tolerance

x.	±0.50	x.*	± 2°
.x	±0.30	.x*	± 1°
.xx	±0.15	.xx*	± 0.5°
.xxx	± 0.05		

深圳市步步精科技有限公司

TITLE:
TYPE-C 16P 母座 四脚插 沉板1.68 L=3.0 舌片外露2.45 端子SMT

DRAWN/ DATE	设计	LHC	SIZE:A4	UNIT:MM.	PART. NO:	126-221-160014-H8G	
CHECKED/ DATE	审核	LYX	SCALE: 1:1	PROJECTION			REV.: 版本
APPROVED/ DATE	核准	LJP	DWG. PATH	0482-1		SHEET: 页码	

REV.	DESCRIPTION	NAME	DATE
A	NEWS ISSUE		

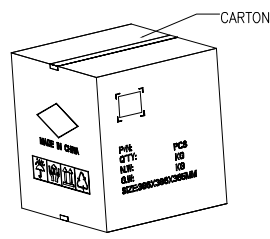
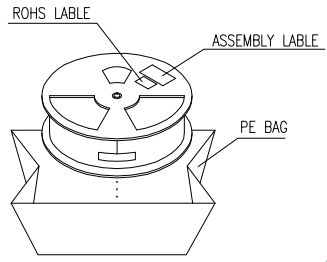
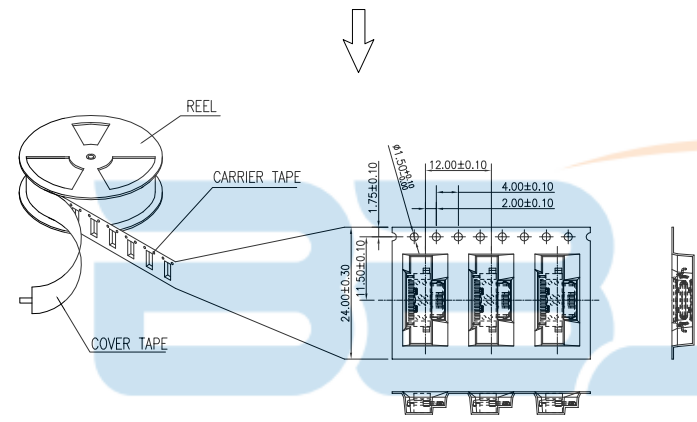
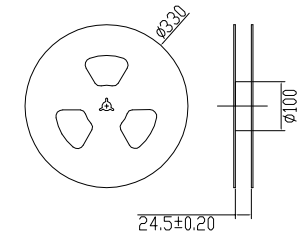
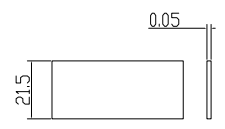
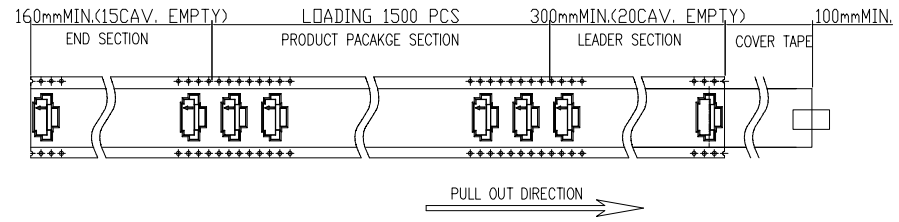

NOTES 2:

1. MATERIAL:

- 1.1 REEL AND AXLE: PS, BLUE
- 1.2 CARRIER TAPE: PET, LUCID
- 1.3 COVER TAPE: PS, TRANSPARENT
- 1.4 SHIPPING CARTON: CORRUGATED FIBER

2. DIMENSION:

- 2.1 REEL: W=24.5, ØA=330
- 2.2 CARRIER TAPE: T=0.50 W=24.0
- 2.3 COVER TAPE: T=0.05 W=21.3
- 2.4 SHIPPING CARTON: L=335mm, W=335mm, H=425mm

3. QUANTITY :

- 3.1 PRIMAY PACKING: 1500PCS/REEL
- 3.2 SECONARY PACKING: 12 REELS/CARTON (18000PCS/CARTON)

4. PEELING RESISTANCE: 0.1~1.3N

- 4.1 PEELING SPEED: 300mm/minutes
- 4.2 PEELING ANGLE: 165° ~180°



公差尺寸表 Tolerance	
X. ±0.50	X.* ±2*
.X ±0.30	.X* ±1*
.XX ±0.15	.XX* ±0.5*
.XXX ±0.05	

深圳市步步精科技有限公司

TITLE:
TYPE-C 16P 母座 四脚插 沉板1.68 L=3.0 舌片外露2.45 端子SMT

DRAWN/ DATE	设计 LHC	SIZE:A4	UNIT:MM.	PART.NO: 126-221-160014-H8G
CHECKED/ DATE	审核 LYX	SCALE: 1:1	PROJECTION	REV.: 版本
APPROVED/ DATE	核准 LJP	DWG. PATH	0482-1	SHEET: 页码