

REV.	ECN NO	CONTENT	DATE	ENGINEER
A0		Initial release	/	TSP

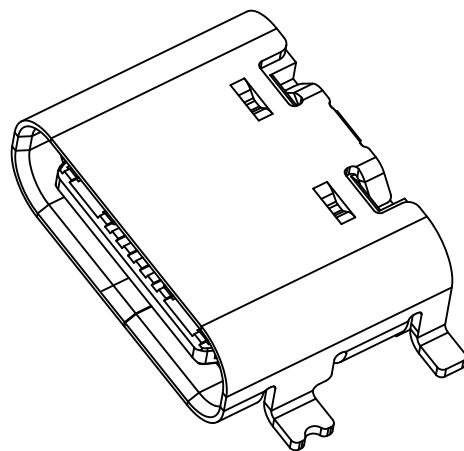

特性:

- 一、电气性能: ELECTRICAL
 1. 额定电流: 5.0A
 2. 接触阻抗: 30 MILLIOHMS MAX
 3. 耐电压: 100V AC / 1 mA MAX
 4. 绝缘阻抗: 150V DC/100 MEGA OHMS MIN
- 二、机械性能: MECHANICAL
 1. 插入力: 5~20N
 2. 拔出力: 8~20N
 3. 使用寿命: 10000次、拔出力 6N~20N
- 三、材料: MATERIAL
 1. 塑胶: LCP UL94V-0
 2. 端子: C7025 T=0.15MM
 3. 外壳: SUS304 T=0.30MM
 4. 卡勾: SUS301 T=0.15MM
- 四、电镀: FINISH
 1. 端子: 接触点镀金1U~MIN
PIN脚焊接区域镀金1U~MIN.
 2. 外壳: 镀镍50U~MIN (盐雾48H)
- 五、电镀品需做粘锡测试: 粘锡面积达到95%以上.
- 六、SMT回流焊(峰值260° C±5° C) 不能起泡、熔胶、变色不良(变形在公差范围以内)
- 七、工作温度: -40° C~+85° C

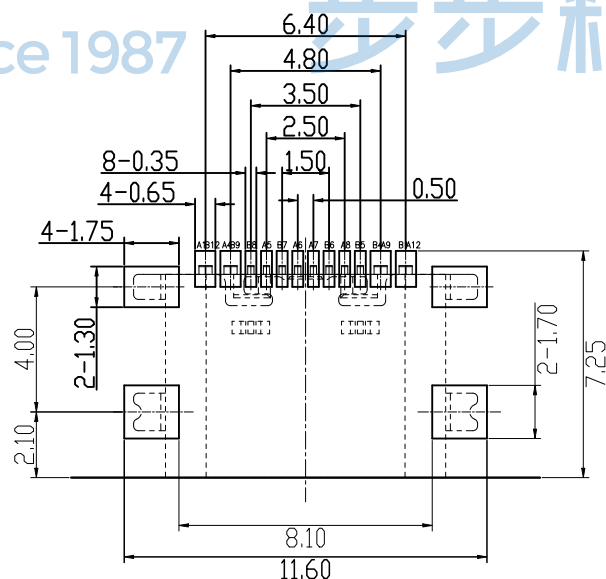
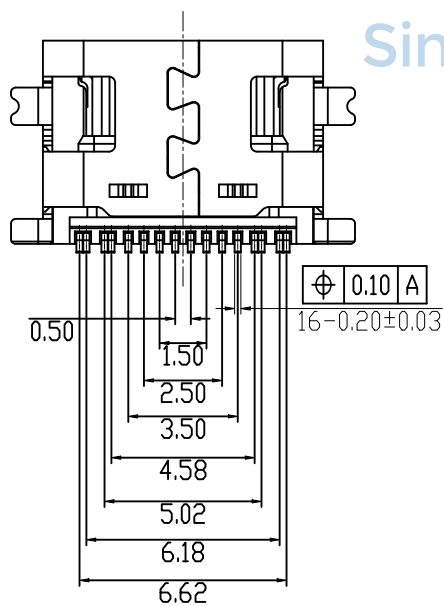
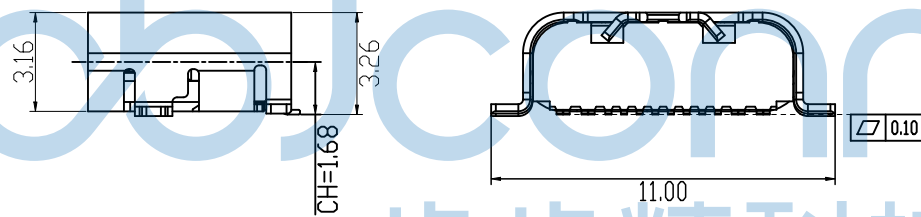
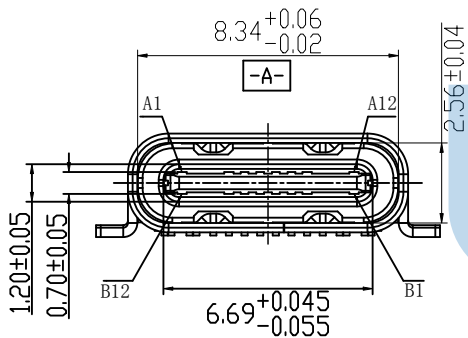
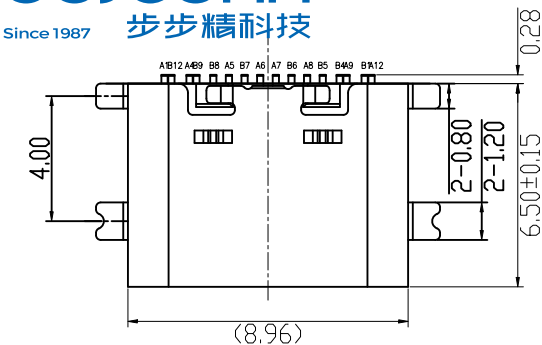

RECOMMENDED PCB LAYOUT (TOP VIEW)
THICKNESS 0.80MM; DEFAULT TOLERANCE: ±0.05

USB TYPE-C 16PIN PIN ASSIGNMENTS

PIN NUMBER	A1	A2	A3	A4	A5	A6	A7	A8	A9	A10	A11	A12
SIGNAL NAME	GND			Vbus	CC1	Dp1	Dn1	SBU1	Vbus			GND
PIN NUMBER	B12	B11	B10	B9	B8	B7	B6	B5	B4	B3	B2	B1
SIGNAL NAME	GND			Vbus	SBU2	Dn2	Dp2	CC2	Vbus			GND

THIS DOCUMENT IS THE SOLE PROPERTY OF BBJconn Technology Co., Ltd. Corporation AND SHOULD NOT BE USED IN WHOLE OR IN PART WITHOUT PRIOR WRITTEN PERMISSION.

PDWG.NO: 0482-1

DR. TSP

APPD. JM_Zheng

CHKD. LYX

NAME: TYPE-C 16PIN 母座 板上四脚全贴 端子SMT L=6.50 CH=1.68 编带

PJ. NO.: 126-221-160018-H8G

SIZE: A4 DRW NO.:

FINISH: SEE NOTES MAT'L.: SEE NOTES

SCALE: N/A REV.: A0 UNIT: mm PAGE: 1/2

REV.	ECN NO	CONTENT	DATE	ENGINEER
A0		Initial release	/	TSP

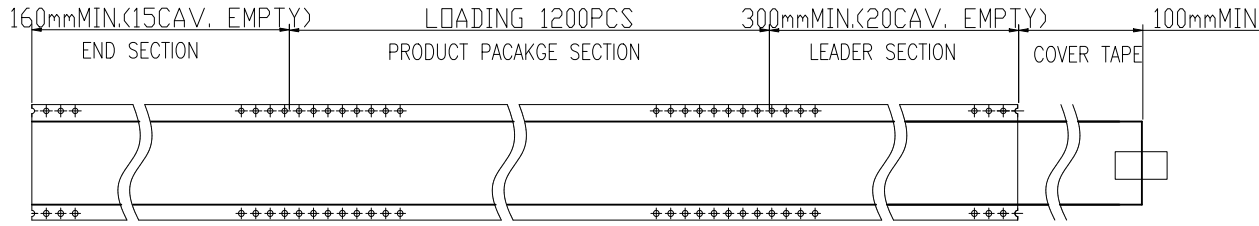

NOTES 2:

- MATERIAL:
 - 1 REEL AND AXLE:PS, BLUE
 - 2 CARRIER TAPE:PET, LUCID
 - 3 COVER TAPE:PS, TRANSPARENT
 - 4 SHIPPING CARTON:CORRUGATED FIBER
- DIMENSION:
 - 2.1 REEL: W=24.5, ØA=330
 - 2.2 CARRIER TAPE:T=0.30 W=24.0
 - 2.3 COVER TAPE:T=0.05 W=21.5
 - 2.4 SHIPPING CARTON:L=335mm, W=335mm, H=425mm
- QUANTITY:
 - 3.1 PRIMAY PACKING:1200PCS/REEL
 - 3.2 SECONARY PACKING:12 REELS/CARTON(14400PCS/CARTON)
- PEELING RESISTANCE:0.1~1.3N
 - 4.1 PEELING SPEED:300mm/minutes
 - 4.2 PEELING ANGLE:165° ~180°

PULL OUT DIRECTION →

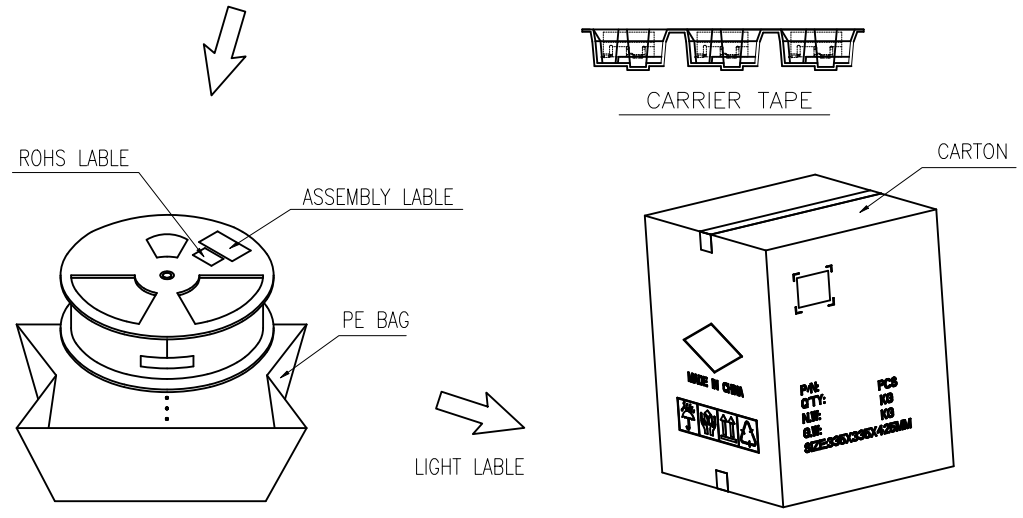
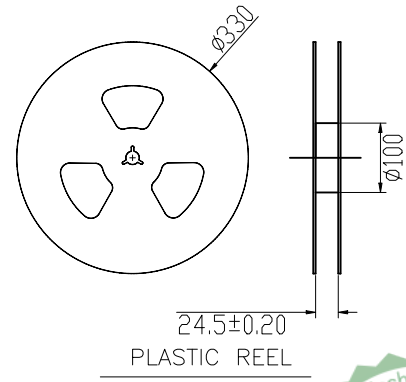
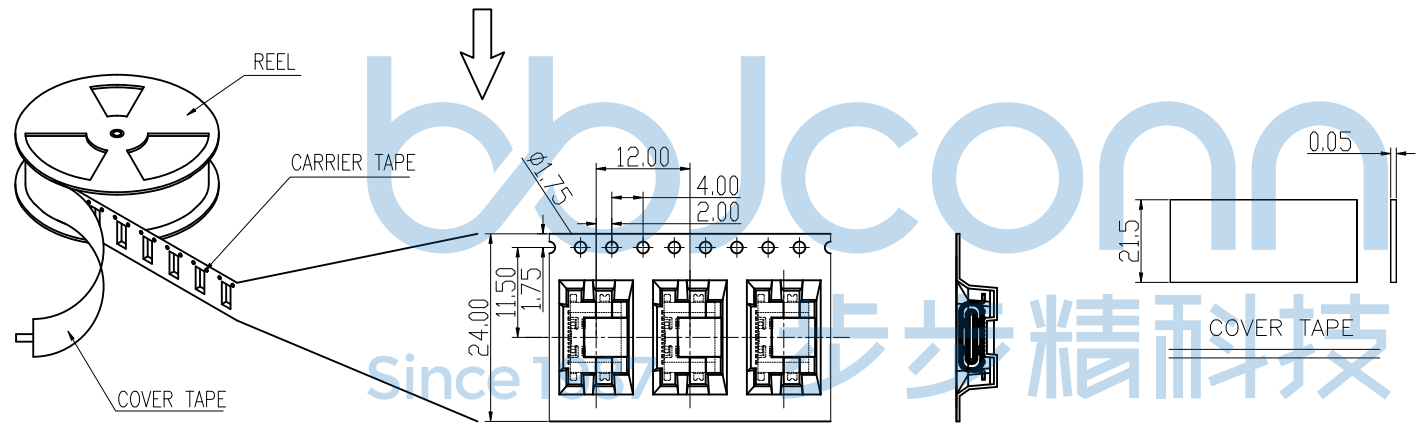

THIS DOCUMENT IS THE SOLE PROPERTY OF BBJconn Technology Co.,Ltd. Corporation AND SHOULD NOT BE USED IN WHOLE OR IN PART WITHOUT PRIOR WRITTEN PERMISSION.		深圳市步步精科技有限公司 工程部	
.X: ±0.38 .XX: ±0.25 .XXX: ±0.13		X': ±3" .X': ±2" .XX': ±1"	
APPD.	JM_Zheng	NAME: TYPE-C 16PIN 母座 板上四脚全贴 端子SMT L=6.50 CH=1.68 编带	
CHKD.	LYX	PJ. NO.: 126-221-160018-H8G	
DR.	TSP	SIZE: A4 DRW NO.:	
PDWG.NO:	0482-1	FINISH: SEE NOTES MAT'L.: SEE NOTES	
		SCALE: N/A	REV.: A0 UNIT: mm PAGE: 2/2