

REV.	ECN NO	CONTENT	DATE	ENGINEER
A0		Initial release	/	SGF

NOTE:

- MATERIAL SPECIFICATION:
  - HOUSING: HIGH TEMPERATURE RESISTANT PLASTIC, UL94 V-0.
  - CONTACTS: COPPER ALLOY
  - MID PLATE: STAINLESS STEEL
  - FRONT SHELL: STAINLESS STEEL
- PLATING SPECIFICATION:
  - CONTACTS:
    - Ni 50u" MIN. UNDER PLATED OVER ALL.
    - Au PLATED ON THE FUNCTIONAL AREA OF CONTACT.
    - (GOLD PLATING THICKNESS FOLLOW THE P/N)
    - PLATING SPECIFICATIONS OF THE SOLDER AREA FOLLOW THE P/N
- MECHANICAL PERFORMANCE:
  - INSERTION FORCE: 0.5~2.0kgf.
  - REMOVAL FORCE: 0.8kgf~2.0kgf.
  - DURABILITY: 10000 CYCLES.
- ELECTRICAL PERFORMANCE:
  - CURRENT RATING: 3.0A  
VOLTAGE RATING: 5.0V
  - LLCR:
    - VBUS & GND PINS AND OTHER PINS: 40MΩ/PIN MAX.
    - SHIELD: 50MΩ/MAX.
    - LLCR MAX. CHANGE OF ALL PINS: 10MΩ.
  - INSULATION RESISTANCE: 100MΩ MIN
  - DIELECTRIC WITHSTAND VOLTAGE, AC 100V FOR 1 MINUTE.
- ENVIRONMENTAL PERFORMANCE:
  - OPERATING TEMPERATURE: -25°C~+85°C.
  - IR REFLOW:
    - THE PEAK TEMPERATURE ON THE BOARD SHALL BE MAINTAINED FOR 10 SECONDS AT 260° C.

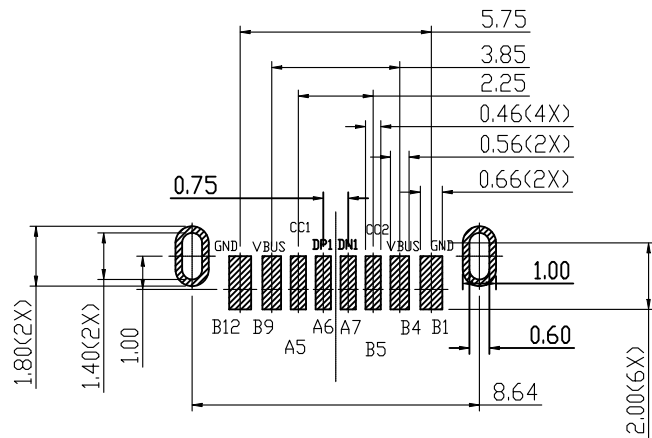
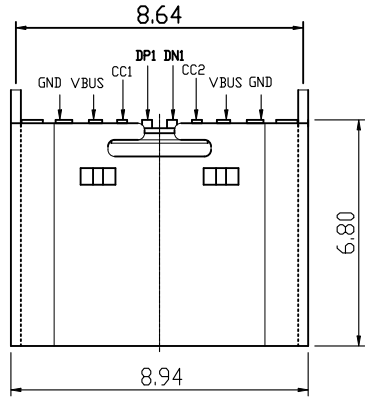

PCB参考图

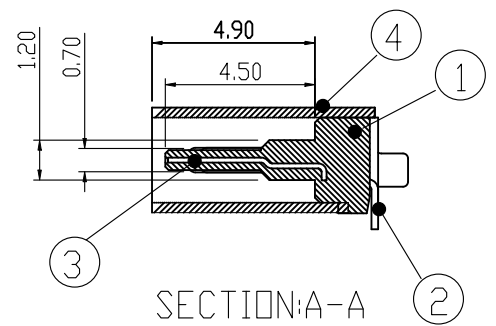
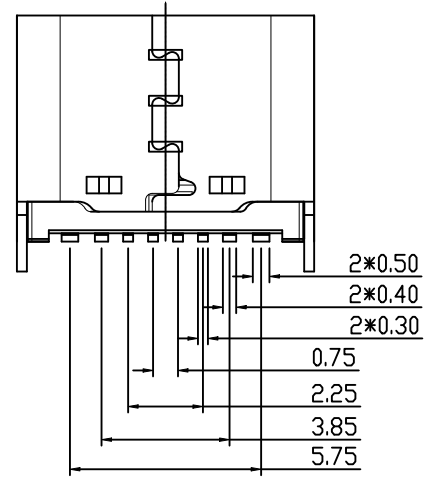
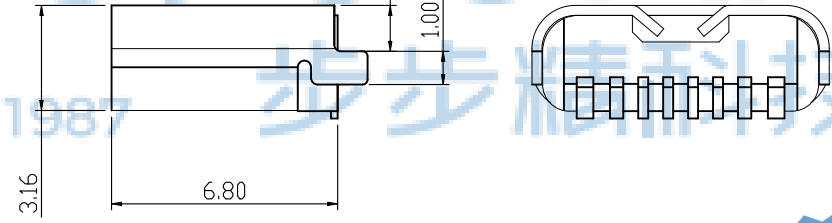
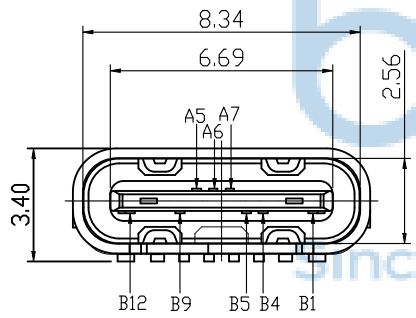

USB TYPE-C PIN ASSIGNMENTS											
A1	A2	A3	A4	A5	A6	A7	A8	A9	A10	A11	A12
/	/	/	/	CC1	DP1	DN1	/	/	/	/	/
GND	/	/	VBUS	/	/	/	CC2	VBUS	/	/	GND
B12	B11	B10	B9	B8	B7	B6	B5	B4	B3	B2	B1

THIS DOCUMENT IS THE SOLE PROPERTY OF BBJconn Technology Co., Ltd. Corporation AND SHOULD NOT BE USED IN WHOLE OR IN PART WITHOUT PRIOR WRITTEN PERMISSION.

PDWG.NO: 0482-1

**深圳市步步精科技有限公司**

NAME:	TYPE-C 8P 母座 直立式 两脚插 端子SMT H=6.80 带中夹片 编带
APPD:	JM_Zheng
CHKD:	LYX
DR:	SGF
PJ. NO.:	126-224-080002-H8G
SIZE:	A4 DRW NO.:
FINISH:	SEE NOTES
MAT'L.:	SEE NOTES
SCALE:	N/A
REV.:	A0
UNIT:	mm
PAGE:	1/2

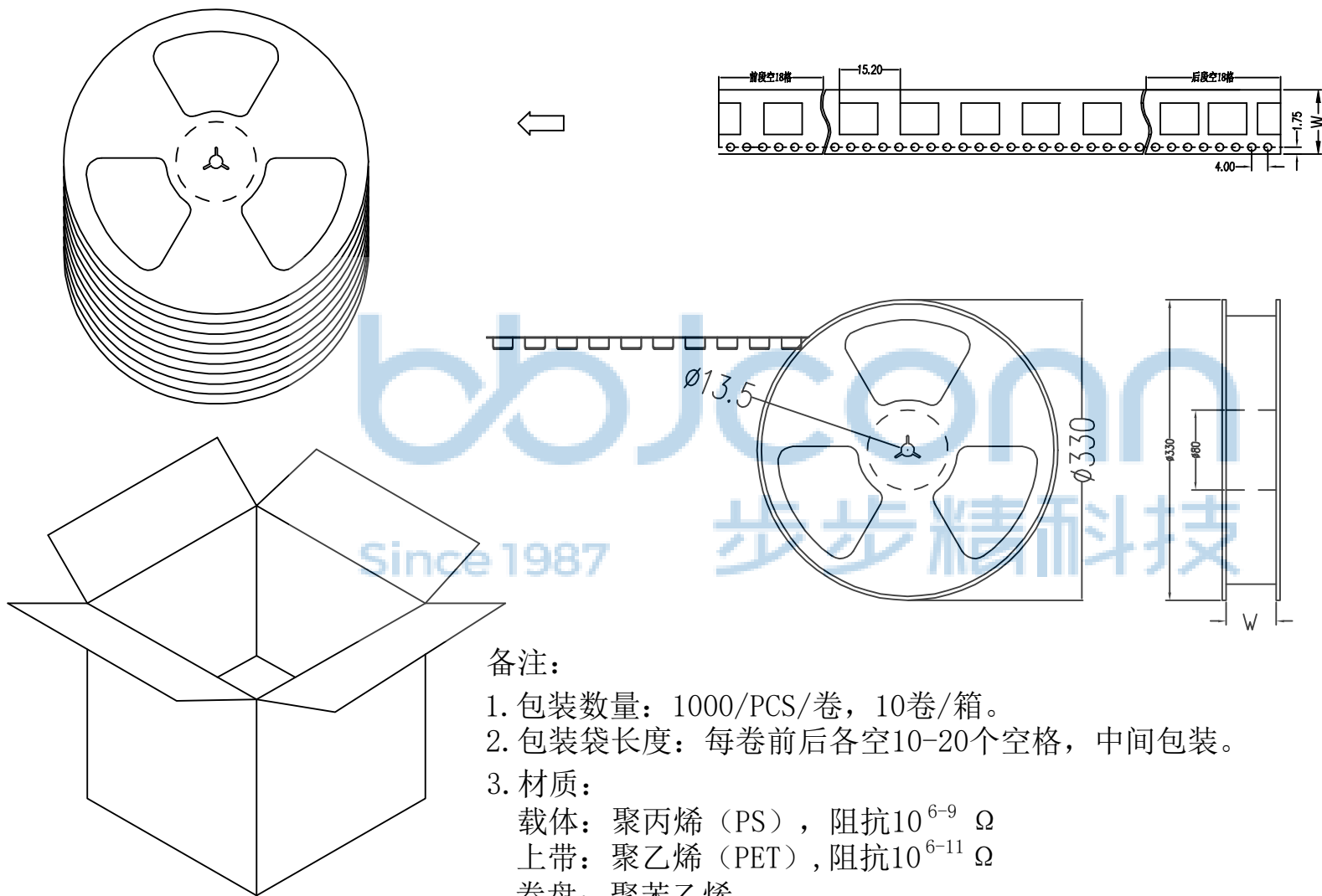

备注:

1. 包装数量: 1000/PCS/卷, 10卷/箱。
2. 包装袋长度: 每卷前后各空10-20个空格, 中间包装。
3. 材质:  
载体: 聚丙烯 (PS), 阻抗 $10^{6-9} \Omega$   
上带: 聚乙烯 (PET), 阻抗 $10^{6-11} \Omega$   
卷盘: 聚苯乙烯。

纸箱规格: 345\*345\*230MM  
纸箱规格: 345\*345\*350MM

THIS DOCUMENT IS THE SOLE PROPERTY OF BBJconn Technology Co., Ltd. Corporation AND SHOULD NOT BE USED IN WHOLE OR IN PART WITHOUT PRIOR WRITTEN PERMISSION.		深圳市步步精科技有限公司	
.X: $\pm 0.38$ .XX: $\pm 0.25$ .XXX: $\pm 0.13$ X': $\pm 3'$ X'': $\pm 2'$ X'': $\pm 1'$		NAME: TYPE-C 8P 母座 直立式 两脚插 端子SMT H=6.80 带中夹片 带带	
APPD.	JM_Zheng	PJ. NO.: 126-224-080002-H8G SIZE: A4 DRW NO.:	FINISH: SEE NOTES   MAT'L.: SEE NOTES
CHKD.	LYX		
PDWG.NO:	0482-1	SCALE: N/A	REV.: AO   UNIT: mm   PAGE: 2/2