

REV.	ECN NO.	CONTENT	DATE	ENGINEER
A0		Initial release	/	TSP

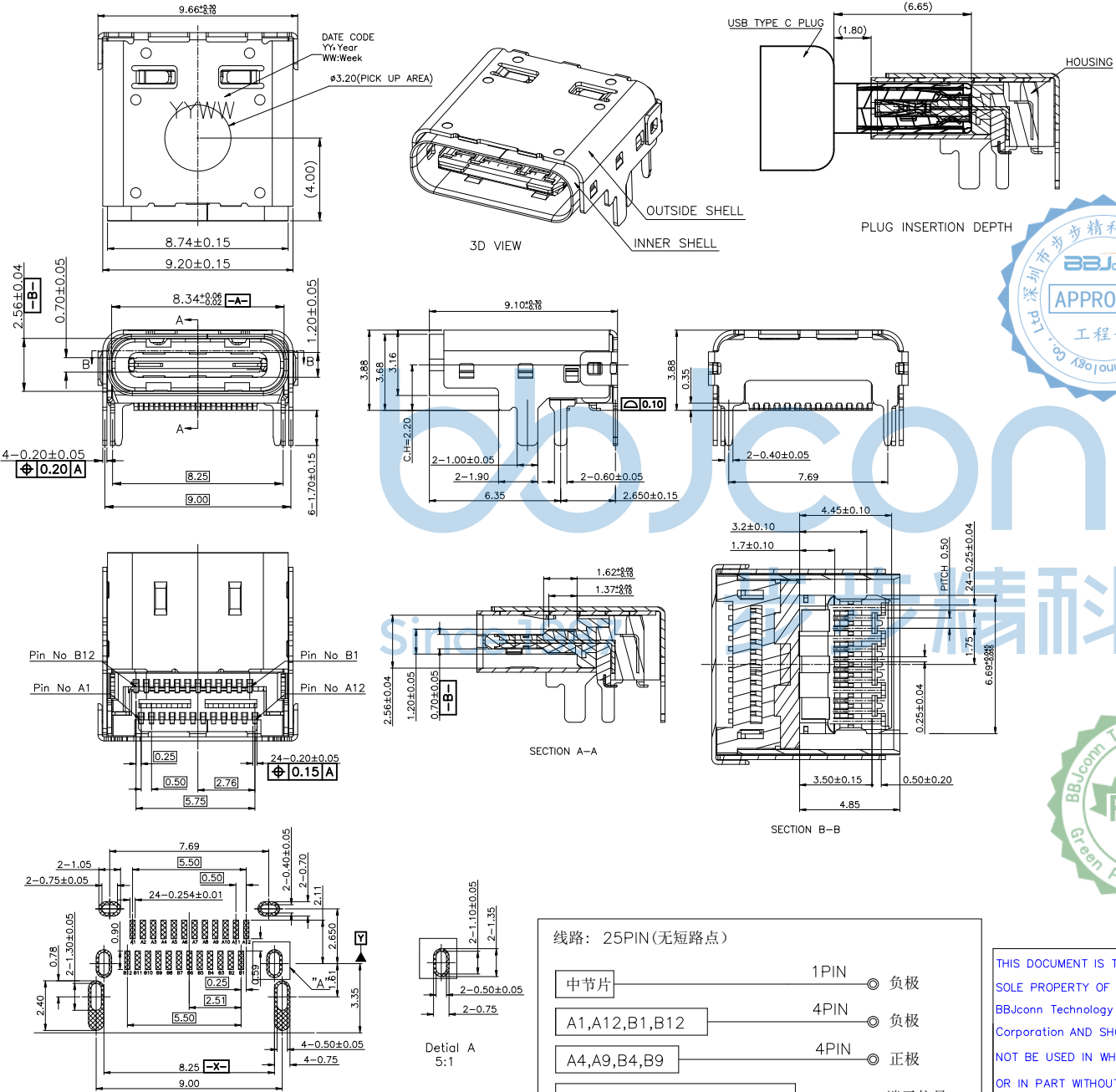

- NOTES:
- MATERIAL:
    - OUTSIDE SHELL: SUS201 T=0.20mm
    - INNER SHELL: SUS201 T=0.20mm
    - SIGNAL: SUS201 T=0.15mm
    - HOUSING: LCP UL94V-0 BLACK
    - TERMINAL: C19400-H
  - PLATING:
    - TERMINAL: GOLD FLASH IN CONTACT AREA, MATTE TIN PLATED IN SOLDER AREA, NICKEL UNDERPLATED OVERALL.
    - SHELL: 50 $\mu$ M NICKEL PLATED
  - ELECTRICAL CHARACTERISTICS:
    - CURRENT RATING: 5.0 A  
VOLTAGE RATING: 20.0 V
    - LLCR: VBUS & GND PINS: 40m $\Omega$ /PIN MAX  
OTHER PINS: 40m $\Omega$ /PIN MAX  
CHANGE OF ALL PINS: 10m $\Omega$
    - INSULATION RESISTANCE: 100M $\Omega$  MIN.
  - MECHANICAL CHARACTERISTICS:
    - INSERTION FORCE: 0.5~2.0kg.
    - WITHDRAWAL FORCE: 0.8~2.0kg.  
(INITIAL: 1000 CYCLES) 0.6~2.0kg. (AFTER LIFE TEST)
  - LIFE TEST: 10000 CYCLES MIN
  - ALL COMPONENTS ARE RoHS2.0 COMPLIANT.
  - RESISTANCE TO SOLDERING HEAT: 265°C FOR 10 SECONDS,



USB TYPE-C PIN ASSIGNMENTS:

A12	GND	B1	GND
A11	SSRXp2	B2	SSTXp2
A10	SSRXn2	B3	SSTXn2
A9	VBUS	B4	VBUS
A8	SBU1	B5	CC2
A7	Dn1	B6	Dp2
A6	Dp1	B7	Dn2
A5	CC1	B8	SBU2
A4	VBUS	B9	VBUS
A3	SSTXn1	B10	SSRXn1
A2	SSTXp1	B11	SSRXp1
A1	GND	B12	GND
PIN	SIGNAL NAME	PIN	SIGNAL NAME

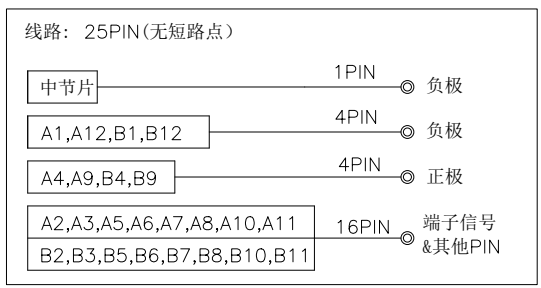

THIS DOCUMENT IS THE SOLE PROPERTY OF BBJconn Technology Co., Ltd. CORPORATION AND SHOULD NOT BE USED IN WHOLE OR IN PART WITHOUT PRIOR WRITTEN PERMISSION.

PDWG.NO: 0643-2

APPD. JM\_Zheng

CHKD. LYX

DR. TSP

**深圳市步步精科技有限公司**

NAME: TYPE-C 24P 母座 板上六脚插 端子双排SMT 双壳 L=9.10 CH=2.20 编带

PJ. NO.: 126-221-240025-J8G

SIZE: A4 DRW NO.:

FINISH: SEE NOTES MAT'L.: SEE NOTES

SCALE: N/A REV.: A0 UNIT: mm PAGE: 1/2

RECOMMENDED P.C.B LAYOUT(PCB THICKNESS: 1.6mm)  
COMPONENT SIDE VIEW(TOLERANCE: ±0.05)



REV.	ECN NO.	CONTENT	DATE	ENGINEER
A0		Initial release	/	TSP

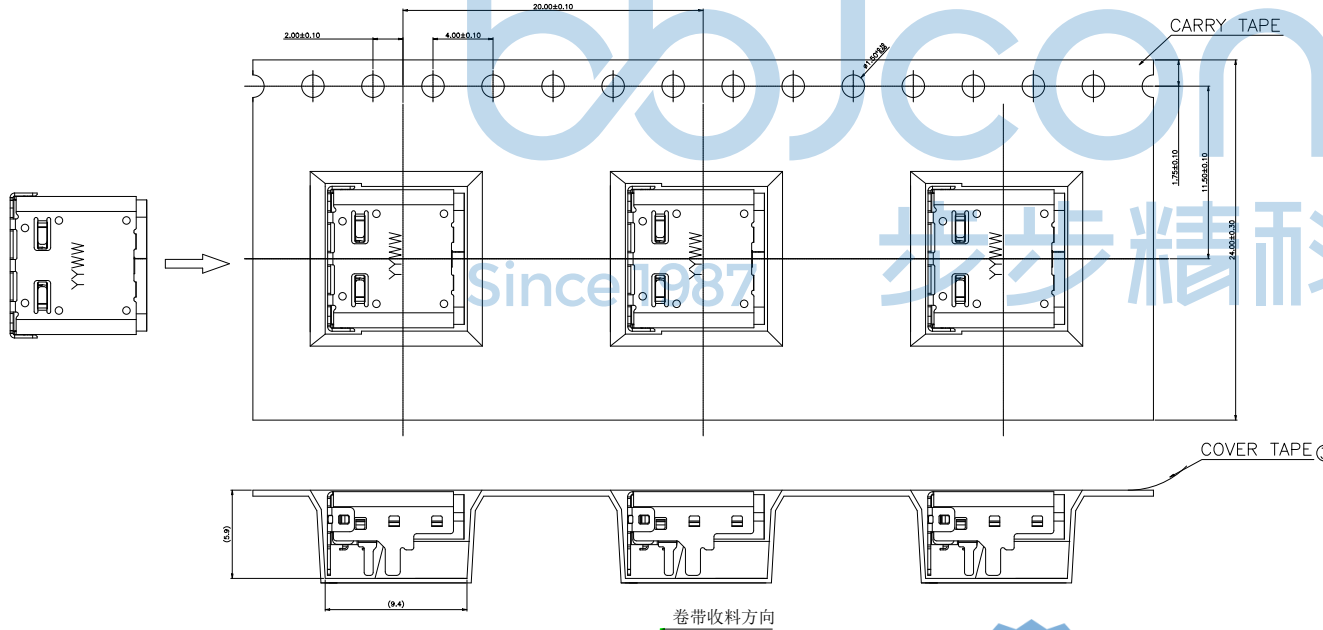
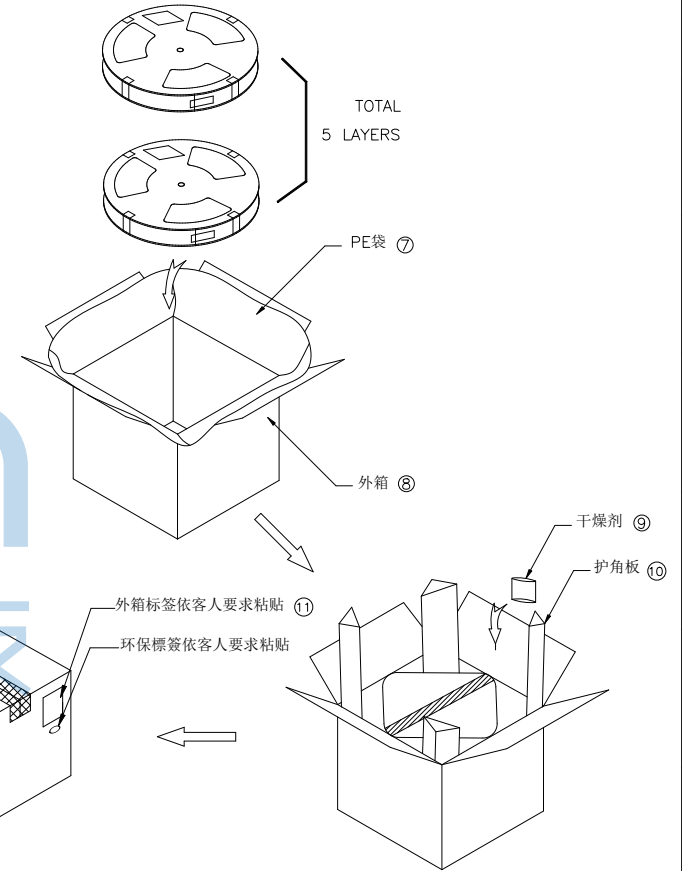
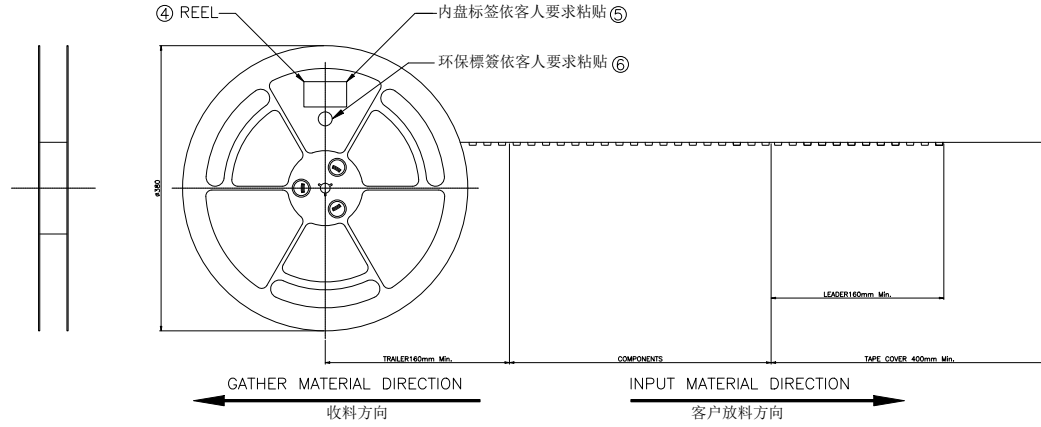

- Notes:
- 每卷带的开始端留160mm以上空格不装产品(参考量: 15PCS), 以实际包装数量装满后, 结束端预留160mm以上空格不装产品(参考量: 15PCS)
  - 卷带用自封胶带封口, 1个卷盘放置650PCS产品;
  - 再绕一圈环保带, 环保带最后重叠约50mm, 每个卷盘须贴一张条码标签和无卤标签(或依客人要求粘贴);
  - 将PE袋套入外箱后, 将5盘装好产品的卷盘依次放入纸箱, 并在纸箱封角各放入干燥剂一袋;
  - 外箱外侧以胶带封口, 每个外箱外侧图示位置贴一张条码标签和无卤标签(或依客人要求粘贴);
  - COVER TAPE与CARRY TAPE剥离力: 35g~110g; 剥离角度: 165°~175°; 剥离速度: 250~300mm/min;
  - 包装数量: 650PCS/REEL, 5REEL/CARTON, 共3250PCS/CARTON;
  - 此部品必须符合厂内《环境管理物质管控标准》要求。



THIS DOCUMENT IS THE SOLE PROPERTY OF BBJconn Technology Co., Ltd. Corporation AND SHOULD NOT BE USED IN WHOLE OR IN PART WITHOUT PRIOR WRITTEN PERMISSION.		<b>深圳市步步精科技有限公司</b>	
PDWG.NO: 0643-2		.X: ±0.38 .XX: ±0.25 .XXX: ±0.13	X*: ±3" .X*: ±2" .XX*: ±1"
APPD.	JM_Zheng	NAME TYPE-C 24P 母座 板上六脚插 端子双排SMT 双壳 L=9.10 CH=2.20 编带	
CHKD.	LYX	PJ. NO.: 126-221-240025-J8G	
DR.	TSP	SIZE: A4 DRW NO.:	
		FINISH: SEE NOTES	MAT'L.: SEE NOTES
		SCALE: N/A	REV.: A0 UNIT: mm PAGE: 2/2