

REV.	ECN NO.	CONTENT	DATE	ENGINEER
A0		Initial release	/	TSP

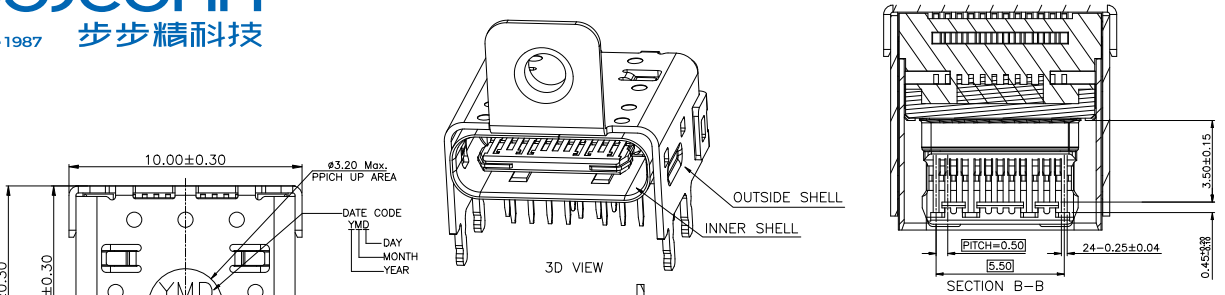

- NOTES:
- MATERIAL:
 - OUTSIDE SHELL: SUS304-1/4H T=0.25mm
 - INNER SHELL: SUS301-1/2H T=0.20mm
 - MID PLATE: SUS301-H T=0.15mm
 - HOUSING: PA9T+45%GF UL94V-0
 - DIP-TERMINARL: C7025 T=0.12mm
 - SMT-TERMINARL: C19400 T=0.12mm
 - PLATING:
 - TERMINAL: SEE PIN
 - SHELL: NICKEL PLATED 50μMIN.
 - ELECTRICAL CHARACTERISTICS:
 - CURRENT RATING: 5.0 A
VOLTAGE RATING: 20.0 V
 - LLCR: VBUS& GND PINS: 40mΩ/PIN MAX
OTHER PINS : 40mΩ/PIN MAX
LLCR MAX. CHANGE OF ALL PINS: 10mΩ
 - INSULATION RESISTANCE: 100MΩ MIN.
 - MECHANICAL CHARACTERISTICS:
 - INSERTION FORCE: 0.5~2.0kg.
 - WITHDRAWAL FORCE: 0.8~2.0kg.(INITIAL) 0.6~2.0kg.(AFTER LIFE TEST)
 - LIFE TEST: 10000 CYCLES MIN

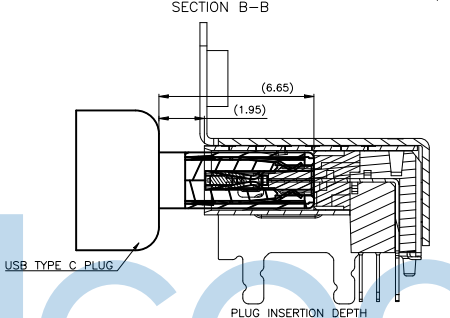
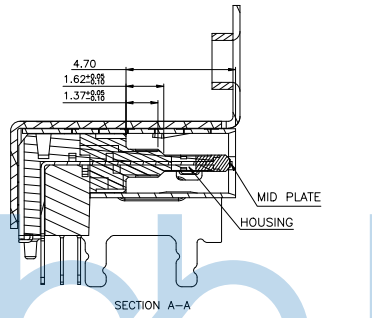
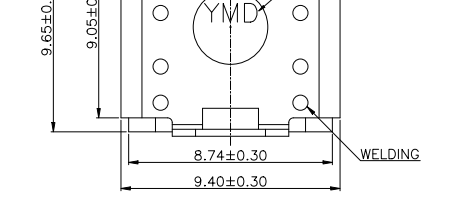

USB TYPE-C PIN ASSIGNMENTS:

A12	GND	B1	GND
A11	SSRXp2	B2	SSTXp2
A10	SSRXn2	B3	SSTXn2
A9	VBUS	B4	VBUS
A8	SBU1	B5	CC2
A7	Dn1	B6	Dp2
A6	Dp1	B7	Dn2
A5	CC1	B8	SBU2
A4	VBUS	B9	VBUS
A3	SSTXn1	B10	SSRXn1
A2	SSTXp1	B11	SSRXp1
A1	GND	B12	GND
PIN	SIGNAL NAME	PIN	SIGNAL NAME

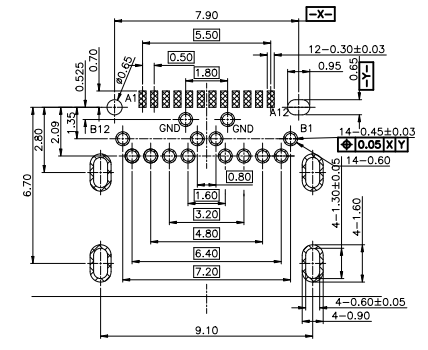
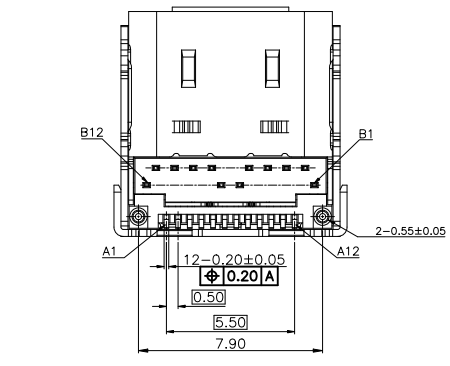
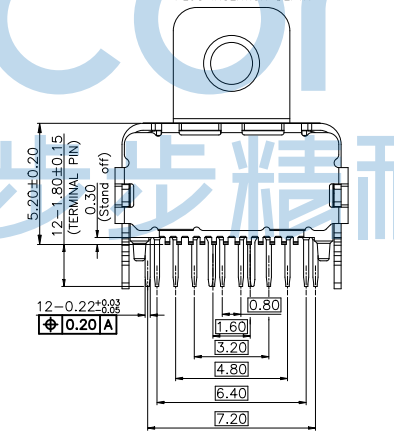
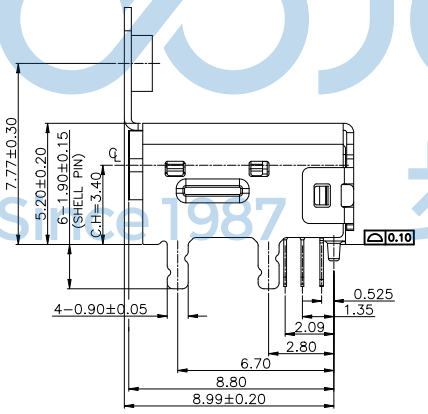
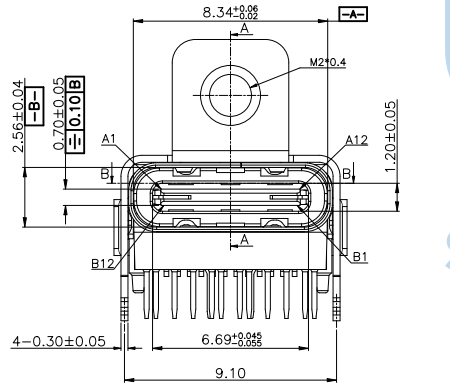

RECOMMENDED PCB LAYOUT(TOP VIEW)
(TOLERANCE=±0.05mm)

THIS DOCUMENT IS THE
SOLE PROPERTY OF
BBJconn Technology Co.,Ltd.
CORPORATION AND SHOULD
NOT BE USED IN WHOLE
OR IN PART WITHOUT
PRIOR WRITTEN PERMISSION.
PDWG.NO: 0643-2

深圳市步步精科技有限公司

NAME: TYPE-C 24P 母座 板上四脚插 带柱 端子SMT+DIP
L=9.65 CH=3.40 锁螺丝 显卡专用

APPD.	JM_Zheng	PJ. NO.:	126-223-240009-J8G
CHKD.	LYX	SIZE:	A4 DRW NO.:
DR.	TSP	FINISH:	SEE NOTES
		MAT'L.:	SEE NOTES
		SCALE:	N/A
		REV.:	A0
		UNIT:	mm
		PAGE:	1/2



REV.	ECN NO.	CONTENT	DATE	ENGINEER
A0		Initial release	/	TSP

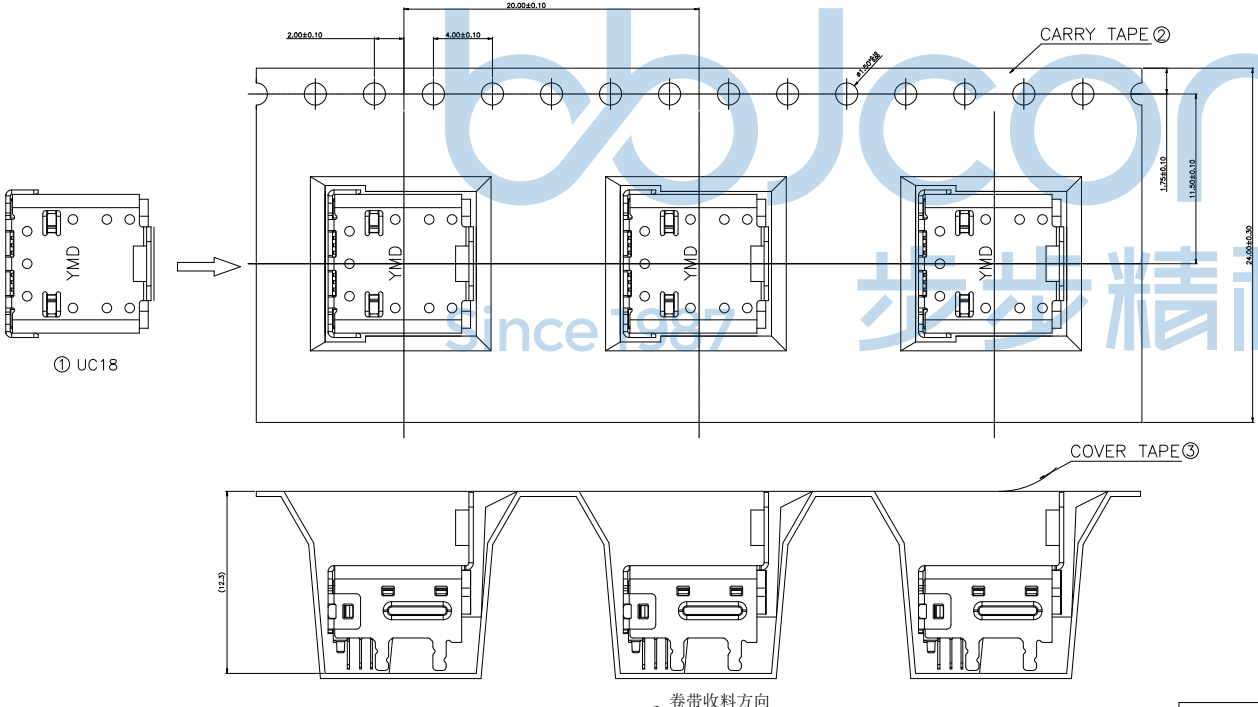
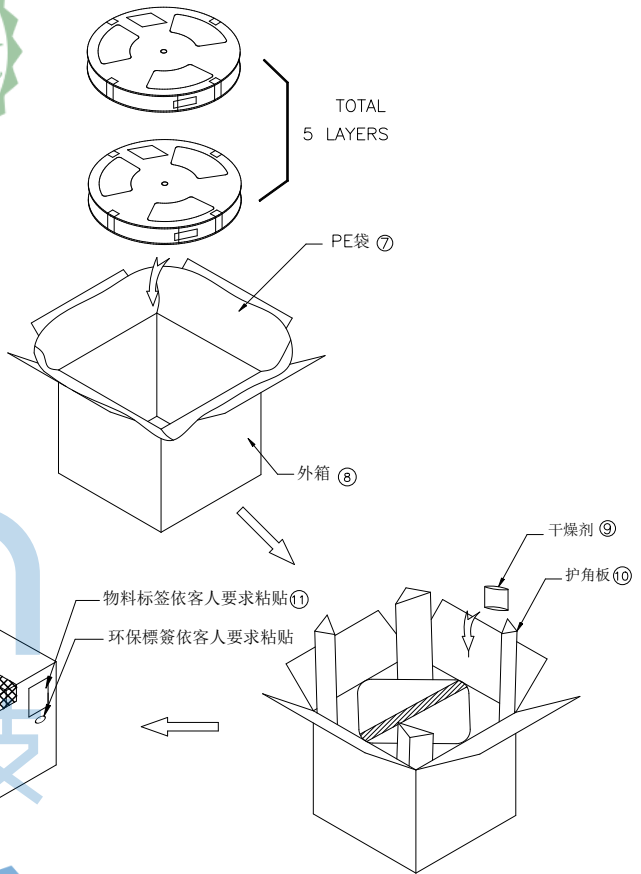
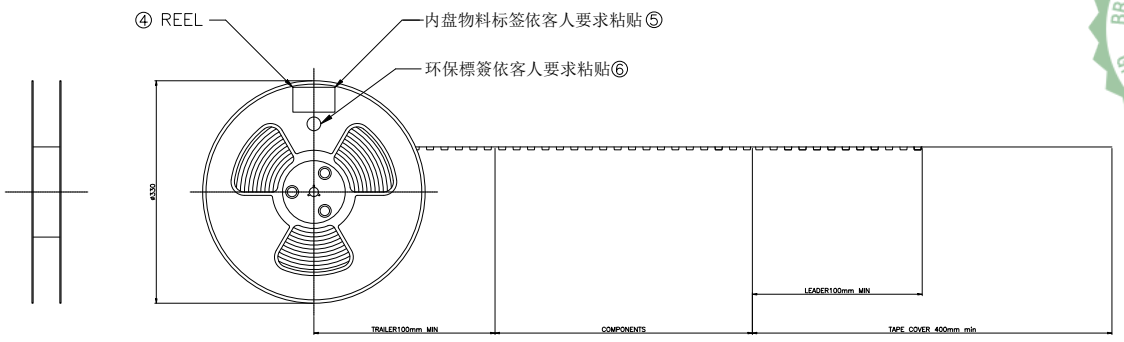

项目	品名	规格	数量
①	0826	USB TYPE C母座	1200PCS
②	CARRY TAPE	W=24mm P=20mm L=5.4m	5SET
③	COVER TAPE	W=20.7mm	80m
④	REEL	D=φ13" x24mm	5PCS
⑤	内盘标签	—	5PCS
⑥	环保标签	φ20x13mm	6PCS
⑦	PE袋	(400+250)x500x0.06mm	1PCS
⑧	外箱	350x350x165mm K=K	1PCS
⑨	干燥剂	—	2PCS
⑩	护角板	100x100x140mm B=B	4PCS
⑪	外箱标签	—	1PCS

- Notes:
- 每卷卷带的开始端留160mm以上空格不装产品 (参考值: 15PCS), 以实际包装数量装满后, 结束端预留160mm以上空格不装产品 (参考值: 15PCS)
 - 卷带用自封胶带封口, 1个卷盘放置240PCS产品;
 - 再绕一圈保护带, 保护带最后重量约50mm, 每个外箱外侧标签依客人要求粘贴;
 - 将PE袋套入外箱后, 将5盘装好产品的卷盘依次放入纸箱, 并在纸箱封角各放入干燥剂一袋;
 - 外箱外侧以胶带封口, 每个外箱外侧标签依客人要求粘贴;
 - COVER TAPE與CARRY TAPE剝離力: 20g~120g; 剝離角度: 165°~175°; 剝離速度: 250~300mm/min;
 - 包装数量: 240PCS/REEL, 5REEL/CARTON, 共1200PCS/CARTON;
 - 此部品必须符合《环境管理物质管控标准》要求。

THIS DOCUMENT IS THE SOLE PROPERTY OF BBJconn Technology Co., Ltd. CORPORATION AND SHOULD NOT BE USED IN WHOLE OR IN PART WITHOUT PRIOR WRITTEN PERMISSION.

PDWG.NO: 0643-2

APPD. JM_Zheng
CHKD. LYX
DR. TSP

深圳市步步精科技有限公司

NAME: TYPE-C 24P 母座 板上四脚插 带柱 端子SMT+DIP L=9.65 CH=3.40 锁螺丝 显卡专用

PJ. NO.: 126-223-240009-J8G
SIZE: A4 DRW NO.:
FINISH: SEE NOTES MAT'L.: SEE NOTES
SCALE: N/A REV.: A0 UNIT: mm PAGE: 2/2