

REV.	ECN NO.	CONTENT	DATE	ENGINEER
A0		Initial release	/	SGF

NOTE:
 1. MATERIAL:
 1.1 INSULATOR: HIGH TEMPERATURE PLASTIC UL 94V-0;
 1.2 CONTACT: COPPER ALLOY
 1.3 SHELL: STAINLESS STEEL
 2. PLATING
 2.1 TERMINAL CONTACT: (SEE TAB) SELECTIVE GOLD PLATING IN THE CONTACT AREA AND G/F PLATING IN THE SOLDER TAIL AREA WITH 50u" NICKEL UNDER PLATING OVERALL.
 2.2 SHELL: 30u" Min. NICKEL ALL OVER,

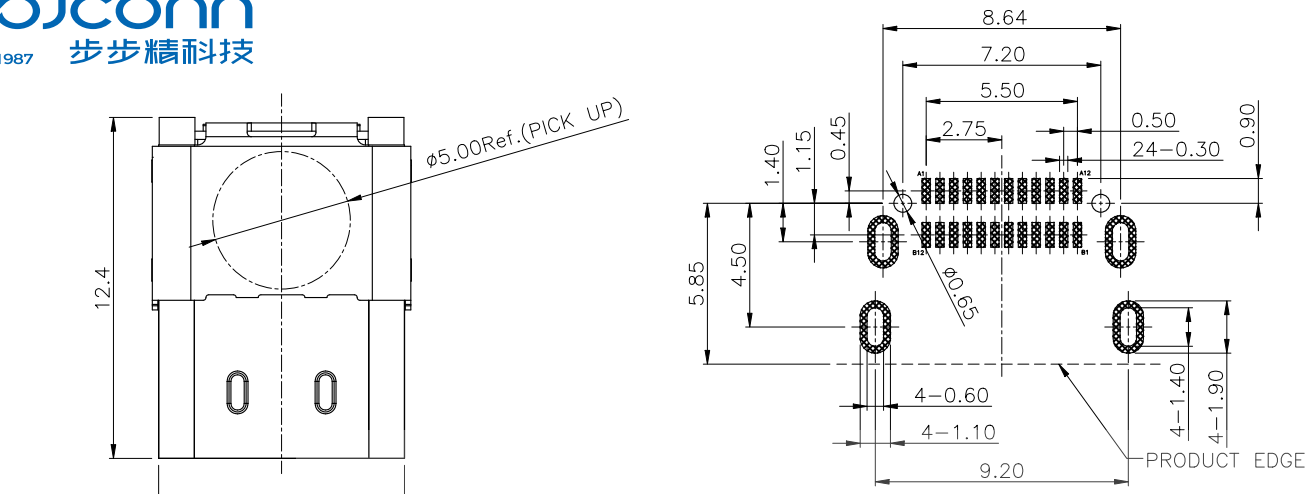

RECOMMENDED P.C.B LAYOUT (TOP VIEW)

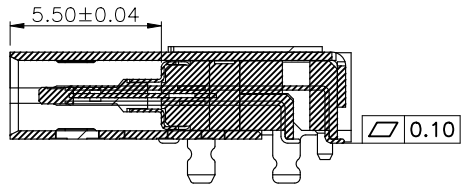
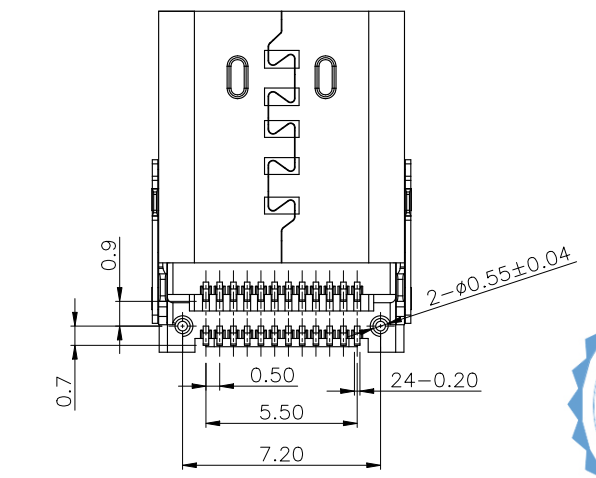
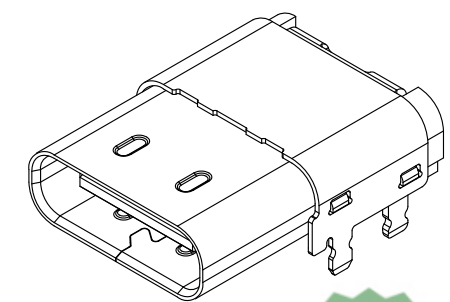
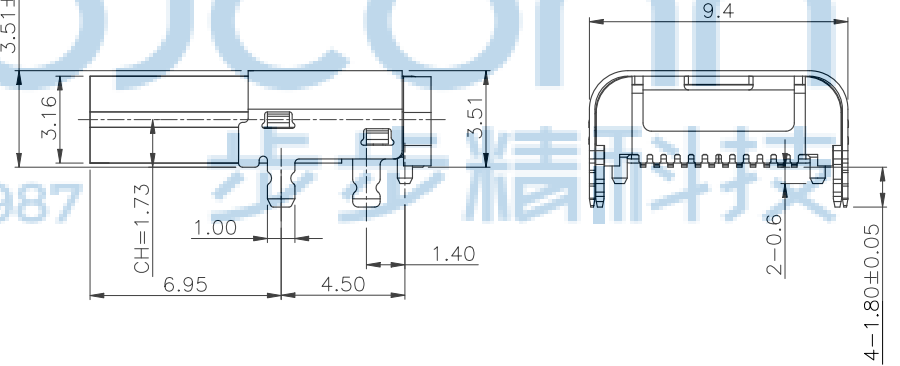
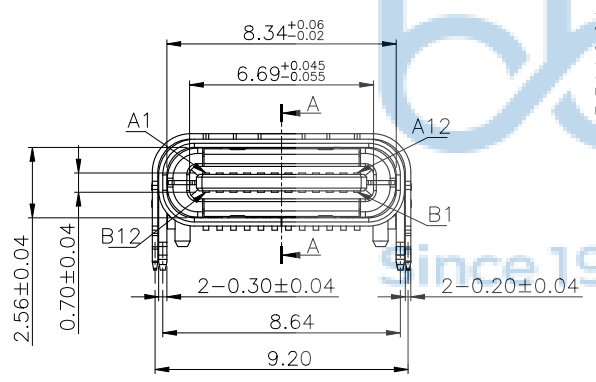

5	SHELL	SUS304 T=0.30	NI 30U" MIN	1PCS
4	SPRING	SUS304 T=0.10	---	2PCS
3	SHIELDING PLATE	SUS301 T=0.15	---	1PCS
2	CONTACT	C7025 T=0.15	Au 1U"/NI 50U" MIN	2SET
1	HOUSING	LCP	BLACK	1PCS



THIS DOCUMENT IS THE SOLE PROPERTY OF BBJconn Technology Co., Ltd. CORPORATION AND SHOULD NOT BE USED IN WHOLE OR IN PART WITHOUT PRIOR WRITTEN PERMISSION. PDWG NO: 0853-1

深圳市步步精科技有限公司

NAME: TYPE-C 24P 母座 双壳 板上四脚DIP 带柱 端子双排SMT L=12.4 CH=1.73 LCP黑胶 编带

PJ. NO.: 126-221-240002-N4G
 SIZE: A4 DRW NO.:
 FINISH: SEE NOTES MAT'L: SEE NOTES
 SCALE: N/A REV.: A0 UNIT: mm PAGE: 1/2

APPD. JM_Zheng
 CHKD. LYX
 DR. SGF

REV.	ECN NO.	CONTENT	DATE	ENGINEER
A0		Initial release	/	SGF

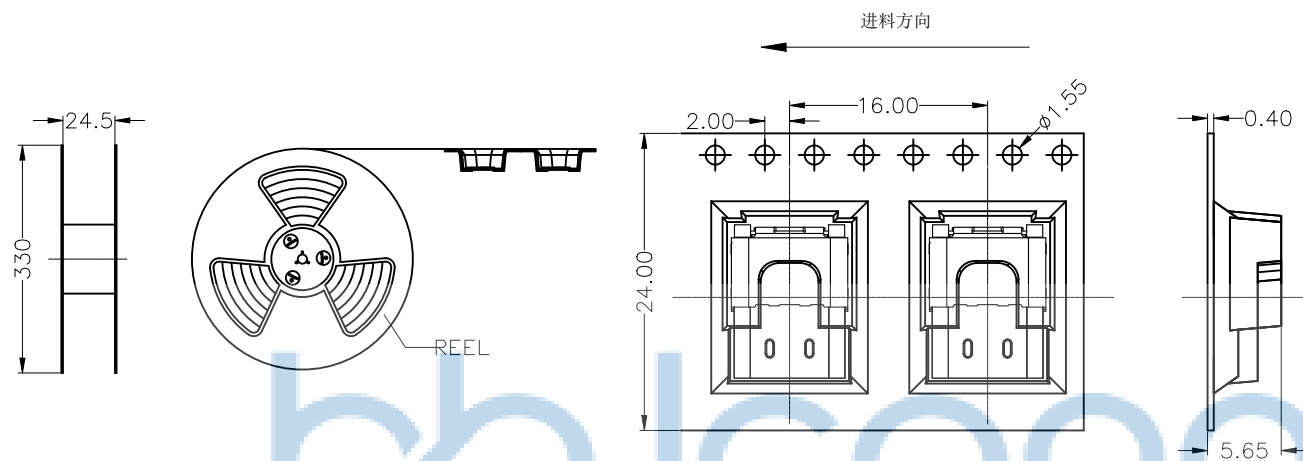

- 备注:
1. 自动机包装前先剪掉2格后调整前段空出10格, 中间装800PCS产品, 尾端也需空出10格;
 2. 按照图示方向将成品一一放入REEL包装盘内, 依同一方向放入;
 3. 一个REEL包装盘放置800个成品, 装满成品的REEL盘外圈需装上保护带, 四周贴上美纹胶, 盘面贴一张内标签;
 4. 将每盘产品依次放入箱内, 一箱装10盘(800*10=8000PCS). 四周用三角板固定, 最后用透明胶纸将纸箱四周封实, 箱外贴上外标签;
 5. 若有未装满之零数箱, 必须以缓行材料塞满, 数量比较少时可单盘包装出货;
 6. 剥离力0.1-1.3KG(300mm/min), 剥离角度:165°~180°;
 7. 适用产品:TYPE C 24PIN板上双排SMT

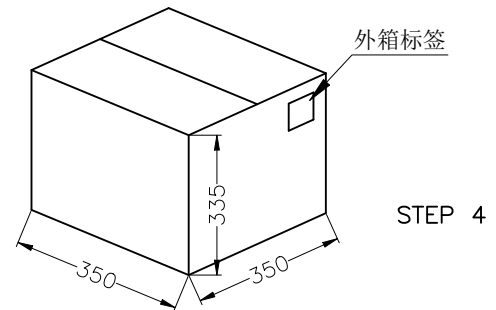
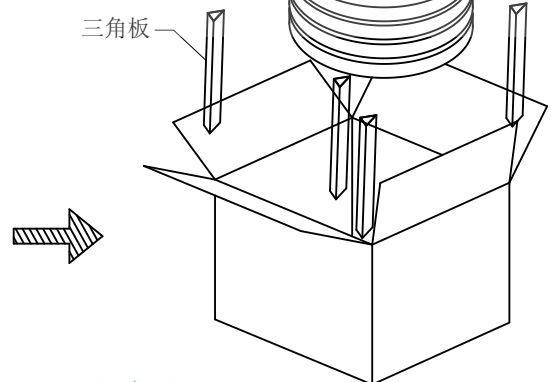
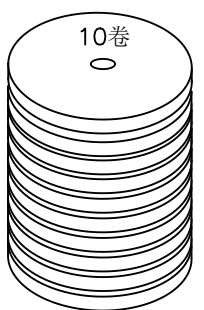
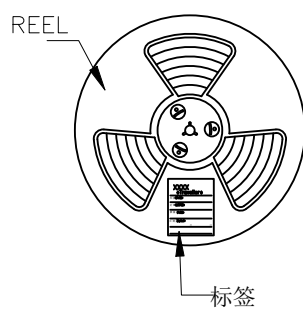
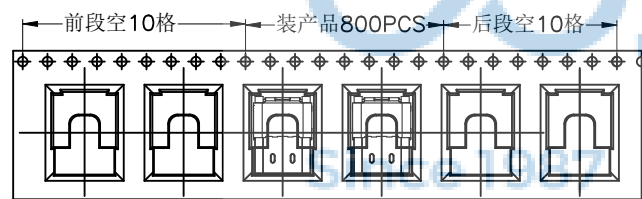

THIS DOCUMENT IS THE SOLE PROPERTY OF BBJconn Technology Co., Ltd. Corporation AND SHOULD NOT BE USED IN WHOLE OR IN PART WITHOUT PRIOR WRITTEN PERMISSION.		深圳市步步精科技有限公司 NAME: TYPE-C 24P 母座 双壳 板上四脚DIP 带柱 端子双排SMT L=12.4 CH=1.73 LCP黑胶 编带 APPD. JM_Zheng CHKD. LYX DR. SGF	
PDWG.NO: 0853-1	.X: ±0.38 .XX: ±0.25 .XXX: ±0.13	X': ±3' .X': ±2' .XX': ±1'	PJ. NO.: 126-221-240002-N4G SIZE: A4 FINISH: SEE NOTES SCALE: N/A REV.: A0 UNIT: mm PAGE: 2/2