

REV	ECN NO	CONTENT	DATE	ENGINEER
AO		INITIAL RELEASE	/	SGF

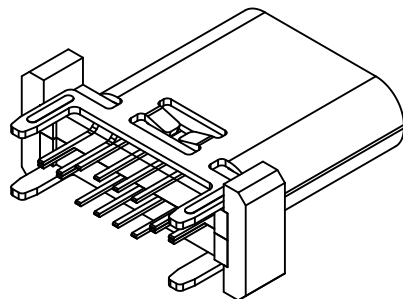

备注:

1. 材质:

1.1 胶芯: LCP+30%G. F UL94V-0

1.2 端子: C7025 ; 镀底50U" MIN

接触区域镀金 (AU 1u") 焊接区域镀

金G/F

1.3 外壳: SUS304, T=0.30mm: 表面镀镍  
30U" MIN

1.4 中夹片: SUS301:

2. 主要特性:

2.1 额定电流: 5A

2.2 接触阻抗: 40mΩ MAX (初始值)  
50mΩ MAX (测试后)

2.3 绝缘阻抗: 100MΩ MIN

2.4 耐压测试: 100V AC R M S

2.5 整体插入力: 5-20N 整体拔出力: 5-20N (耐久后)

整体拔出力: 8-20N 整体拔出力:

6-20N (耐久后)

2.6 耐久: 10000次

2.7 耐高温: SMT回流焊 (峰值260° ±5°),  
塑胶不能有起泡,

融胶等不良, 变色, 翘曲变形在公差范围  
以内。

2.8 产品须做焊锡测试, 粘锡面积达到95%以上:

2.9 盐雾测试: 24H MIN

3.0 工作温度: -25°C ~ +80°C

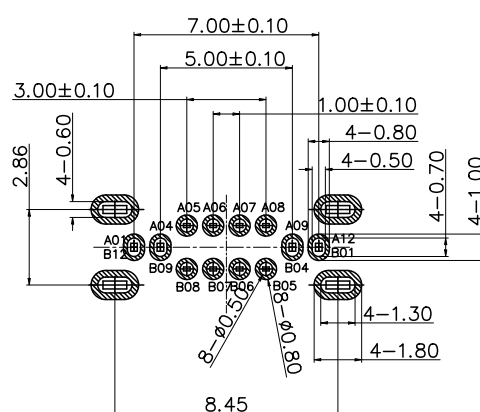
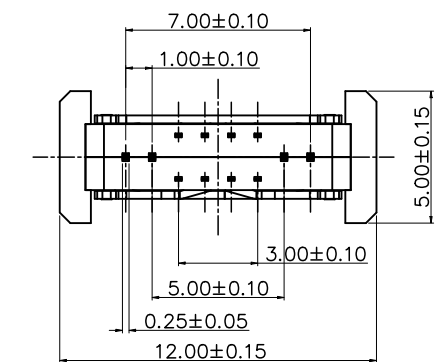
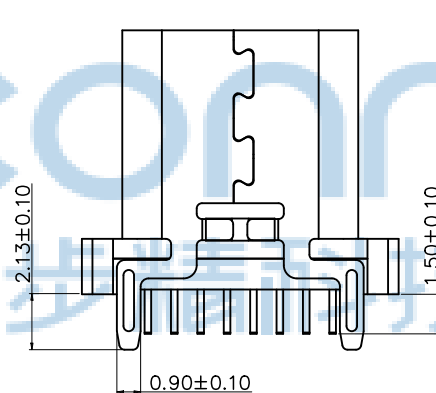
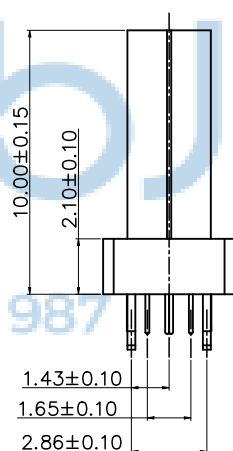
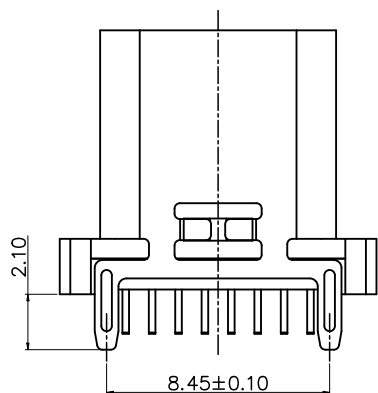
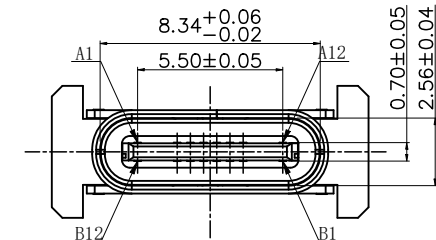

RECOMMENDED P.C.B. LAYOUT (俯视图)  
TOLERANCE UNSPECIFIED ±0.05mm



A1	GND	B12	GND
A4	VBUS	B9	VBUS
A5	CC1	B8	SBU2
A6	D+	B7	D-
A7	D-	B6	D+
A8	SBU1	B5	CC2
A9	VBUS	B4	VBUS
A12	GND	B1	GND
PIN	SIGNAL NAME	PIN	SIGNAL NAME

THIS DOCUMENT IS THE  
SOLE PROPERTY OF  
BBJconn Technology Co., Ltd.  
Corporation AND SHOULD  
NOT BE USED IN WHOLE  
PRIOR WRITTEN PERMISSION.

**深圳市步步精科技有限公司**

APPD	JM_Zheng	NAME: TYPE-C 16P 母座 直立式 四脚插 端子DIP H=10.0 带中夹片 LCP黑胶 不锈钢外壳 编带
CHKD	LYX	PJ NO: 126-225-160004-J8G SIZE: A4 DRW NO:
PDWG NO: 0242-2	DR	SGF FINISH: SEE NOTES SCALE: N/A REV: AO MAT'L: SEE NOTES UNIT: mm PAGE: 1/2

REV	ECN NO	CONTENT	DATE	ENGINEER
AO		INITIAL RELEASE	/	SGF

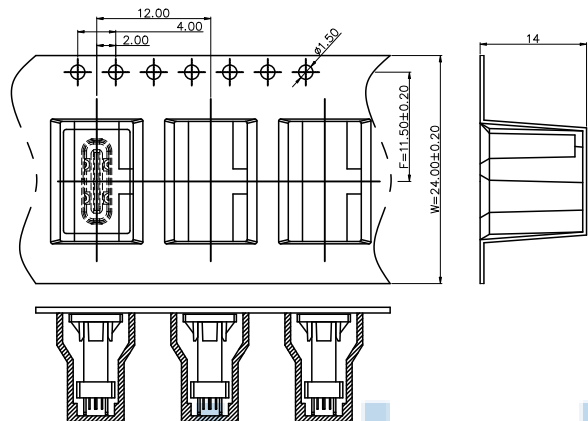

① 产品入载带示意图

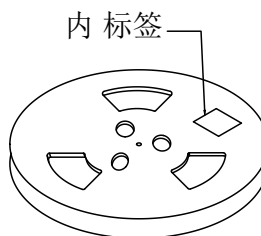

② 卷盘贴标签示意图

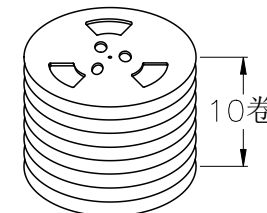

③ 10盘产品叠层示意图

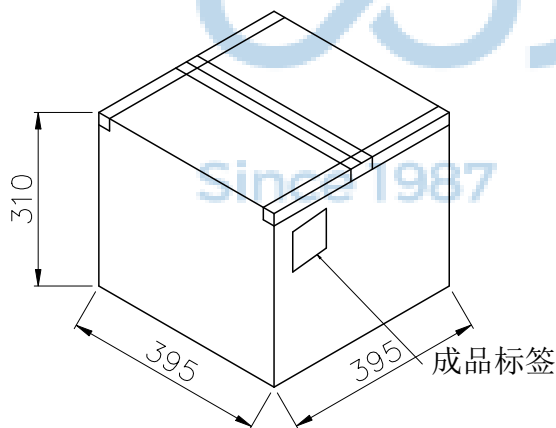

⑤ 外箱封箱示意图

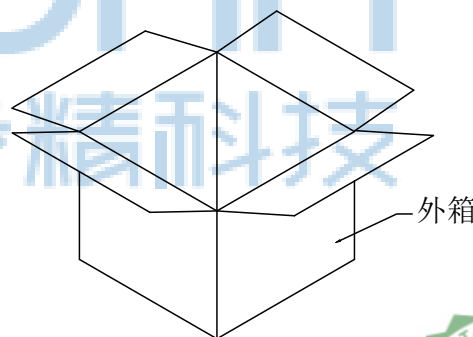

④ 产品入外箱示意图



包装说明:

1. 将检验好的成品;SMT朝下放入载带底部;每卷装500PCS产品;具体如图一所示
2. 将包装好的产品;每盘必需贴上内标签;具体如图二所示
3. 将贴好内标签的产品每10盘叠;具体如图三所示
4. 装好后并封好纸箱及贴好相关标签;具体如图五所示;
5. (产品包装的标签,如客户有要求,请按客户要求包装出货)
6. 载带前面留10PCS空格,后面留10PCS空格
7. COVER与CARRY剥离力:50-125g,速度:300mm/分钟左右,剥离角度:165° -180°

THIS DOCUMENT IS THE  
SOLE PROPERTY OF  
BBJconn Technology Co.,Ltd.  
Corporation AND SHOULD  
NOT BE USED IN WHOLE  
PRIOR WRITTEN PERMISSION.  
PDWG NO: 0242-2

深圳市步步精科技有限公司

.X: ±0.38 X': ±3'  
.XX: ±0.25 .X': ±2'  
.XXX: ±0.13 .XX': ±1'

NAME:TYPE-C 16P 母座 直立式 四脚插 端子DIP  
H=10.0 带中夹片 LCP黑胶 不锈钢外壳 编带

APPD JM\_Zheng  
CHKD LYX  
DR SGF

PJ NO: 126-225-160004-J8G  
SIZE:A4 DRW NO:  
FINISH:SEE NOTES MAT'L:SEE NOTES  
SCALE:N/A REV:AO UNIT:mm PAGE:2/2