

P.C.B LAYOUT (Component Side)
P.C.B Thickness=X.Xmm(Tolerance=±0.05)

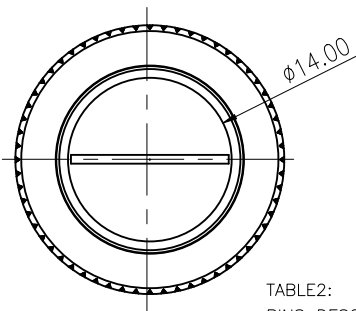

- 技术参数:
- TYPE-C 公头 24P
 - 塑胶材质:LCP UL94V-0;
 - 端子材质:黄铜;
接触区域:镀镍50u"Min/锡100u"Min;
其他区域:镀锡50u"Min;
 - 外壳:SUS316L, T=0.15mm;
 - 额定电流:5A MAX;
 - 额定电压:20V DC MAX;
 - 耐电压:100V AC;
 - 接触电阻:40mΩ MAX;
 - 绝缘电阻:100MΩ MAX;
 - 使用温度: -30° C~+80° C.
 - 寿命: 10000次;
 - 初始插入力:5~20N;
 - 初始拔出力:8~20N;
 - 五金件
 - 材质:SUS和黄铜;
 - 防水圈
 - 材质: 硅胶;
 - 防水等级: IPX7.

TABLE2:
PINS DESCRIPTION,ONLY USED FOR 3.1 SERIES.

A12	A11	A10	A9	A8	A7	A6	A5	A4	A3	A2	A1
GND	RX2+	RX2-	VBUS	SBU1	D-	D+	CC	VBUS	TX1-	TX1+	GND
GND	TX2+	TX2-	VBUS	Vconn			SBU2	VBUS	RX1-	RX1+	GND
B1	B2	B3	B4	B5	B6	B7	B8	B9	B10	B11	B12

THIS DOCUMENT IS THE SOLE PROPERTY OF BBJconn Technology Co.,Ltd. Corporation AND SHOULD NOT BE USED IN WHOLE PRIOR WRITTEN PERMISSION.	深圳市步步精科技有限公司	
	.X: ±0.38 .XX: ±0.25 .XXX: ±0.13	X': ±3' .X': ±2' .XX': ±1'
APPD	JM_Zheng	NAME: TYPE-C 公头 24P IPX7
CHKD	LYX	PJ NO: 170-109-240001-00G SIZE:A4 DRW NO:
PDWG NO:9999-9	DR GZY	FINISH:SEE NOTES SCALE:N/A REV:A0 UNIT:mm MAT'L:SEE NOTES PAGE:1/1