

REV.	ECN NO	CONTENT	DATE	ENGINEER
A0		Initial release	/	TSP

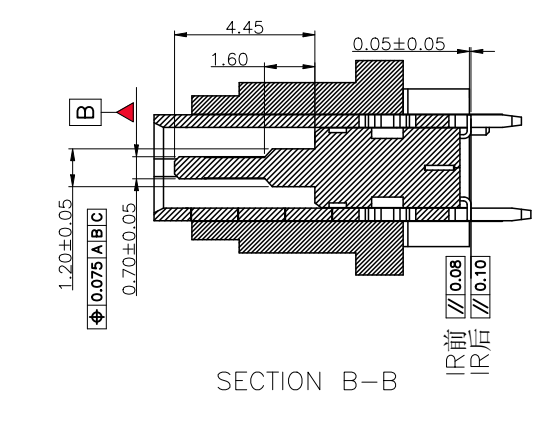

NOTE:
1.MATERIAL:
1.1 INSULATOR: HIGH TEMPERATURE PLASTIC UL 94 V-0; Black Color
1.2 CONTACT: C7025(T=0.12mm)
1.3 SHELL:STAINLESS STEEL(T=0.30mm)
1.4 INNER GROUND COVER SHELL:STAINLESS STEEL(T=0.10mm)
1.5 MID PLATE:STAINLESS STEEL(T=0.15mm)
2.ELECTRICAL CHARACTERISTICS;
2.1 CONTACT RESISTANCE: 40mΩ Max FOR INITIAL, 10mΩ CHANGE AFTER TEST. MEASURE AT 20mV, 100mA.
2.2 CONTACT CURRENT RATING: 5A FOR COLLECTIVELY POWER SUPPLY PINK(PINA1,A4,A9,A12,B1,B4,B9,B12); 1.25A FOR VCONN PIN; 0.25A FOR OTHER SIGNAL PIN.
2.3 DIELECTRIC WITHSTANDING VOLTAGE: 100V AC R.M.S.
2.4 INSULATION RESISTANCE 100MΩ Min
2.5 OPERATING TEMPERATURE: -40°C ~ 85°C
3 MECHANICAL CHARACTERISTICS:
3.1 MATING FORCE: 5~20 N.
3.2 UNMATED FORCE: 8~20N INITIAL TEST; 6~20N DURABILITY AFTER TEST
3.3 DURABILITY: 10,000 CYCLES
4.PLATING
4.1 TERMINAL CONTACT: Au 3u" PLATING ON CONTACT AREA; TIN 50u" Min TING ON SOLDER TAIL,NI 50u" Min UNDERPLATING OVERALL
4.2 SHELL: 50u" Min. NICKEL ALL OVER,
4.3 MID PLATE: CLEAN

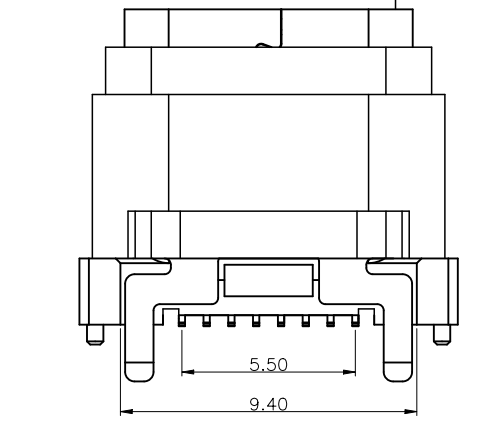
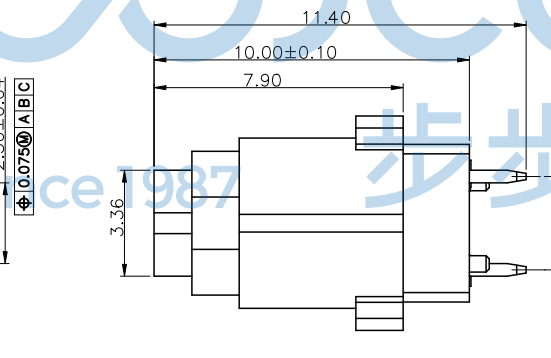
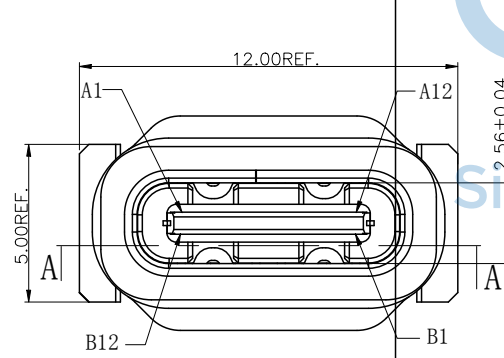
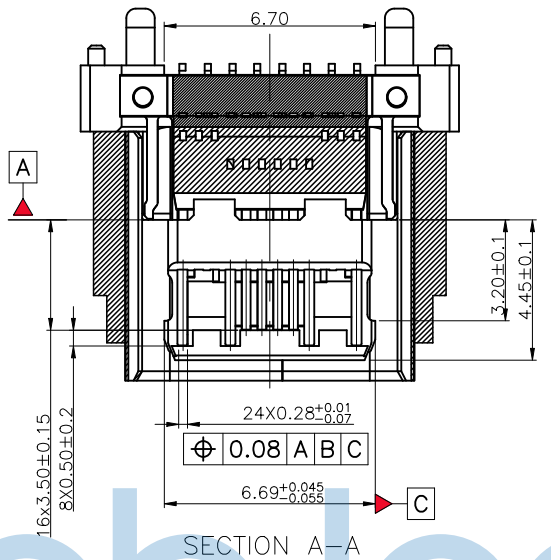
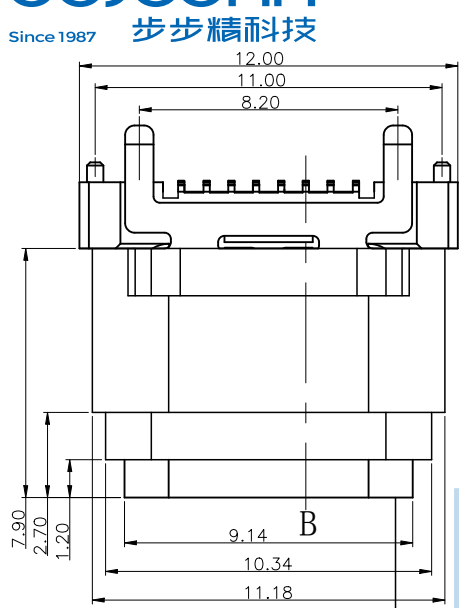
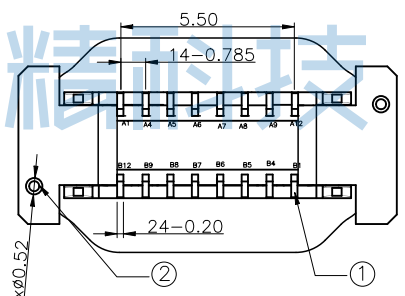
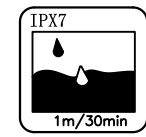

NO.	DESCRIPTION	MATERIAL	REMARKS	QTY	盐雾	PACKAGING
5	CAP	LCP 6007AS UL94V-0	BLACK	1PCS		
4	SHELL	SUS304 T=0.40mm	Ni 50u" Min Plated	1PCS		
3	LATCH	SUS301-H T=0.15mm	NO PLATED	1PCS	48H	Reel
2	CONTACT	C7025 T=0.12mm	Au 3u" PLATING ON CONTACT AREA, TIN 50u" Min TING ON SOLDER TAIL, NI 50u" Min UNDERPLATING OVERALL	1SET		
1	HOUSING	LCP UL94V-0	LCP BLACK UL94V-0	1PCS		

THIS DOCUMENT IS THE SOLE PROPERTY OF BBJconn Technology Co.,Ltd. Corporation AND SHOULD NOT BE USED IN WHOLE OR IN PART WITHOUT PRIOR WRITTEN PERMISSION. PDWG.NO: 0395-1

深圳市步步精科技有限公司

NAME: TYPE-C 16P 防水母座 直立式加宽 四脚插 带柱 端子SMT H=10.0 IPX7 镀金3U 编带

APPD. JM_Zheng
CHKD. LYX
DR. TSP

PJ. NO.: 126-224-160003-J2G
SIZE: A4 DRW NO.:
FINISH: SEE NOTES MAT'L.: SEE NOTES
SCALE: N/A REV.: A0 UNIT: mm PAGE: 1/4

REV.	ECN NO.	CONTENT	DATE	ENGINEER
A0		Initial release	/	TSP

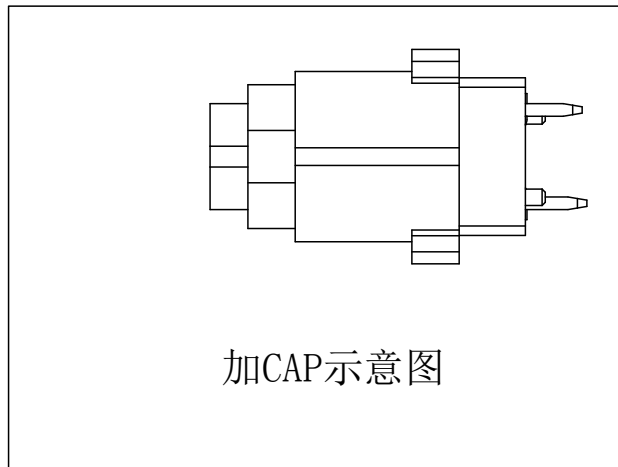
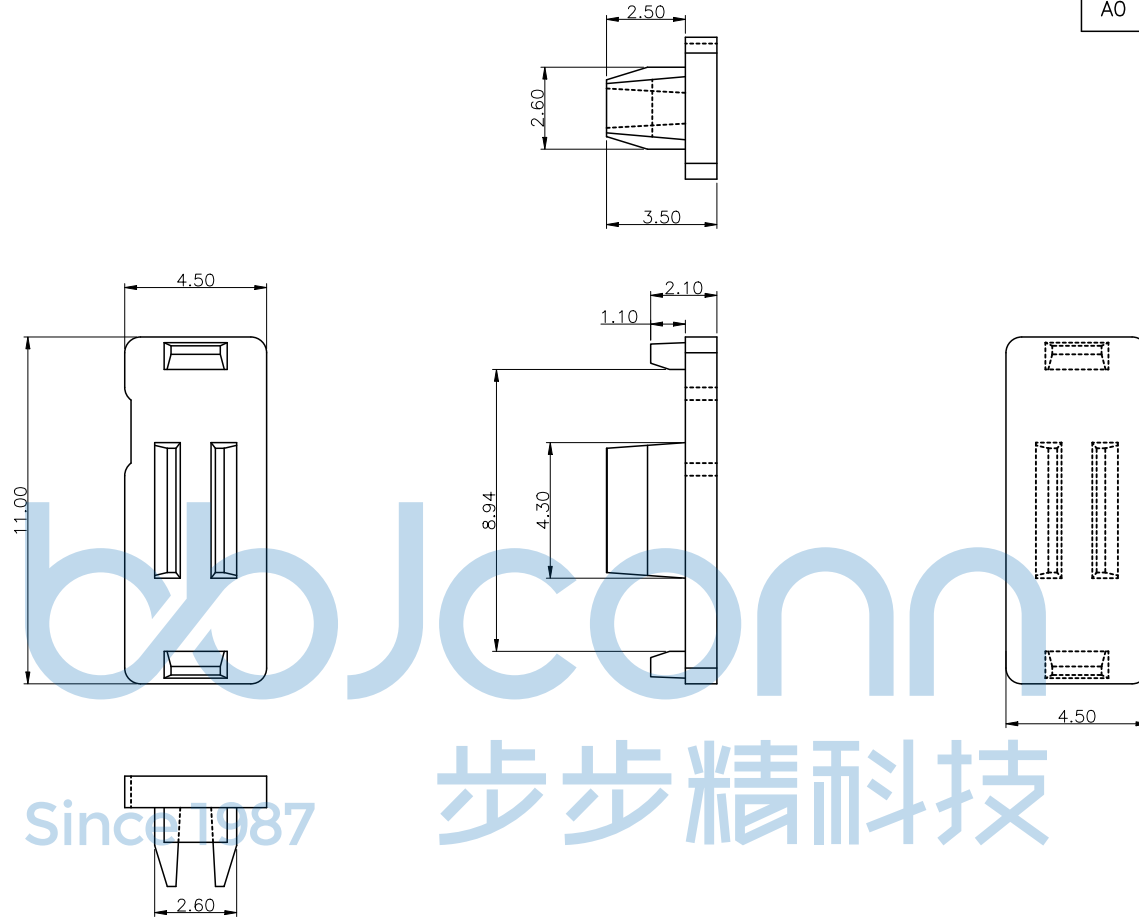

加CAP示意图

THIS DOCUMENT IS THE SOLE PROPERTY OF BBJconn Technology Co.,Ltd. Corporation AND SHOULD NOT BE USED IN WHOLE OR IN PART WITHOUT PRIOR WRITTEN PERMISSION.		深圳市步步精科技有限公司	
.X: ±0.38 .XX: ±0.25 .XXX: ±0.13 X': ±3" X'': ±2" XX': ±1"		NAME: TYPE-C 16P 防水母座 直立式加宽 四脚插带柱 端子SMT H=10.0 IPX7 镀金3U 编带	
APPD.	JM_Zheng	PJ. NO.: 126-224-160003-J2G SIZE: A4 DRW NO.:	FINISH: SEE NOTES MAT'L.: SEE NOTES SCALE: N/A REV.: A0 UNIT: mm PAGE: 2/4
CHKD.	LYX		
PDWG.NO:	0395-1	DR.	TSP

USB TYPE-C FULL-FEATURED RECEPTACLE INTERFACE PIN ASSIGNMENTS

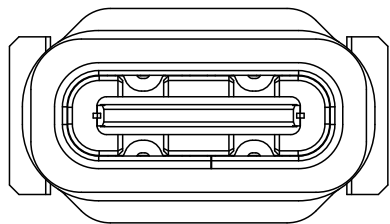

加防水圈示意图

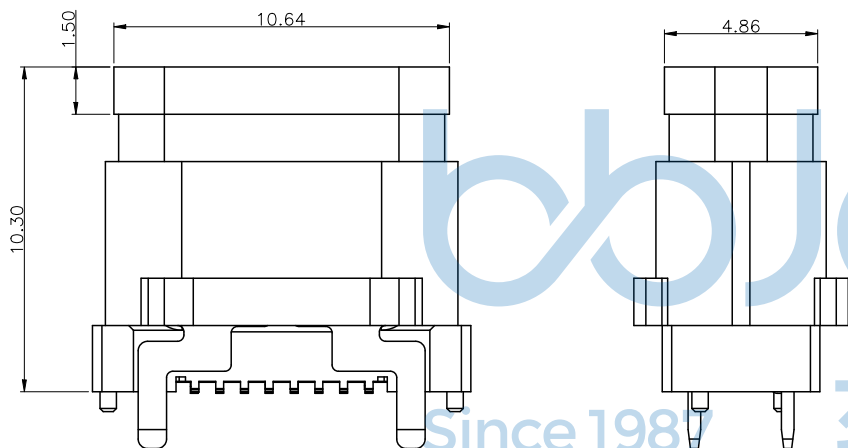

PIN	Signal Name	Description	PIN	Signal Name	Description
A1	GND	Ground return	B12	GND	Ground return
A4	VBUS	Bus Power	B9	VBUS	Bus Power
A5	CC1	Configuration Channel	B8	SBU2	Sideband Use (SBU)
A6	Dp1	Positive half of the USB 2.0 differential pair-Position 1	B7	Dn2	Negative half of the USB 2.0 differential pair-Position 2
A7	Dn1	Negative half of the USB 2.0 differential pair-Position 1	B6	Dp2	Positive half of the USB 2.0 differential pair-Position 2
A8	SBU1	Sideband Use (SBU)	B5	CC2	Configuration Channel
A9	VBUS	Bus Power	B4	VBUS	Bus Power
A12	GND	Ground return	B1	GND	Ground return

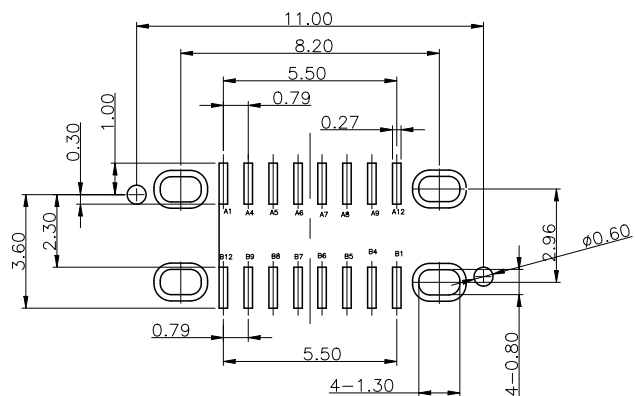

RECOMMENDED P.C.B. LAYOUT (T:1.00mm)
TOLERANCE UNSPECIFIED ±0.05mm



THIS DOCUMENT IS THE SOLE PROPERTY OF BBJconn Technology Co., Ltd. Corporation AND SHOULD NOT BE USED IN WHOLE OR IN PART WITHOUT PRIOR WRITTEN PERMISSION.		深圳市步步精科技有限公司 .X: ±0.38 .XX: ±0.25 .XXX: ±0.13 X': ±3" .X': ±2" .XX': ±1"		NAME: TYPE-C 16P 防水母座 直立式加宽 四脚插带柱 端子SMT H=10.0 IPX7 镀金3U 编带 APPD. JM_Zheng CHKD. LYX DR. TSP	
PDWG.NO: 0395-1		PJ. NO.: 126-224-160003-J2G SIZE: A4 DRW NO.: FINISH: SEE NOTES MAT'L.: SEE NOTES SCALE: N/A REV.: A0 UNIT: mm PAGE: 3/4			

REV.	ECN NO.	CONTENT	DATE	ENGINEER
A0		Initial release	/	TSP

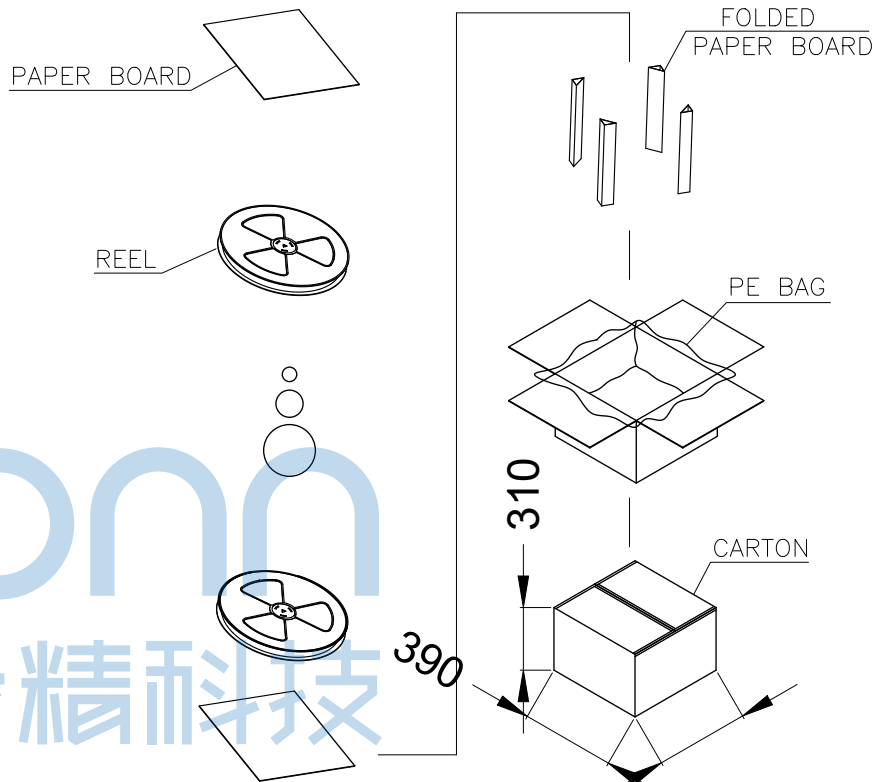
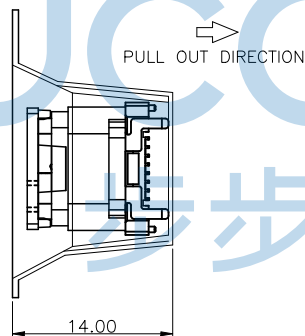
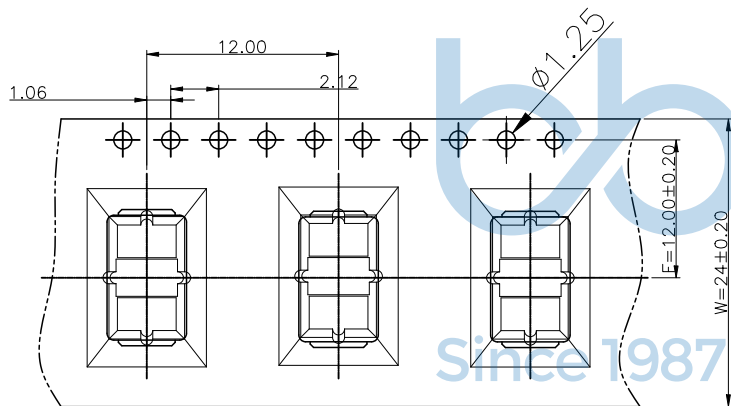
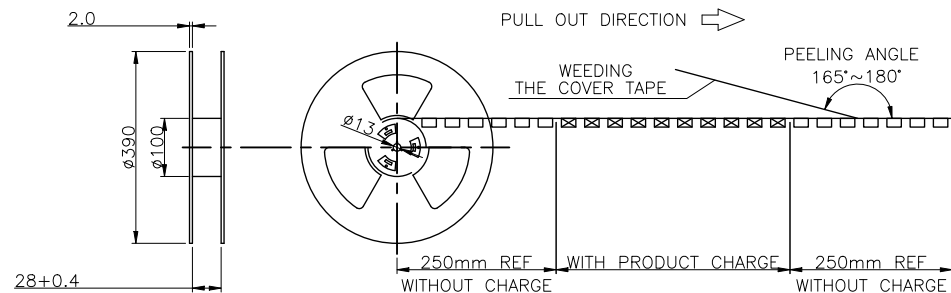

NOTE:
1. QUANTITY: 450 PCS/REEL, 4500PCS/CARTON.

注意:

1. 材料:

纸箱: 纤维板, 瓦楞, 双层壁。

胶带: 聚苯乙烯, 耐热温度: 120℃, 白。

卷筒: 聚苯乙烯, 耐热温度: 70℃, 蓝色。

包装: 聚乙烯, 耐热温度: 100℃。

2. 剥离强度: 0.1 ~ 1.3 N(10 ~ 130克)

3. 脱皮速度: 300mm /min。

4. 每个袋子都应包括干燥剂*2。

5. 外箱上贴号物料标签及RHOS标签

6. 同一产品只能装同一纸箱, 不允其它产品;

7. 包装后, 产品铆合面朝外; 柱子朝内;



600	10	6000 PCS
PCS/卷	卷/箱	箱

THIS DOCUMENT IS THE SOLE PROPERTY OF BBJconn Technology Co., Ltd. Corporation AND SHOULD NOT BE USED IN WHOLE OR IN PART WITHOUT PRIOR WRITTEN PERMISSION.		PDWG. NO: 0395-1		DR. TSP		深 圳 市 步 步 精 科 技 有 限 公 司	
.X: ±0.38		.XX: ±0.25		.XXX: ±0.13		NAME: TYPE-C 16P 防水母座 直立式加宽 四脚插带柱 端子SMT H=10.0 IPX7 镀金3U 编带	
.X': ±3"		.X'': ±2"		.X'': ±1"		PJ. NO.: 126-224-160003-J2G	
APPD. JM_Zheng		CHKD. LYX		DR. TSP		SIZE: A4 DRW NO.:	
FINISH: SEE NOTES		SCALE: N/A		REV.: A0		MAT'L.: SEE NOTES	
UNIT: mm		PAGE: 4/4					