

REV.	ECN NO	CONTENT	DATE	ENGINEER
A0		Initial release	/	TSP

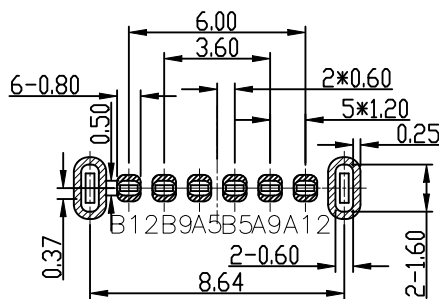

备注 (NOTE):

- 电气特性:
  - 接触区: 接触电阻40mΩ Max, 允许10mΩ变化量. 测试条件: 20mv, 100mA下测量.
  - 接触电流: 3A VBUS引脚; 1.25A用于GND引脚; 其他引脚为0.25A.
  - 额定电压: 5V.
  - 耐电压: 500 V(AC) for 1 min.
  - 绝缘电阻: 至少100兆欧.
- 机械性能:
  - 插入力: 5-20N
  - 拔出力: 6-20N
  - 插拔次数: 10000次.
  - 推力: 50N min.
  - 剥离强度: 150N min.
  - 扭曲强度: 0.75Nm
- 工作环境: -20℃ to +85℃.
- 尺寸标注事项:
  - 图示有标注“▲”记号者为重点尺寸.  
首件检验尺寸为⑩到⑬;  
巡检尺寸为⑭, ⑮至⑰.
  - 图示所有标注“Cpk”尺寸为Cpk检验尺寸.
  - 图示未标注公差之尺寸参考公差表.
  - 图示标注“\*”记号之尺寸为对称尺寸.
- 材料:
  - 塑胶: PA9T 黑色UL94V-0 无卤
  - 端子: C2680镀半金雾锡1U”
  - 壳子: SUS201-1/2H 镀镍24H

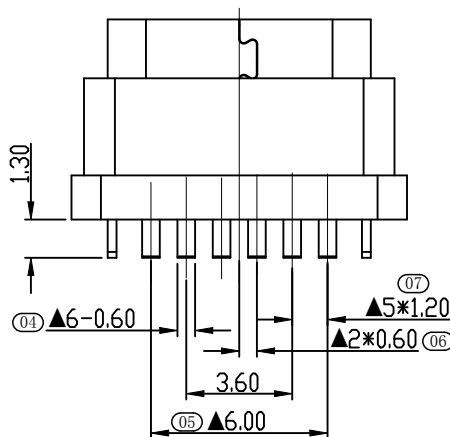
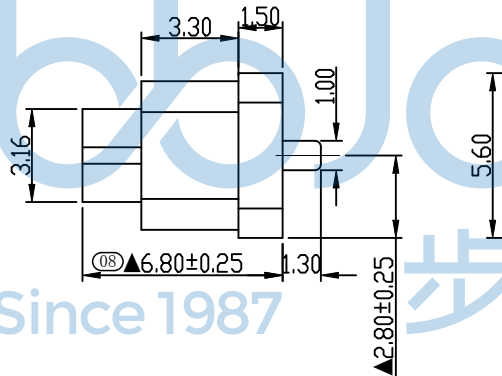
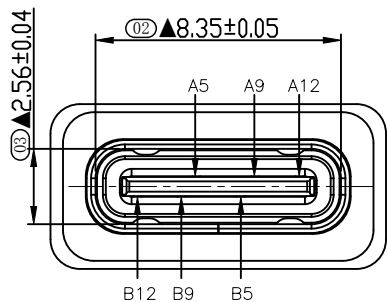
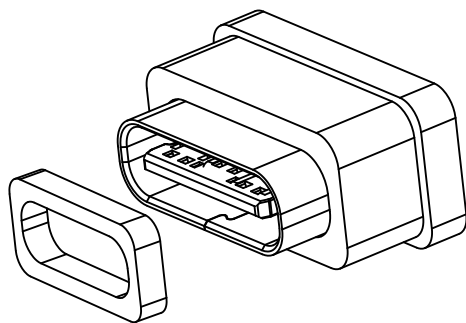
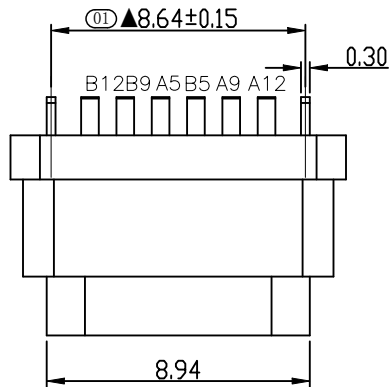
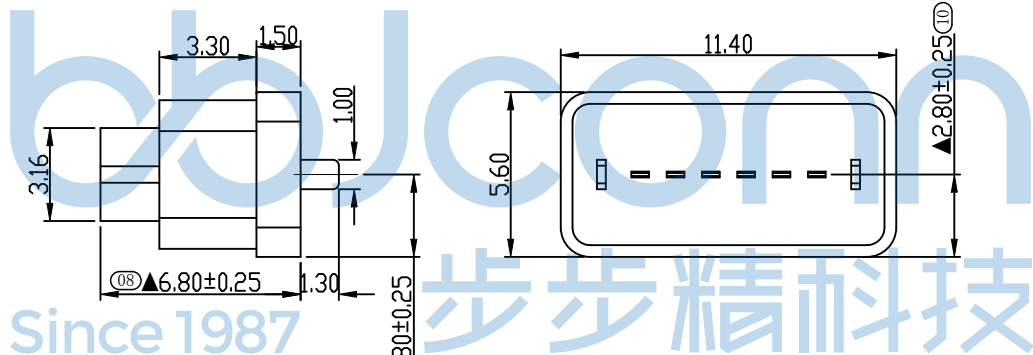

PCB板参考图

密封圈

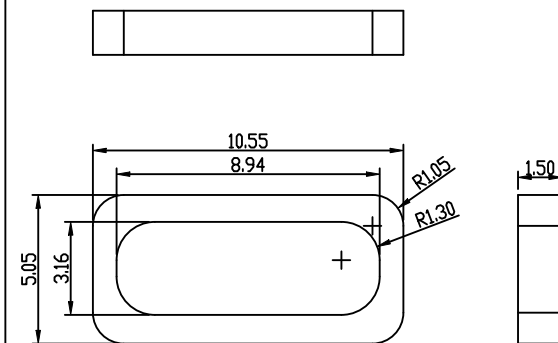

A12	A11	A10	A9	A8	A7	A6	A5	A4	A3	A2	A1
GND			VBUS				CC1				
				CC1				VBUS			GND
B1	B2	B3	B4	B5	B6	B7	B8	B9	B10	B11	B12

THIS DOCUMENT IS THE SOLE PROPERTY OF BBJconn Technology Co., Ltd. Corporation AND SHOULD NOT BE USED IN WHOLE OR IN PART WITHOUT PRIOR WRITTEN PERMISSION. PDWG.NO: 0395-1

APPD.		CHKD.		DR.	
JM_Zheng	LYX	TSP			

深圳市步步精科技有限公司

NAME: TYPE-C 6P 防水母座 直立式 两脚插 H=6.80 铆合壳盲插 充电版带OTG 端子DIP 带中夹片 IPX8

PJ. NO.: UC.01.63-1J-0003

SIZE: A4 DRW NO.:

FINISH: SEE NOTES MAT'L.: SEE NOTES

SCALE: N/A REV.: A0 UNIT: mm PAGE: 1/2

REV.	ECN NO	CONTENT	DATE	ENGINEER
A0		Initial release	/	TSP

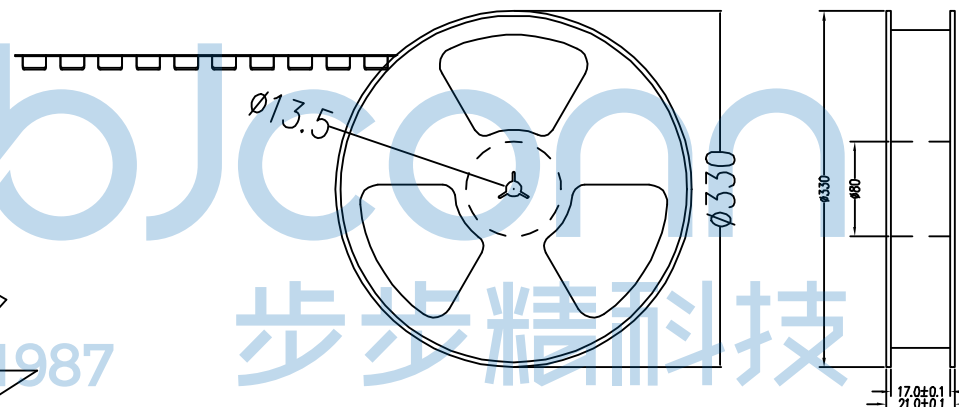
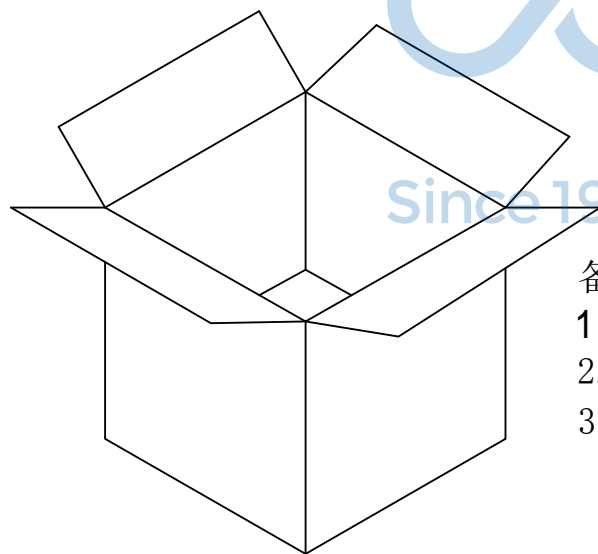
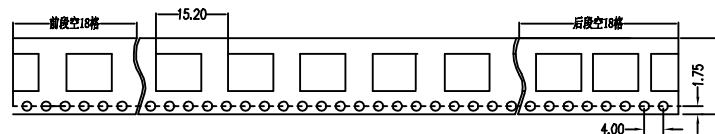
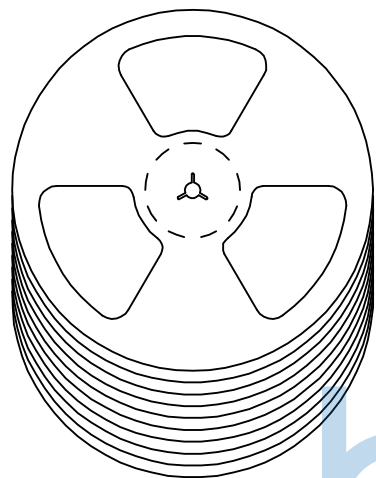

备注:

1. 包装数量：600/PCS/卷，10卷/箱
2. 包装袋长度：每卷前后各空10-20个空格，中间包装。
3. 材质：  
载体：聚丙烯（PS），  
上带：聚乙烯（PET），  
卷盘：聚苯乙烯。

纸箱规格：345\*345\*23MM

纸箱规格：345\*345\*35MM

THIS DOCUMENT IS THE SOLE PROPERTY OF BBJconn Technology Co.,Ltd. Corporation AND SHOULD NOT BE USED IN WHOLE OR IN PART WITHOUT PRIOR WRITTEN PERMISSION.		深圳市步步精科技有限公司 .X: ±0.38    .X': ±3' .XX: ±0.25    .X'': ±2' .XXX: ±0.13    .X''': ±1'		NAME: TYPE-C 6P 防水母座 直立式 两脚插 H=6.80 铆合壳盲插 充电版带OTG 端子DIP 带中夹片 IPX8	
APPD.	JM_Zheng	PJ. NO.: UC.01.63-1J-0003 SIZE: A4   DRW NO.:		FINISH: SEE NOTES   MAT'L.: SEE NOTES	
CHKD.	LYX	DR.		TSP	SCALE: N/A   REV.: A0   UNIT: mm   PAGE: 2/2
PDWG.NO:	0395-1				