

RECOMMENDED PCB LAYOUT  
(Tolerance=±0.05)

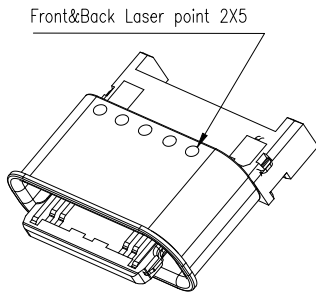
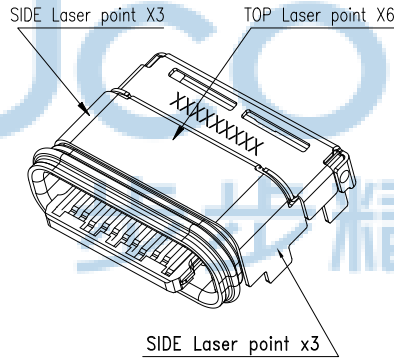
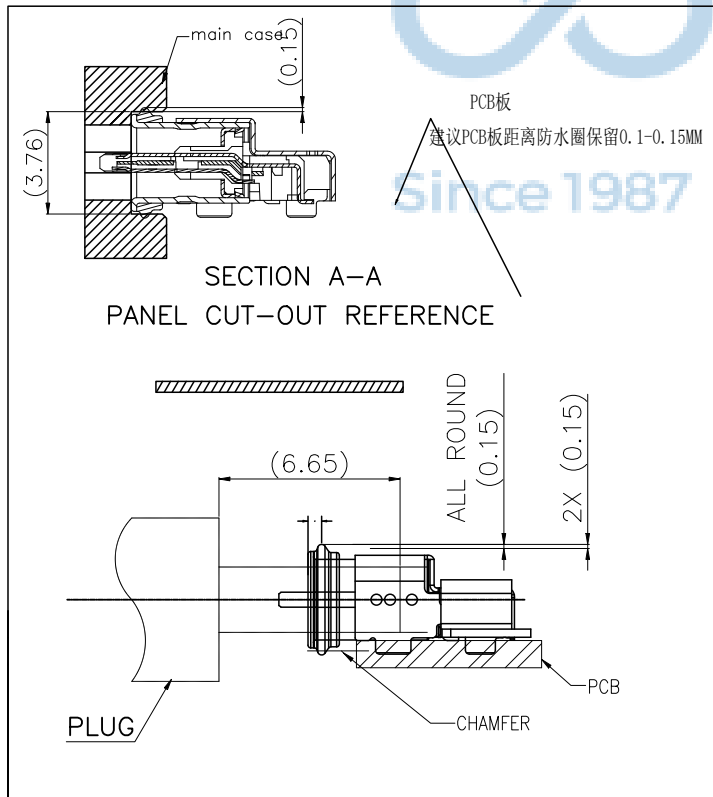

说明:

- Colplanarity: 0.08最大红外线前., 0.10mm MAX
- 舌PIN的位置: IR前: 0.08mm MAX; IR后0.12mm MAX;
- P/N:
- 包装方式: 载带包装
- 接触区和焊接区无毛刺, 除特说明, 冲压毛刺为0.05mm MAX.
- 未标注尺寸公差为自由公差为准.
- 成品端子平面度必须100%检测.
- 成品可靠性测试要求参照规格书.
- 产品满足 ROHS 2.0

项目	组成部件	用量	材质/处理	备注
9	密封圈	1PCS	硅胶, 黑色	
8	胶水	1PCS	环氧树脂, 黑色	
7	外壳	1PCS	SUS304, T=0.15. 镀镍50u" MIN.	
6	内拉伸壳	1PCS	SUS304, T=0.20.	
5	EMI拉伸壳	1PCS	SUS304, T=0.12. 镀镍50u" MIN.	
4	上排端子	1SET	C18400, T=0.12. 底层镀镍 50-100u", 功能接触区单面	
3	下排端子	1SET	刷镀 Au 30u", 焊接区双面镀金 G/F.	
2	中板	1PCS	SUS301-1/4 H, 镀镍50u" MIN.	
1	塑胶	1PCS	PA46 BLACK	

THIS DOCUMENT IS THE SOLE PROPERTY OF BBJconn Technology Co.,Ltd. Corporation AND SHOULD NOT BE USED IN WHOLE PRIOR WRITTEN PERMISSION.

PDWG NO: 0395-1

深圳市步步精科技有限公司

NAME:TYPE-C 24P 防水母座 板上四脚插 L=7.49 CH=1.5 舌片外漏1.15 端子双排SMT IPX8 镀金30U 编带

APPD: JM\_Zheng

CHKD: LYX

DR: SGF

PJ NO: 126-221-240002-J2G

SIZE:A4 DRW NO:

FINISH:SEE NOTES MAT'L:SEE NOTES

SCALE:N/A REV:AO UNIT:mm PAGE:2/3

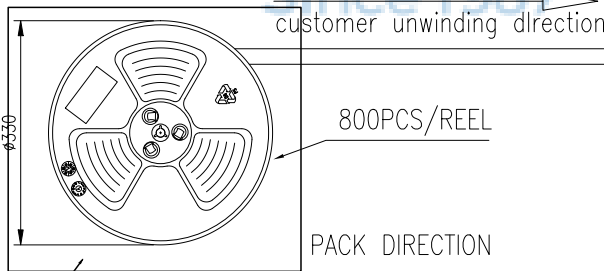
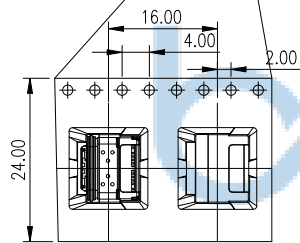
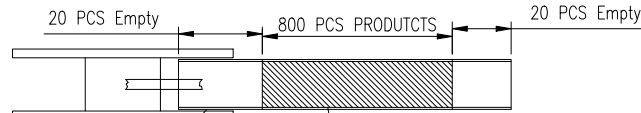

每盘真空包装+干燥剂



	REEL	CARTON
CONNECTOR (PCS)	800	8800

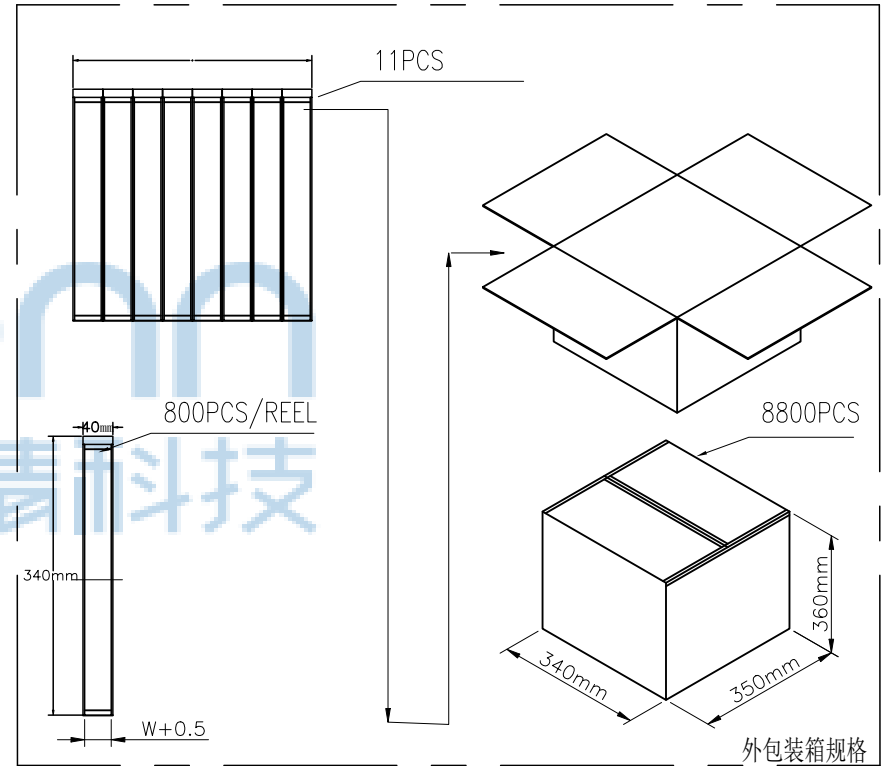

THIS DOCUMENT IS THE  
SOLE PROPERTY OF  
BBJconn Technology Co.,Ltd.  
Corporation AND SHOULD  
NOT BE USED IN WHOLE  
PRIOR WRITTEN PERMISSION.  
PDWG NO: 0395-1

**深圳市步步精科技有限公司**

.X: ±0.38	X': ±3'	NAME:TYPE-C 24P 防水母座 板上四脚插 L=7.49 CH=1.5 舌片外漏1.15 端子双排SMT IPX8 镀金30U 编带
.XX: ±0.25	.X': ±2'	
.XXX: ±0.13	.XX': ±1'	
APPD	JM_Zheng	PJ NO: 126-221-240002-J2G
CHKD	LYX	SIZE:A4   DRW NO:
DR	SGF	FINISH:SEE NOTES   MAT'L:SEE NOTES
		SCALE:N/A   REV:A0   UNIT:mm   PAGE:3/3