

REV	ECN NO	CONTENT	DATE	ENGINEER
A0		INITIAL RELEASE	/	SGF

Note:

1. Material:

- 1.1 InsertMolding: PA9T UL 94V-0 Black
- 1.2 Contact:C7025, t=0.12mm contact area 1U" welding area g/f 中夹片 susT=0.15mm
- 1.3 Shell: Zinc Alloy. 表面镀镍50 MIN
- 1.4 Waterproof ring:red silicone

2. ELECTRICAL:

- 2-1:CURRENT RATING:
VBUS AND GND CONTACTS RATED AT 1.25A PARALLELED FOR A TOTAL OF 5A;
- 2-2:INITIAL CONTACT RESISTANCE :40 MEGOHMS
- 2-3:DIELECTRIC WITHSTANDING VOLTAGE:
30V AC MIN;

3:MECHANICAL CHARACTERISTICS:

- 3-1:MATING FORCE:5~20N
- 3-2:UNMATING FORCE:8~20N(INITIAL),
6~20N(AFTER 10000 CYCLES)
- 3-3:FREQUENCY: 200±50 CYCLES /HOUR, 10000 CYCLES
- 3-4:OPERATING TEMPERATURE ;-40° ~80° .
- 4: WATERPROOF: IP-X7.

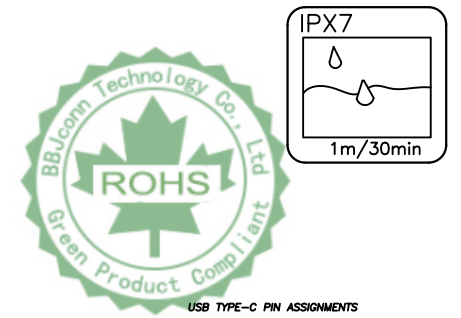
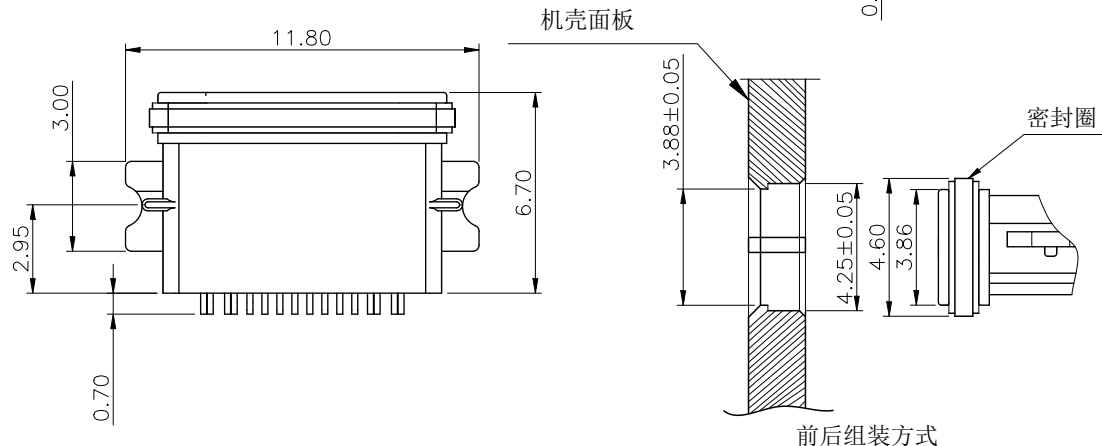
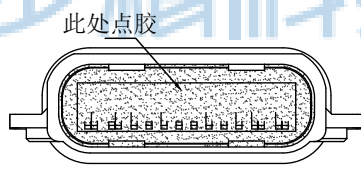
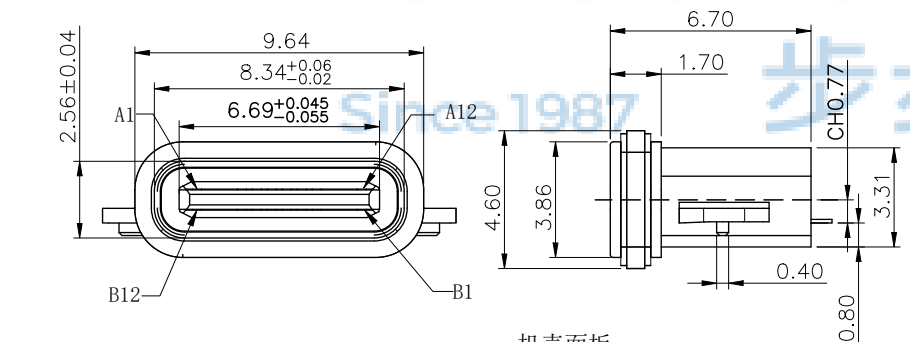
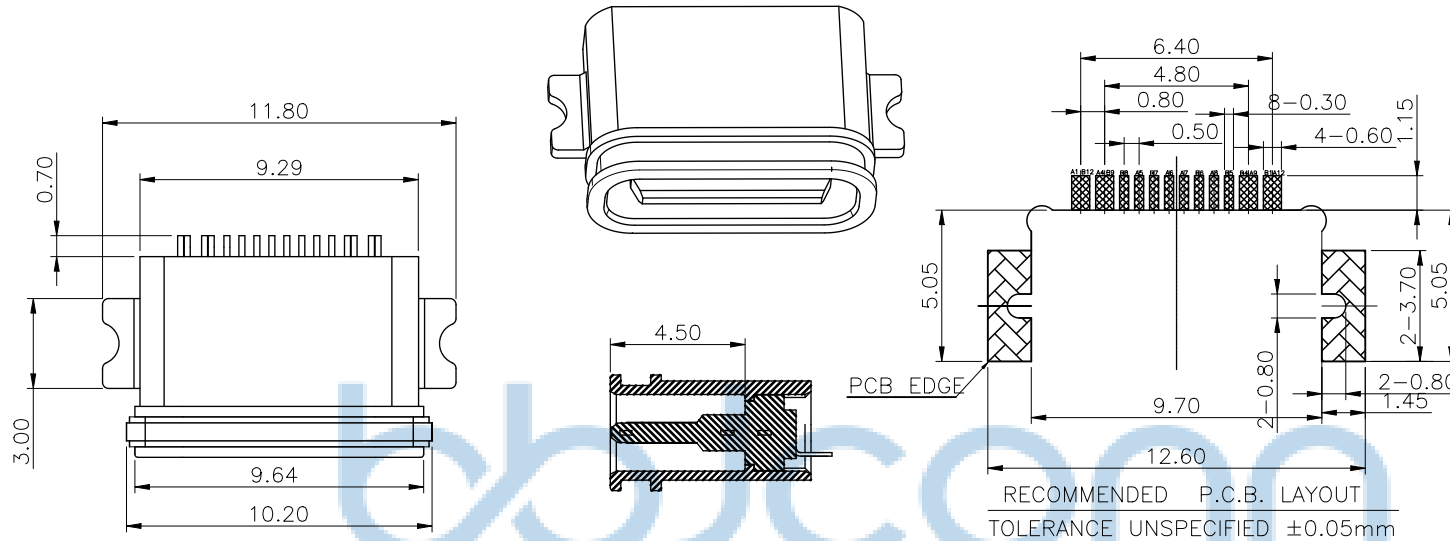

USB TYPE-C PIN ASSIGNMENTS

A1	GND	B12	GND
A4	VBUS	B9	VBUS
A5	CC1	B8	SBU2
A6	DP1	B7	DN2
A7	DN1	B6	DP2
A8	SBU1	B5	CC2
A9	VBUS	B4	VBUS
A12	GND	B1	GND
PIN	SIGNAL NAME	PIN	SIGNAL NAME

THIS DOCUMENT IS THE SOLE PROPERTY OF BBJconn Technology Co.,Ltd. Corporation AND SHOULD NOT BE USED IN WHOLE PRIOR WRITTEN PERMISSION.

深圳市步步精科技有限公司
工程管理部

NAME: TYPE-C 16P 防水母座 两脚贴 端子SMT 沉板0.8 带中夹片 L=6.7 CH=0.77 锌合金外壳 PA9T黑胶 红色防水圈 IPX7 编带

APPD: JM_Zheng
CHKD: LYX
DR: SGF

PJ NO: 126-221-160009-N5G
SIZE:A4
FINISH:SEE NOTES
SCALE:N/A

REV:AO
UNIT:mm
PAGE:1/2

REV	ECN NO	CONTENT	DATE	ENGINEER
A0		INITIAL RELEASE	/	SGF

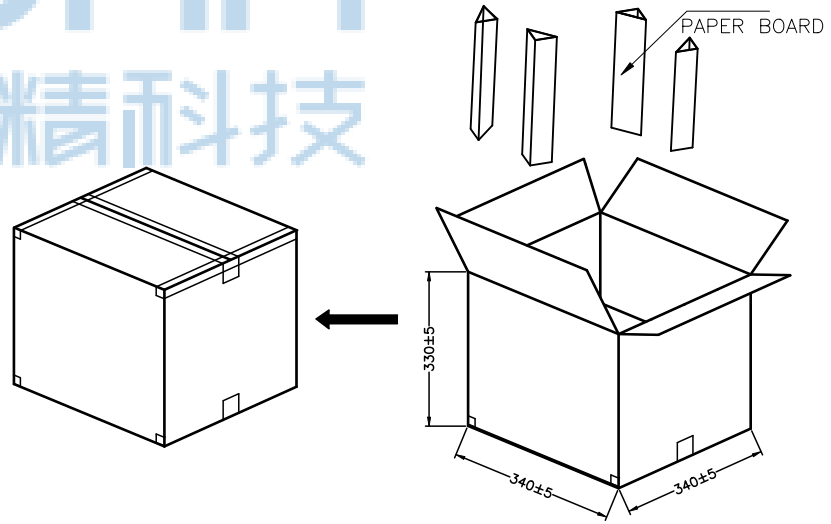
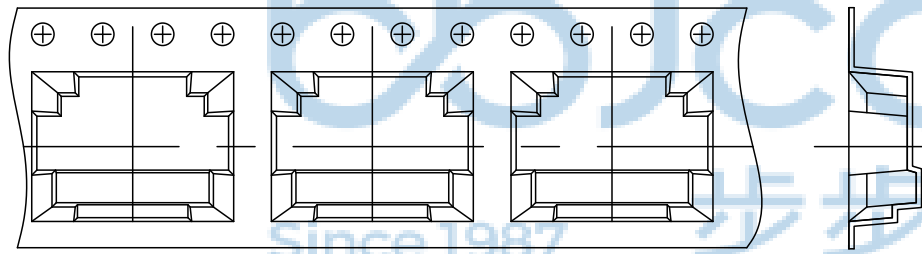
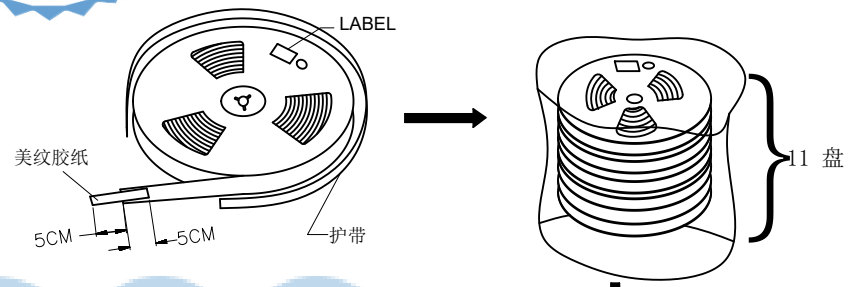
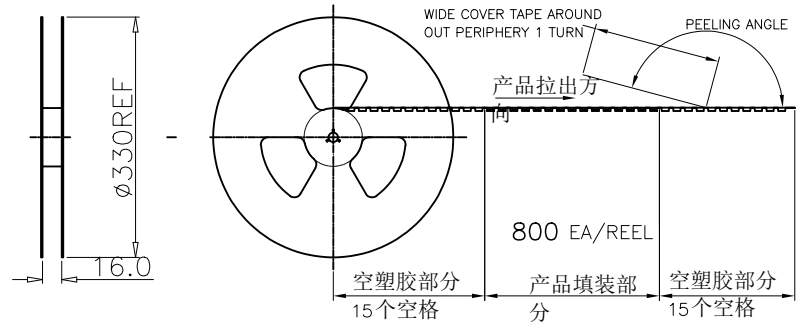

- 说明:1,将检查合格的产品,放入承载带中,一盘包装800PCS;
2,将11承载带放入纸箱中;
3,将纸箱封装好,贴上标签.

每箱数量	净重 (Kg)	毛重 (Kg)
8800PCS	XXX	XXX

THIS DOCUMENT IS THE SOLE PROPERTY OF BBJconn Technology Co.,Ltd. Corporation AND SHOULD NOT BE USED IN WHOLE PRIOR WRITTEN PERMISSION.		深圳市步步精科技有限公司	
PDWG NO: 0366-2		NAME: TYPE-C 16P 防水母座 两脚贴 端子SMT 沉板0.8 带中夹片 L=6.7 CH=0.77 锌合金外壳 PA9T黑胶 红色防水圈 IPX7 编带	
APPD	JM_Zheng	PJ NO:	126-221-160009-N5G
CHKD	LYX	SIZE:A4	DRW NO:
DR	SGF	FINISH:SEE NOTES	MAT'L:SEE NOTES
		SCALE:N/A	REV:A0 UNIT:mm PAGE:2/2