

REV	ECN NO	CONTENT	DATE	ENGINEER
A0		INITIAL RELEASE	/	SGF

NOTE:

1.MATERIAL SPECIFICATION:

- 1-1.HOUSING: PA9T,BLACK
- 1-2.CONTACTS: C7025 T=0.15
- 1-3.MID PLATE: SUS301 T=0.15
- 1-4.SHELL: SUS304 T=0.30;
- 1-5.GROUND PLATE: SUS304 T=0.2;
- 1-6.MOLDING: LCP,BLACK,UL94 V-0;

2.PLATING SPECIFICATION:

- 2-1.CONTACTS:  
Ni 50u" MIN. UNDER PLATED OVER ALL.  
Au1u" PLATED ON THE FUNCTIONAL AREA OF CONTACT.  
GOLD FLASH PLATED ON SOLDER AREA.
- 2-2.SHELL:  
Ni 30u" MIN. UNDER PLATED OVER ALL.
- 2-3.GROUND PLATE:  
Ni 30u" MIN. UNDER PLATED OVER ALL.

3.MECHANICAL PERFORMANCE,

- 3-1.INSERTION FORCE: 0.5~2.0kgf.
- 3-2.REMOVAL FORCE: 0.8kgf~2.0kgf.
- 3-3.DURABILITY: 10000 CYCLES.

4.ELECTRICAL PERFORMANCE,

- 4-1. CURRENT RATING:5.0A  
VOLTAGE RATING: 5.0V
- 4-2.INSULATION RESISTANCE: 100MΩ MIN.
- 4-3.DIELECTRIC WITHSTAND VOLTAGE,AC 100V FOR 1 MINUTE.
- 4-4.LOW CONTACT RESISTANCE: INITIAL 40mΩ AFTER 50mΩ

5. ENVIRONMENTAL PERFORMANCE:

OPERATING TEMPERATURE: -55°C~+85°C.

6.IR REFLOW:

THE PEAK TEMPERATURE ON THE BOARD SHALL BE MAINTAINED FOR 10 SECONDS AT 260°C.

7.Water Resistance: IPX8

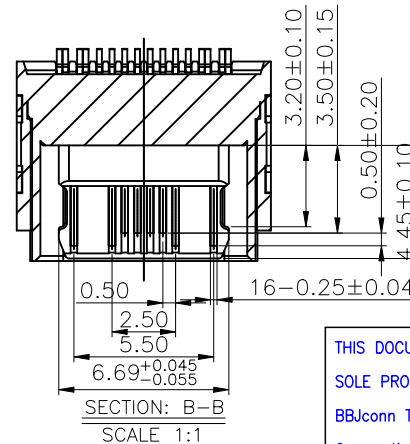
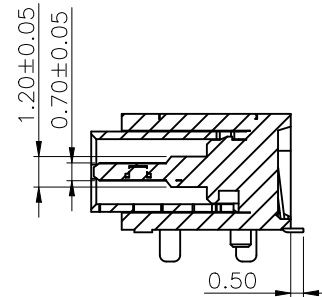
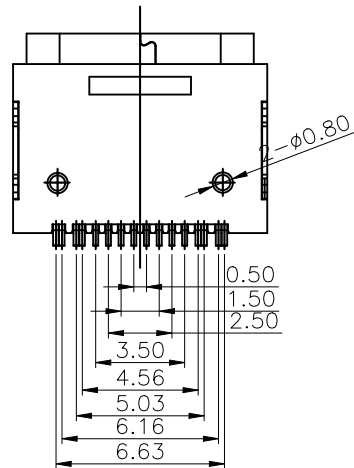
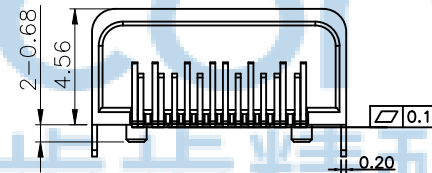
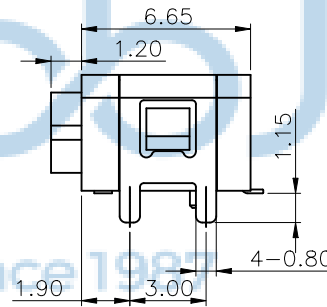
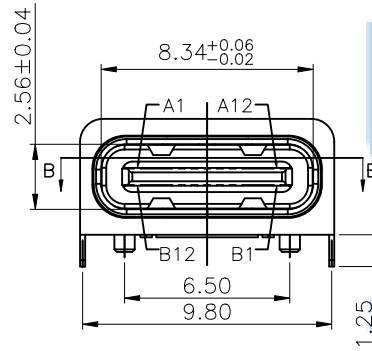
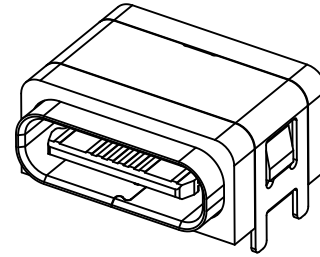
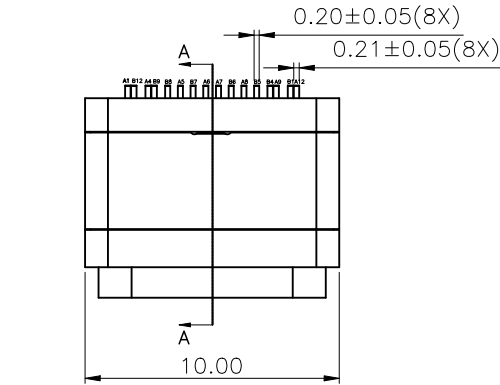

THIS DOCUMENT IS THE  
SOLE PROPERTY OF  
BBJconn Technology Co.,Ltd.  
Corporation AND SHOULD  
NOT BE USED IN WHOLE  
PRIOR WRITTEN PERMISSION.

深圳市步步精科技有限公司 工程 部		NAME: TYPE-C 16P 防水母座 90度 板上四脚插 带柱 端子SMT IPX8 7x1黑色0型防水圈 L=7.85 电流5A 编带	
APPD	JM_Zheng	PJ NO: 126-221-160013-N5G SIZE:A4   DRW NO:	FINISH:SEE NOTES   MAT'L:SEE NOTES SCALE:N/A   REV:A0   UNIT:mm   PAGE:1/3
CHKD	LYX		
PDWG NO: 0366-2	DR	SGF	

.X: ±0.38	.X': ±3'
.XX: ±0.25	.X': ±2'
.XXX: ±0.13	.XX': ±1'

REV	ECN NO	CONTENT	DATE	ENGINEER
AO		INITIAL RELEASE	/	SGF

密封开孔参考尺寸(只供参考),组装外壳时需要打环保润滑油

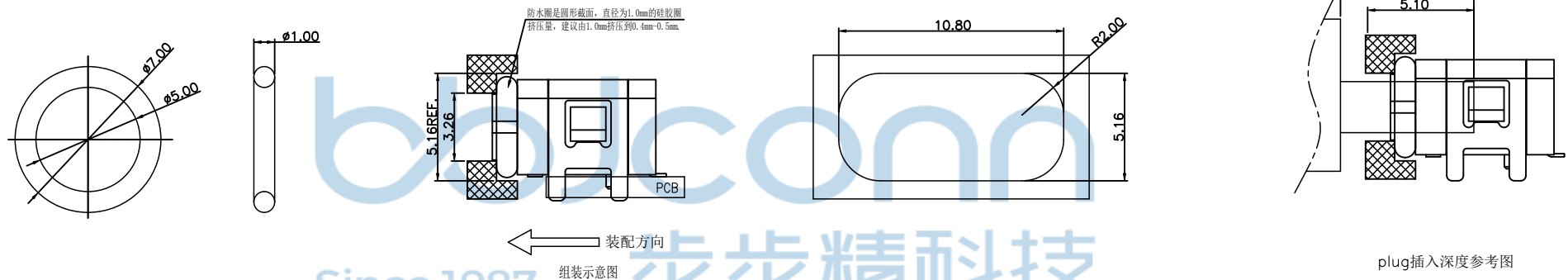

胶圈使用尺寸参考图

PIN ASSIGNMENT:

Pin No.	Signal Name	Pin No.	Signal Name
A1	GND	B12	GND
A2		B11	
A3		B10	
A4	VBUS	B9	VBUS
A5	CC1	B8	SBU2
A6	D+	B7	D-
A7	D-	B6	D+
A8	SBU1	B5	CC2
A9	VBUS	B4	VBUS
A10		B3	
A11		B2	
A12	GND	B1	GND

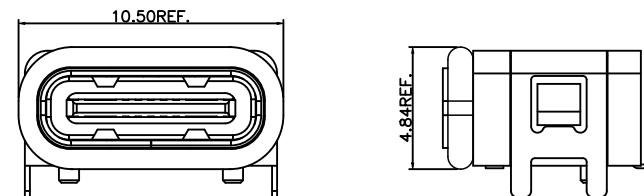
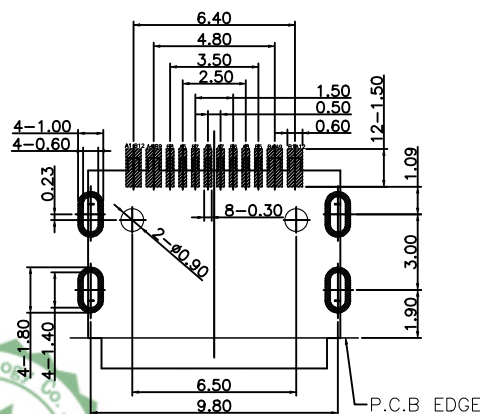

THIS DOCUMENT IS THE SOLE PROPERTY OF BBJconn Technology Co.,Ltd. Corporation AND SHOULD NOT BE USED IN WHOLE PRIOR WRITTEN PERMISSION.		<b>深圳市步步精科技有限公司</b> 工程部	
APPD	JM_Zheng	NAME:	TYPE-C 16P 防水母座 90度 板上四脚插 带柱 端子SMT IPX8 7x1黑色0型防水圈 L=7.85 电流5A 编带
CHKD	LYX	PJ NO:	126-221-160013-N5G
PDWG NO: 0366-2	DR	SGF	SCALE:N/A REV:A0 UNIT:mm PAGE:2/3

REV	ECN NO	CONTENT	DATE	ENGINEER
AO		INITIAL RELEASE	/	SGF

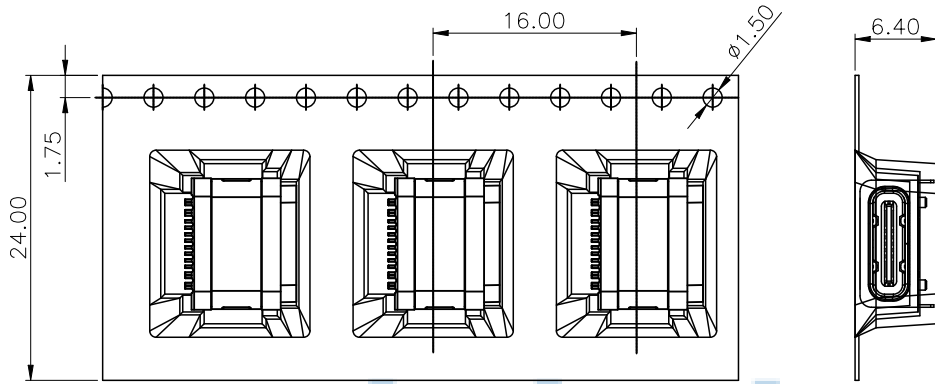

① 产品入载带示意图

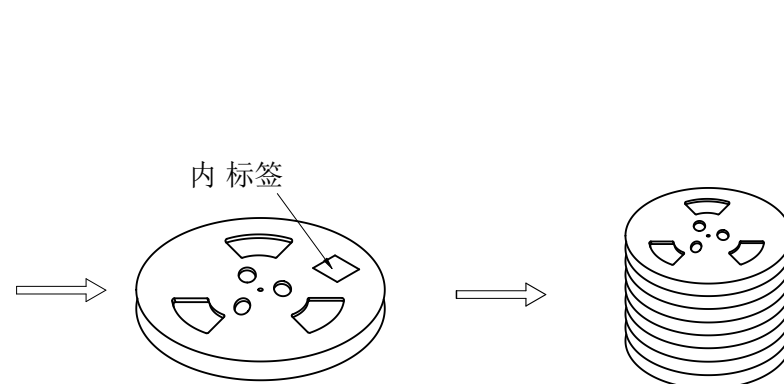

② 卷盘贴标签示意图

③ 产品叠层示意图

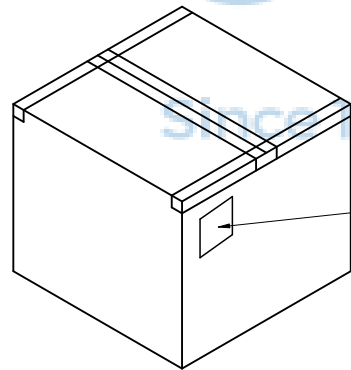

⑤ 外箱封箱示意图

成品标签

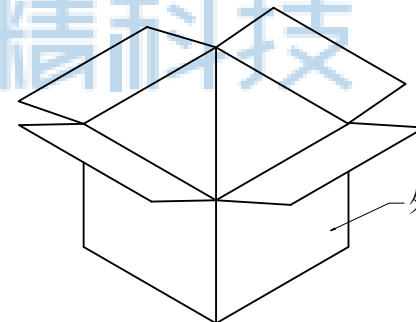

④ 产品入外箱示意图

外箱



	REEL	CARTON
CONNECTOR (PCS)	700	7700

包装说明:

1. 将检验好的成品;对插口朝前放入载带;每卷装700PCS产品;具体如图一所示
2. 将包装好的产品;每盘必需贴上内标签;具体如图二所示
3. 将贴好内标签的产品每7盘叠;具体如图三所示
5. 装好后并封好纸箱及贴好相关标签;具体如图五所示;  
(产品包装的标签,如客户有要求,请按客户要求包装出货)
6. 载带前面留16PCS空格,后面留16PCS空格

THIS DOCUMENT IS THE  
SOLE PROPERTY OF  
BBJconn Technology Co.,Ltd.  
Corporation AND SHOULD  
NOT BE USED IN WHOLE  
PRIOR WRITTEN PERMISSION.  
PDWG NO: 0366-2

深圳市步步精科技有限公司			
.X: ±0.38	X': ±3'	NAME: TYPE-C 16P 防水母座 90度 板上四脚插 带柱 端子SMT	
.XX: ±0.25	.X': ±2'	IPX8 7x1黑色O型防水圈 L=7.85 电流5A 编带	
.XXX: ±0.13	.XX': ±1'	APPD	JM_Zheng
		CHKD	LYX
		DR	SGF
		FINISH:SEE NOTES	MAT'L:SEE NOTES
		SCALE:N/A	REV:AO
		UNIT:mm	PAGE:3/3