

REV	ECN NO	CONTENT	DATE	ENGINEER
A0		INITIAL RELEASE	/	SGF

NOTES:
 1.MECHANICAL:MATING FORCE: 5-20N .
 UNMATING FORCE: 8-20N .
 DURABILITY: 10000 CYCLES MIN.
 2.ELECTRICAL:
 CURRENT: 5.0A MAX
 VOLTAGE: 20V MAX
 WITHSTANDING VOLTAGE: 100V AC
 CONTACT RESISTANCE: 40 mΩ MAX INITIAL;
 50 mΩ MAX AFTER 10000 CYCLES
 3.ENVIRONMENTAL:
 OPERATING TEMPERATURE RANGE -30°C ~ +80°C
 4.Salt Spray:24H

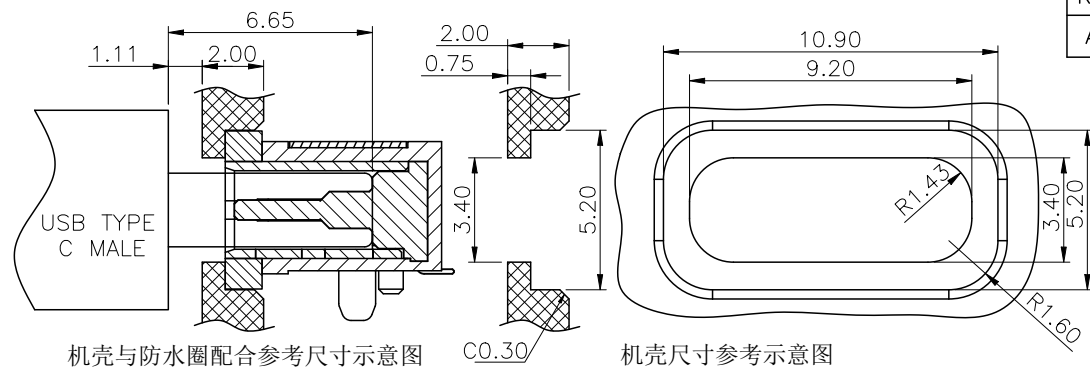
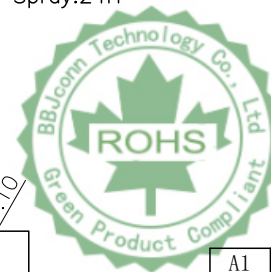

机壳与防水圈配合参考尺寸示意图

机壳尺寸参考示意图

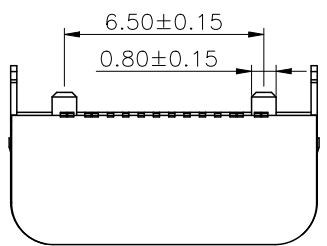

盖子连料缺口的朝向无需区分,
 缺口朝锡脚方向或朝对插口方向都是OK的

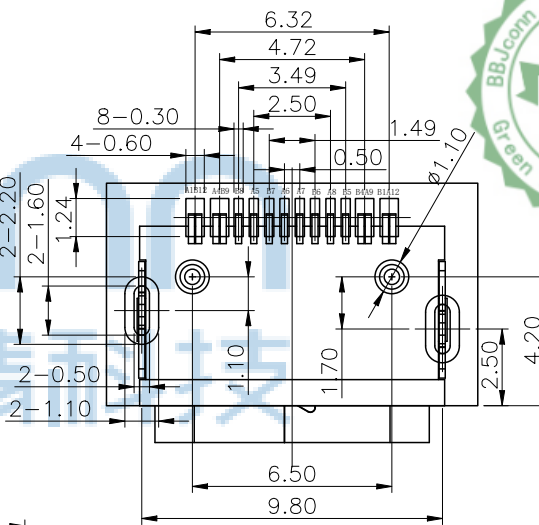
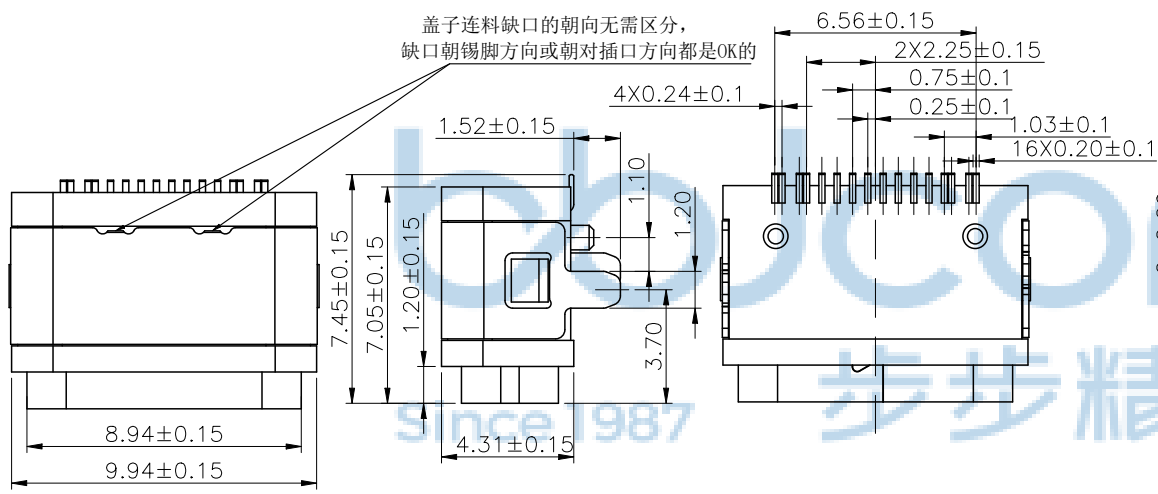

PCB LAYOUT
 TOLERANCESIZE:±0.05

A1	GND	B12	GND
A2		B11	
A3		B10	
A4	VBUS	B9	VBUS
A5	CC1	B8	SBU2
A6	DP1	B7	DN2
A7	DN1	B6	DP2
A8	SBU1	B5	CC2
A9	VBUS	B4	VBUS
A10		B3	
A11		B2	
A12	GND	B1	GND

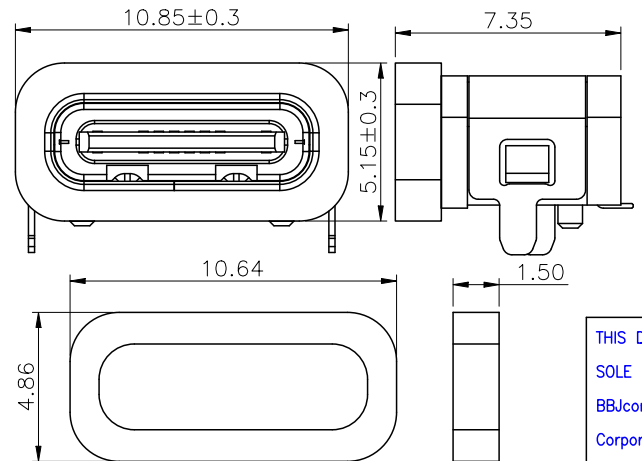
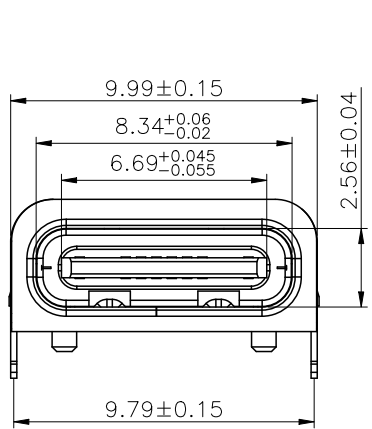

带防水圈示意图



序号	零件名称	规格
01	上盖	SUS 301亮镍50u".48H.
02	中夹片	SUS 301
03	壳子	SHELL SUS 201 亮镍50u".48H.
04	主体	Molding LCP 黑色 C7025 镀金G/F"

THIS DOCUMENT IS THE SOLE PROPERTY OF BBJconn Technology Co.,Ltd. Corporation AND SHOULD NOT BE USED IN WHOLE PRIOR WRITTEN PERMISSION. PDWG NO: 0366-2

深圳市步步精科技有限公司
 工程管理部

NAME:TYPE-C 16P 防水母座 板上两脚插 端子SMT 带中夹片 带柱 L=7.05 IPX6 带防水圈 编带

APPD JM_Zheng
 CHKD LYX
 DR SGF

FINISH:SEE NOTES
 SCALE:N/A
 REV:A0
 UNIT:mm
 PAGE:1/2

PJ NO: 126-221-160015-N5G
 SIZE:A4
 DRW NO:
 MAT'L:SEE NOTES

包装示意图:

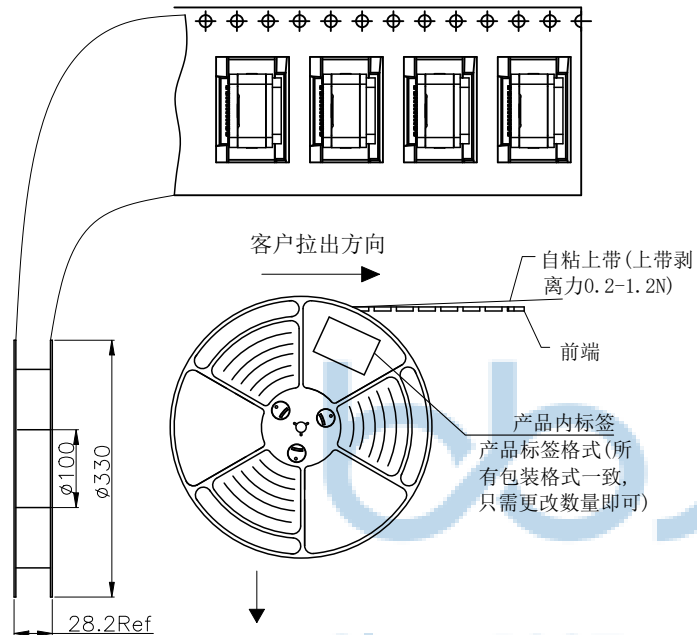
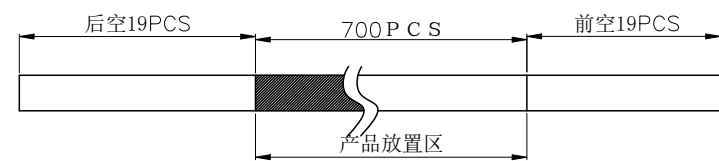

备注:

1. 把上下载带送入载带机进行调整, 然后将产品按照指定的方式摆入下载带中, 开动卷带机进行卷装 (每卷包700PCS), 卷装完成后需用上带缠绕最少20CM;
2. 在卷装OK的每卷盘面的指定位置上贴上物料和RoHS标签装入纸箱内; 每箱装10盘
3. 纸箱用封箱带将其封好, 胶带要求工字型, 不可遮住标签;
4. 如果客户对包装标签另有要求, 请按客户要求作业; 有未满足之零数箱需用缓冲材料填充;
5. 上载带剥离力: 0.2-1.2N. ;

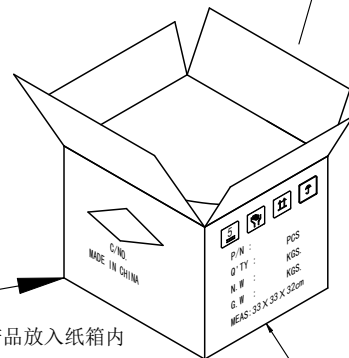
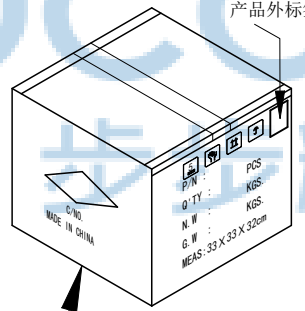

纸箱规格:
34.0X34.0X30CM

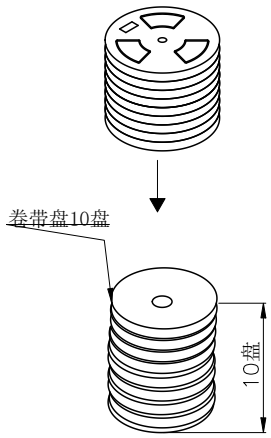

Since 1987



THIS DOCUMENT IS THE SOLE PROPERTY OF BBJconn Technology Co.,Ltd. Corporation AND SHOULD NOT BE USED IN WHOLE PRIOR WRITTEN PERMISSION.		深圳市步步精科技有限公司	
PDWG NO: 0366-2		.X: ± 0.38 .XX: ± 0.25 .XXX: ± 0.13	X': $\pm 3'$ X'': $\pm 2'$.XX': $\pm 1'$
APPD	JM_Zheng	NAME: TYPE-C 16P 防水母座 板上两脚插 端子SMT 带中夹片 带柱 L=7.05 IPX6 带防水圈 编带	
CHKD	LYX	PJ NO: 126-221-160015-N5G	SIZE:A4 DRW NO:
DR	SGF	FINISH:SEE NOTES	MAT'L:SEE NOTES
		SCALE:N/A	REV:A0 UNIT:mm PAGE:2/2