

REV.	ECN NO	CONTENT	DATE	ENGINEER
A0		Initial release	/	TSP

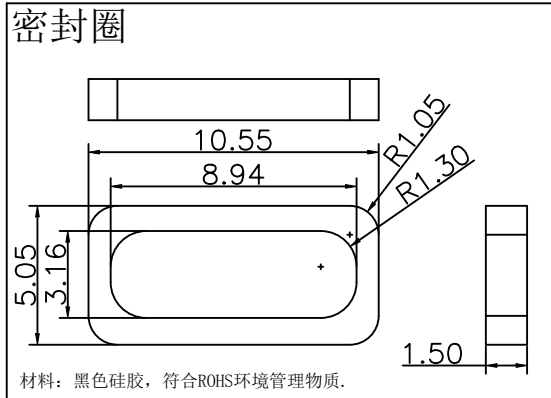

- 备注 (NOTE):
- 电气特性:
    - 接触区: 接触电阻40mΩ Max, 允许10mΩ变化量. 测试条件: 20mv, 100mA下测量.
    - 接触电流: 3A VBUS引脚; 1.25A用于GND引脚; 其他引脚为0.25A.
  - 额定电压: 20V Max.
  - 耐电压: 100 V(AC) for 1 min.
  - 绝缘电阻: 至少100兆欧.
  - 机械性能:
    - 插入力: 5-20N
    - 拔出力: 6-20N
    - 插拔次数: 5000次.
    - 推力: 50N min.
    - 剥离强度: 150N min.
    - 扭曲强度: 0.75Nm
  - 工作环境: -20℃ to +85℃.
  - 尺寸标注事项:
    - 图示有标注“▲”记号者为重点尺寸.
    - 图示未标注公差之尺寸参考公差表.
    - 图示标注“\*”记号之尺寸为对称尺寸.
  - 材料:
    - 塑胶: PA9T 黑色UL94V-0 无卤/LCP E130i黑色UL94V-0 无卤
    - 端子: C2680镀半金雾锡1U”
    - 壳子: SUS304 镀镍24H

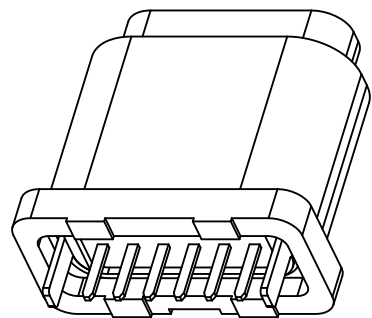
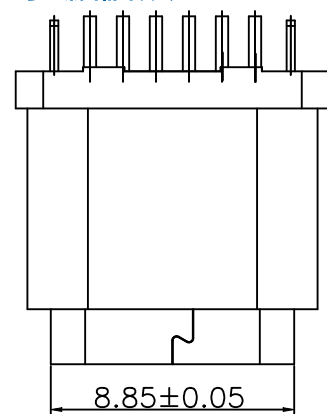
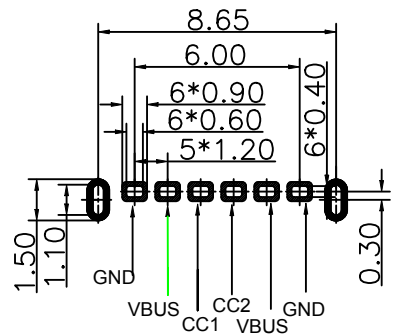
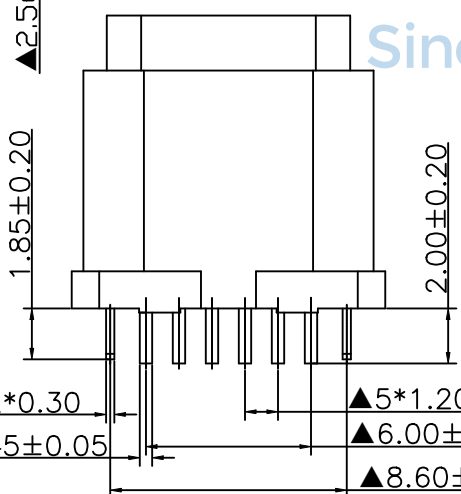
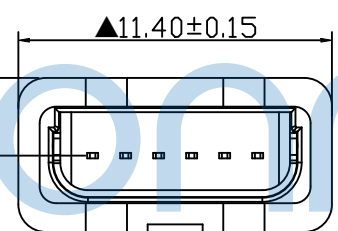
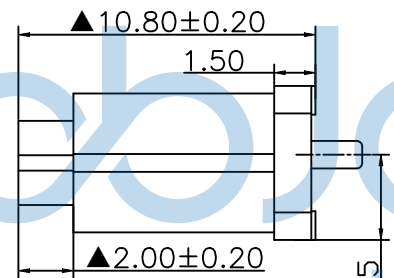
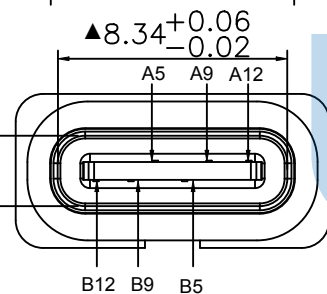

RECOMMENDED P.C.B. LAYOUT  
TOLERANCE UNSPECIFIED ±0.05mm

A5	CC1	B12	GND
A9	VBUS	B9	VBUS
A12	GND	B5	CC2
PIN	SIGNAL NAME	PIN	SIGNAL NAME



THIS DOCUMENT IS THE SOLE PROPERTY OF BBJconn Technology Co., Ltd. Corporation AND SHOULD NOT BE USED IN WHOLE OR IN PART WITHOUT PRIOR WRITTEN PERMISSION.		<b>深圳市步步精科技有限公司</b>	
PDWG.NO: 0366-2	DR. TSP	NAME: TYPE-C 6P 防水母座 直立式 两脚插 端子DIP H=10.80 端子脚长2.0 IPX7 编带	PJ. NO.: 126-225-060003-N5G SIZE: A4 DRW NO.:
.X: ±0.38 .XX: ±0.25 .XXX: ±0.13 X*: ±3* X*: ±2*		FINISH: SEE NOTES SCALE: N/A	MAT'L.: SEE NOTES REV.: A0 UNIT: mm PAGE: 1/2

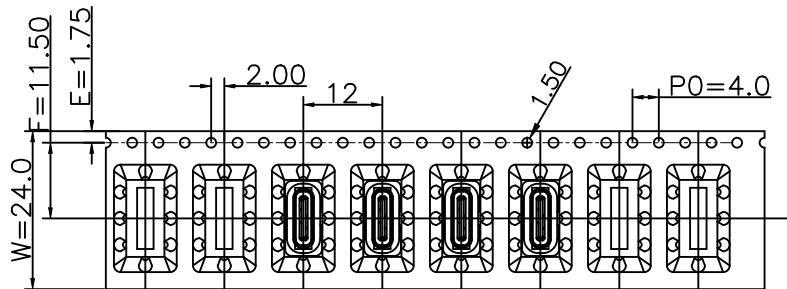

① 产品入载带示意图

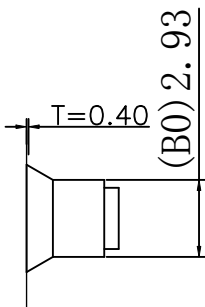

② 卷盘贴标签示意图

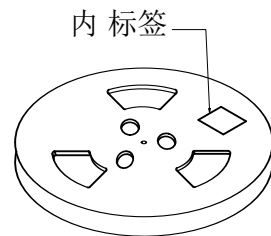

③ 7盘产品叠层示意图

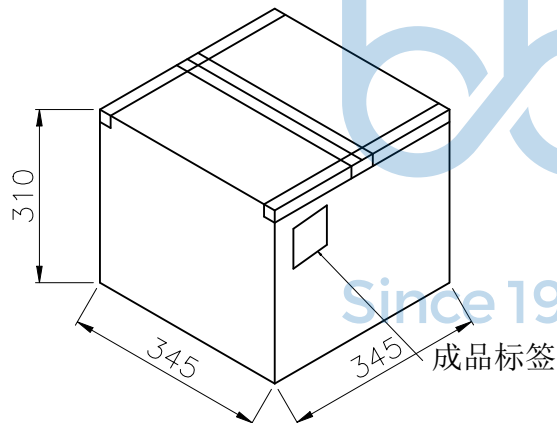

⑤ 外箱封箱示意图

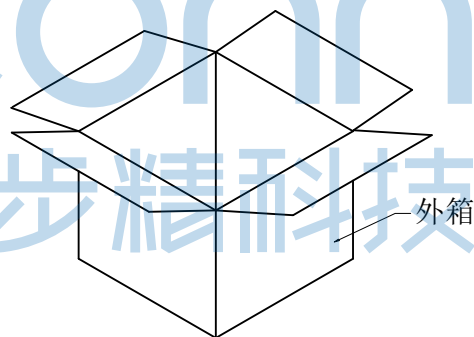

④ 产品入外箱示意图



	REEL	CARTON
CONNECTOR (PCS)	400	2800

**包装说明:**

- 将检验好的成品;对插口朝前放入载带;每卷装400PCS产品;具体如图一所示
- 将包装好的产品;每盘必需贴上内标签;具体如图二所示
- 将贴好内标签的产品每7盘叠;具体如图三所示
- 装好后并封好纸箱及贴好相关标签;具体如图五所示;  
(产品包装的标签,如客户有要求,请按客户要求包装出货)
- 载带前面留12PCS空格,后面留12PCS空格
- COVER与CARRY剥离力:50-125g,速度:300mm/分钟左右,剥离角度:165°-180°



THIS DOCUMENT IS THE SOLE PROPERTY OF		<b>深圳市步步精科技有限公司</b>	
BBJconn Technology Co.,Ltd.		NAME: TYPE-C 6P 防水母座 直立式 两脚插 端子DIP	
Corporation AND SHOULD NOT BE USED IN WHOLE OR IN PART WITHOUT PRIOR WRITTEN PERMISSION.		H=10.80 端子脚长2.0 IPX7 编带	
APPD.	JM_Zheng	PJ. NO.: 126-225-060003-N5G	
CHKD.	LYX	SIZE: A4 DRW NO.:	
DR.	TSP	FINISH: SEE NOTES MAT'L.: SEE NOTES	
PDWG.NO:	0366-2	SCALE: N/A	REV.: A0 UNIT: mm PAGE: 2/2