

REV.	ECN NO	CONTENT	DATE	ENGINEER
A0		Initial release	/	TSP

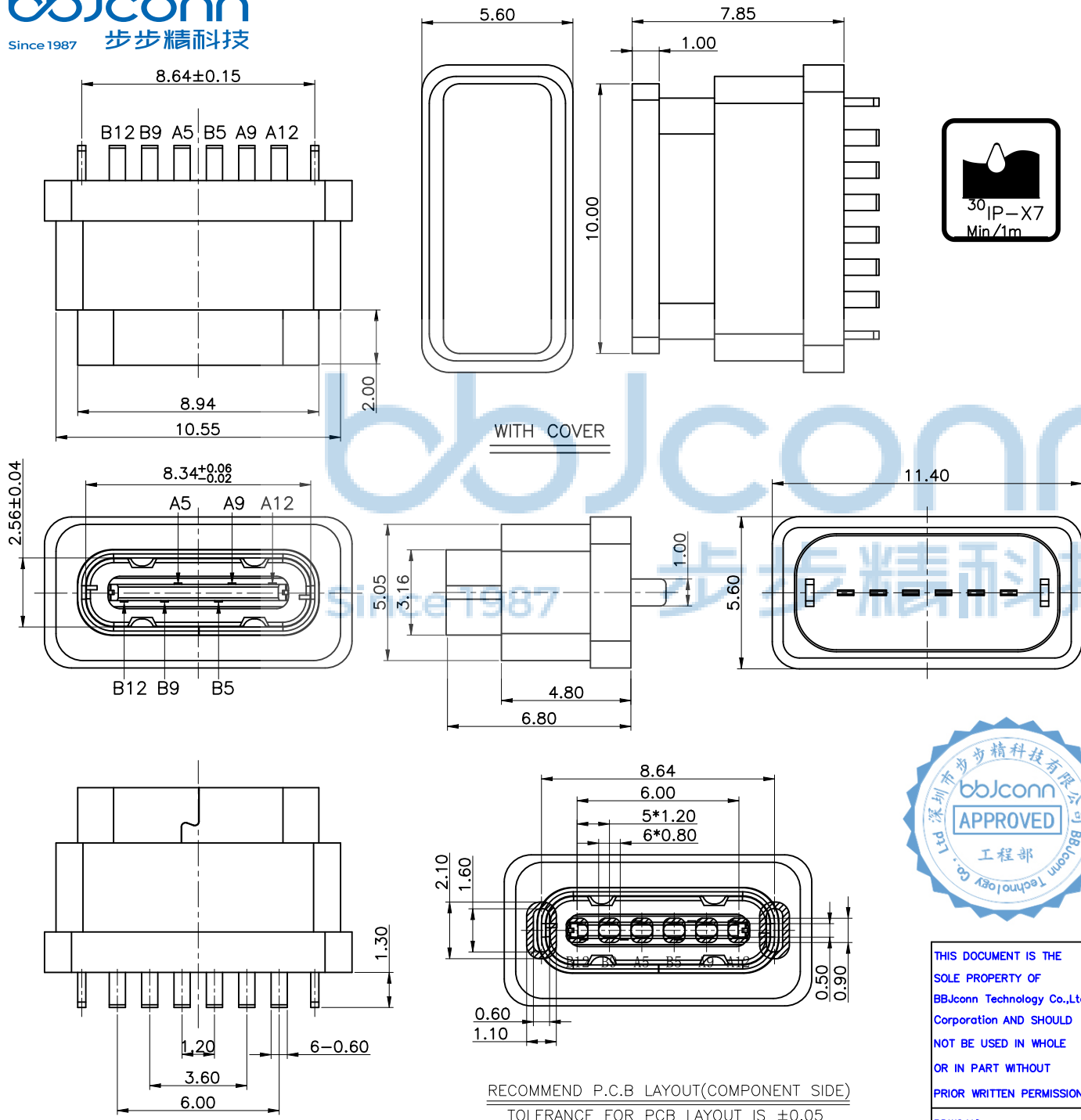

NOTE:

- MATERIAL SPECIFICATION:**
 - HOUSING: HIGH TEMPERATURE RESISTANT PLASTIC(LCP), UL94 V-0.
 - CONTACTS: COPPER ALLOY(C2680)
 - MID PLATE: STAINLESS STEEL(SUS301)
 - SHELL: STAINLESS STEEL(SUS304)
- PLATING SPECIFICATION:**
 - CONTACTS:
 - Ni 50µ" MIN. UNDER PLATED OVER ALL.
 - Au 1µ" ON THE FUNCTIONAL AREA OF CONTACT.
 - MATTE Sn ON THE SOLDER AREA OF CONTACT.
 - FRONT SHELL:
 - Ni 30µ" MIN. UNDER PLATED OVER ALL.
 - MID PLATE:
 - CLEAR ONLY.
- MECHANICAL PERFORMANCE:**
 - INSERTION FORCE: 0.5~2.0kgf.
 - REMOVAL FORCE: 0.8kgf~2.0kgf.
 - DURABILITY: 10000 CYCLES.
- ELECTRICAL PERFORMANCE,**
 - CURRENT RATING: 3.0A
VOLTAGE RATING: 5.0V
 - LLCR:
 - VBUS & GND PINS AND OTHER PINS: 40m /PIN MAX.
 - SHIELD: 50m /MAX.
 - LLCR MAX. CHANGE OF ALL PINS: 10m .
 - INSULATION RESISTANCE: 100M MIN
 - DIELECTRIC WITHSTAND VOLTAGE, AC 100V FOR 1 MINUTE.
- ENVIRONMENTAL PERFORMANCE:**
 - OPERATING TEMPERATURE: -25°C~+85°C.
- IR REFLOW:**
 - THE PEAK TEMPERATURE ON THE BOARD SHALL BE MAINTAINED FOR 10 SECONDS AT 260°C.

USB TYPE C PIN ASSIGNMENTS

PIN NUMBER	SIGNAL NAME	PIN NUMBER	SIGNAL NAME
		B12	GND
		B9	VBUS
A5	CC1		
		B5	CC2
A9	VBUS		
A12	GND		

THIS DOCUMENT IS THE SOLE PROPERTY OF BBJconn Technology Co., Ltd. Corporation AND SHOULD NOT BE USED IN WHOLE OR IN PART WITHOUT PRIOR WRITTEN PERMISSION. PDWG.NO: 0338-1

深圳市步步精科技有限公司
APPROVED
工程 部

NAME: TYPE-C 6P 防水母座 直立式 DIP 两脚插 H=6.80 IPX7 不带方形防水圈 内模LCP 外模PA9T 扁带

APPD. JM_Zheng
CHKD. LYX
DR. TSP

PJ. NO.: 126-225-060003-J8G
SIZE: A4 | DRW NO.:
FINISH: SEE NOTES | MAT'L.: SEE NOTES
SCALE: N/A | REV.: A0 | UNIT: mm | PAGE: 1/2

RECOMMEND P.C.B LAYOUT(COMPONENT SIDE)
TOLERANCE FOR PCB LAYOUT IS ±0.05



REV.	ECN NO.	CONTENT	DATE	ENGINEER
A0		Initial release	/	TSP

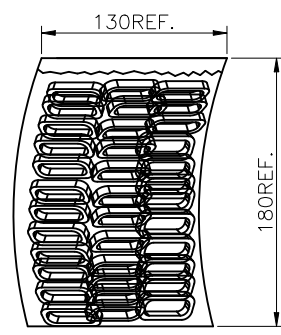
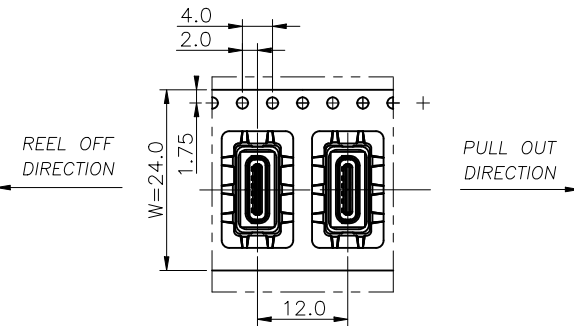
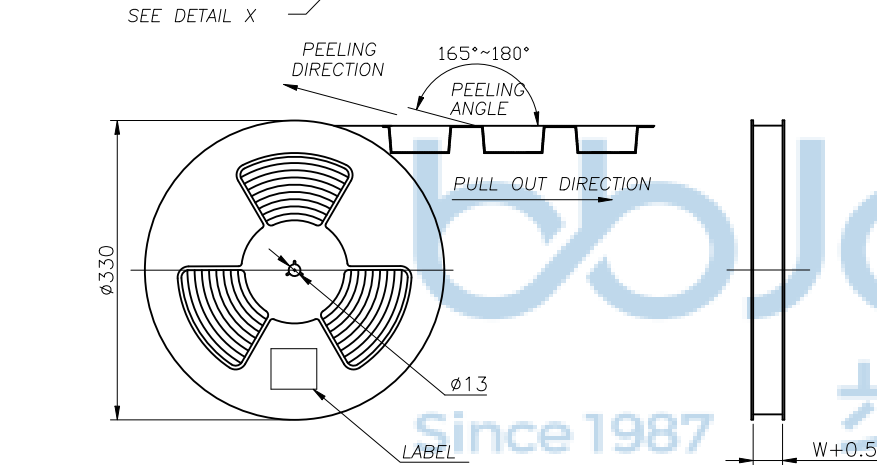
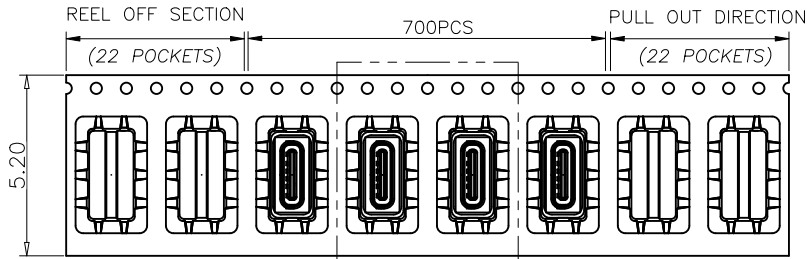

1000PCS/BAG
O-RING

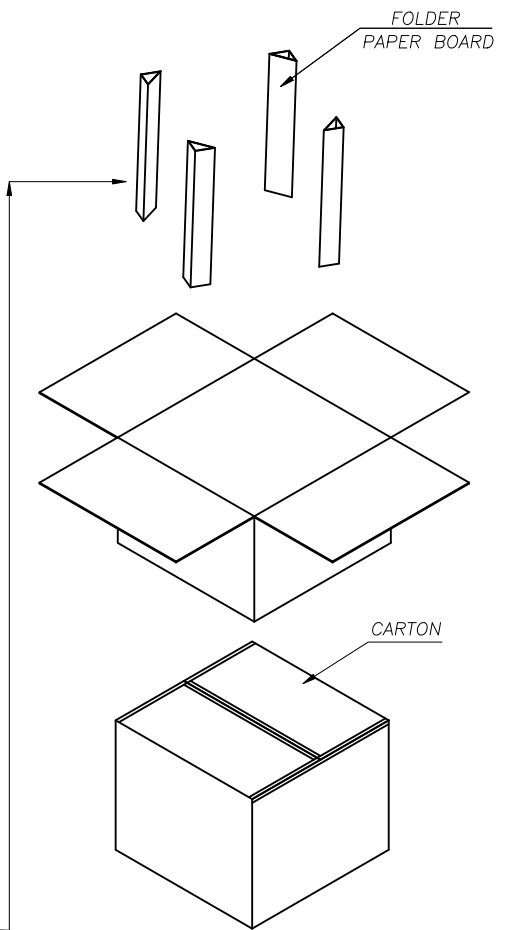
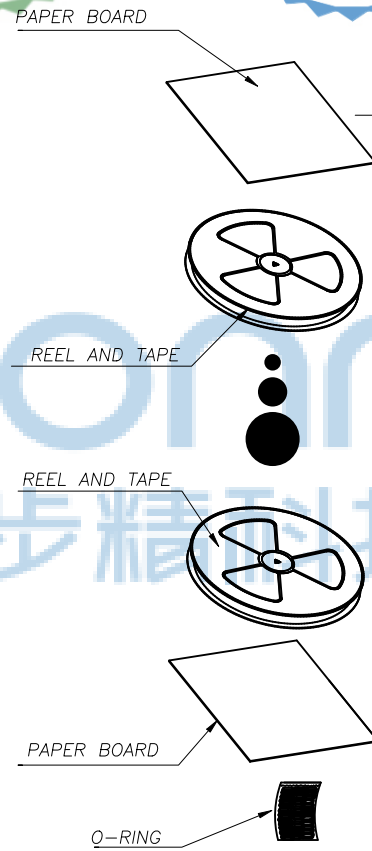

	REEL	CARTON
CONNECTOR (PCS)	700	7000

THIS DOCUMENT IS THE SOLE PROPERTY OF BBJconn Technology Co.,Ltd. Corporation AND SHOULD NOT BE USED IN WHOLE OR IN PART WITHOUT PRIOR WRITTEN PERMISSION.
PDWG.NO: 0338-1

深圳市步步精科技有限公司

.X: ±0.38 .XX: ±0.25 .XXX: ±0.13	X': ±3" .X': ±2" .XX': ±1"	NAME: TYPE-C 6P 防水母座 直立式 DIP 两脚插 H=6.80 IPX7 不带方形防水圈 内模LCP 外模PA9T 编带
APPD. JM_Zheng	CHKD. LYX	PJ. NO.: 126-225-060003-J8G
DR. TSP		SIZE: A4 DRW NO.:
		FINISH: SEE NOTES MAT'L: SEE NOTES
		SCALE: N/A REV.: A0 UNIT: mm PAGE: 2/2